

# EMP30P06D



PIM+

## EMP Features:

### ■ Power Module:

- NPT IGBTs 30A, 600V
- 10us Short Circuit capability
  - Square RBSOA
  - Low  $V_{ce(on)}$  (2.05Vtyp @ 30A, 25°C)
  - Positive  $V_{ce(on)}$  temperature coefficient
- Gen III HexFred Technology
  - Low diode  $V_F$  (1.34Vtyp @ 30A, 25°C)
  - Soft reverse recovery
- 5mΩ sensing resistors on all phase outputs and DCbus minus rail
  - Thermal coefficient < 50ppm/°C

## Description

The EMP30P06D is a Power Integrated Module for Motor Driver applications with embedded sensing resistors on all three-phase output currents.

Each sensing resistor's head is directly bonded to an external pin to reduce parasitic effects and achieve high accuracy on feedback voltages. Since their thermal coefficient is very low, no value compensation is required across the complete operating temperature range.

The device comes in the EMP™ package, fully compatible in length, width and height with EconoPack 2 outline.

## Package:



EMP – Bridge Brake inverter (EconoPack 2 outline compatible)

## Power Module schematic:

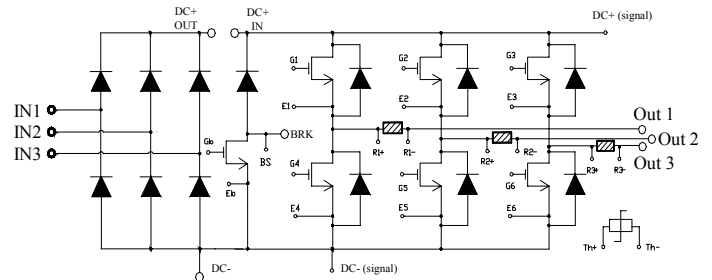

Three phase bridge brake inverter with current sensing resistors on all output phases and thermistor

## Power module frame pins mapping

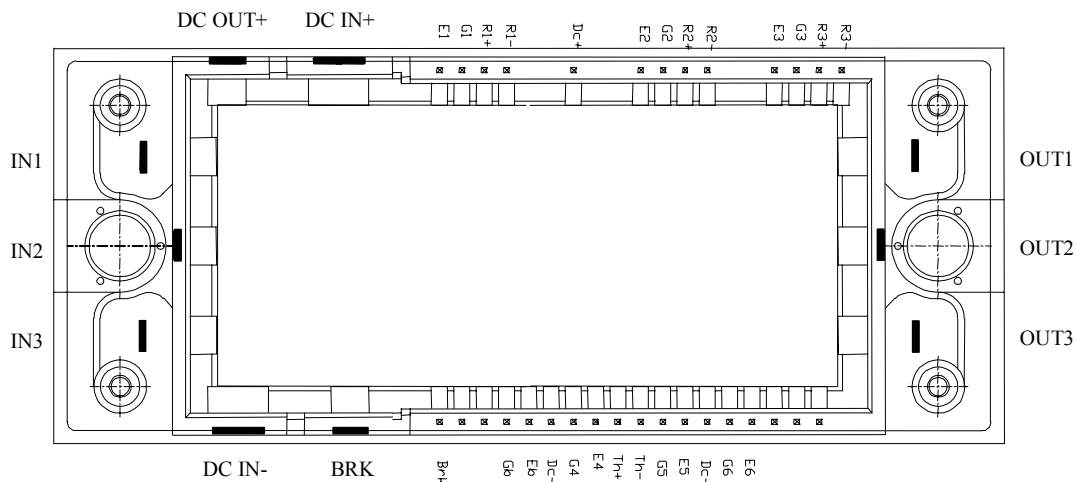

## Pins mapping

Symbol	Lead Description
IN1/2/3	Diode Bridge power input pins
DC OUT+	DC Bus plus power output pin
DC IN+	DC Bus plus power input pin
DC IN-	DC Bus minus power input pin
DC +	DC Bus plus signal connection (Kelvin point)
DC -	DC Bus minus signal connections (Kelvin points)
BRK	Brake power output pin
Brk	Brake signal connection (Kelvin point)
Th +	Thermal sensor positive input
Th -	Thermal sensor negative input
G1/2/3	Gate connections for high side IGBTs
E1/2/3	Emitter connections for high side IGBTs (Kelvin points)
Gb	Gate connection for brake IGBT (Kelvin point)
Eb	Emitter connection for brake IGBT (Kelvin point)
R1/2/3 +	Output current sensing resistor positive input (IGBTs emitters 1/2/3 side, Kelvin points)
R1/2/3 -	Output current sensing resistor negative input (Motor side, Kelvin points)
G4/5/6	Gate connections for low side IGBTs
E4/5/6	Emitter connections for low side IGBTs (Kelvin points)
OUT1/2/3	Three phase power output pins

## General Description

The EMP module contains six IGBTs and HexFred Diodes in a standard inverter configuration. IGBTs used are the new NPT 600V-30A (current rating measured at 80C°), generation V from International Rectifier; the HexFred diodes have been designed specifically as pair elements for these power transistors. Thanks to the new design and technological realization, these devices do not need any negative gate voltage for their complete turn off; moreover the tail effect is also substantially reduced compared to competitive devices of the same family. This feature tremendously simplifies the gate driving stage. Another innovative feature in this type of power modules is the presence of sensing resistors in the three output phases, for precise motor current sensing and short circuit protections, as well as another resistor of the same value in the DC bus minus line, needed only for device protections purposes. A complete schematic of the EMP module is shown on page 1 where all sensing resistors have been clearly evidenced, a thermal sensor with negative temperature coefficient is also embedded in the device structure.

The package chosen is mechanically compatible with the well known EconoPack outline, Also the height of the plastic cylindrical nuts for the external PCB positioned on

its top is the same as the EconoPack II, so that, with the only re-layout of the main motherboard, this module can fit into the same mechanical fixings of the standard EconoPack II package thus speeding up the device evaluation in an already existing driver. An important feature of this new device is the presence of Kelvin connections for all feedback and command signals between the board and the module with the advantage of having all emitter and resistor sensing independent from the main power path. The final benefit is that all low power signal from/to the controlling board are unaffected by parasitic inductances or resistances inevitably present in the module power layout. The new package outline is shown on bottom of page 1. Notice that because of high current spikes on those inputs the DC bus power pins are doubled in size compared to the other power pins. Module technology uses the standard and well known DBC (Direct Bondable Copper): over a thick Copper base an alumina (Al<sub>2</sub>O<sub>3</sub>) substrate with a 300µm copper foil on both side is placed and IGBTs and Diodes dies are directly soldered, through screen printing process. These dies are then bonded with a 15 mils aluminum wire for power and signal connections. All components are then completely covered by a silicone gel for mechanical protection and electrical isolation purposes.

### Absolute Maximum Ratings ( $T_C=25^{\circ}\text{C}$ )

Absolute Maximum Ratings indicate sustained limits beyond which damage to the device may occur. All voltage parameters are absolute voltages referenced to  $V_{DC-}$ , all currents are defined positive into any lead. Thermal Resistance and Power Dissipation ratings are measured at still air conditions.

	Symbol	Parameter Definition	Min.	Max.	Units
<b>Inverter and Brake</b>	$V_{DC}$	DC Bus Voltage	0	500	V
	$V_{CES}$	Collector Emitter Voltage	0	600	
	$I_C @ 100^{\circ}\text{C}$	IGBTs continuous collector current ( $T_C = 100^{\circ}\text{C}$ , fig. 1)		25	A
	$I_C @ 80^{\circ}\text{C}$	IGBTs continuous collector current ( $T_C = 80^{\circ}\text{C}$ , fig 1)		30	
	$I_C @ 25^{\circ}\text{C}$	IGBTs continuous collector current ( $T_C = 25^{\circ}\text{C}$ , fig 1)		45	
	$I_{CM}$	Pulsed Collector Current (Fig. 3, Fig. CT.5)		90	
	$I_F @ 100^{\circ}\text{C}$	Diode Continuous Forward Current ( $T_C = 100^{\circ}\text{C}$ )		25	
	$I_F @ 25^{\circ}\text{C}$	Diode Continuous Forward Current ( $T_C = 25^{\circ}\text{C}$ )		45	
	$I_{FM}$	Diode Maximum Forward Current		90	
	$V_{GE}$	Gate to Emitter Voltage	-20	+20	V
	$P_D @ 25^{\circ}\text{C}$	Power Dissipation (One transistor)		138	W
	$P_D @ 100^{\circ}\text{C}$	Power Dissipation (One transistor, $T_C = 100^{\circ}\text{C}$ )		55	
<b>Bridge</b>	$V_{RRM}$	repetitive peak reverse voltage ( $T_j = 150^{\circ}\text{C}$ )		1400	V
	$V_{RSM}$	non repetitive peak reverse voltage		1500	
	$I_o$	Diode Continuous Forward Current ( $T_C = 100^{\circ}\text{C}$ , $120^{\circ}$ Rect conduction angle)		45	A
	$I_{FSM}$	One-cycle forward. Non-repetitive on state surge current ( $t=10\text{ms}$ , Initial $T_j=150^{\circ}\text{C}$ )	100% $V_{RRM}$ reapplied		
			No voltage reapplied		270
	$I^2t$	Current $I^2t$ for fusing ( $t=10\text{ms}$ , Initial $T_j=150^{\circ}\text{C}$ )	100% $V_{RRM}$ reapplied		253
No voltage reapplied				365	
$I^2\sqrt{t}$	Current $I^2\sqrt{t}$ for fusing ( $t=0.1$ to $10\text{ms}$ , no voltage reapplied, Initial $T_j= 150^{\circ}\text{C}$ )		3650	$\text{A}^2\sqrt{\text{s}}$	
<b>Power Module</b>	MT	Mounting Torque		3.5	Nm
	$T_J$	Operating Junction Temperature	-40	+150	$^{\circ}\text{C}$
	$T_{STG}$	Storage Temperature Range	-40	+125	
	Vc-iso	Isolation Voltage to Base Copper Plate	-2500	+2500	V

### Electrical Characteristics: Inverter and Brake

For proper operation the device should be used within the recommended conditions.

**T<sub>J</sub> = 25°C (unless otherwise specified)**

Symbol	Parameter Definition	Min.	Typ.	Max.	Units	Test Conditions	Fig.
V <sub>(BR)CES</sub>	Collector To Emitter Breakdown Voltage	600			V	V <sub>GE</sub> = 0V, I <sub>C</sub> = 250μA	
ΔV <sub>(BR)CES / ΔT</sub>	Temperature Coeff. of Breakdown Voltage		0.67		V/°C	V <sub>GE</sub> = 0V, I <sub>C</sub> = 1mA (25 - 125 °C)	
V <sub>CE(on)</sub>	Collector To Emitter Saturation Voltage		1.91	2.2	V	I <sub>C</sub> = 25A, V <sub>GE</sub> = 15V	5, 6
			2.46	2.87		I <sub>C</sub> = 45A, V <sub>GE</sub> = 15V	7, 9
			2.19	2.55		I <sub>C</sub> = 25A, V <sub>GE</sub> = 15V, T <sub>J</sub> = 125 °C	10, 11
V <sub>GE(th)</sub>	Gate Threshold Voltage	4	4.46	5	V	V <sub>CE</sub> = V <sub>GE</sub> , I <sub>C</sub> = 250μA	12
ΔV <sub>GE(th) / ΔT<sub>J</sub></sub>	Temp. Coeff. of Threshold Voltage		-10		mV/°C	V <sub>CE</sub> = V <sub>GE</sub> , I <sub>C</sub> = 1mA (25 - 125 °C)	
g <sub>fe</sub>	Forward Transconductance		18		S	V <sub>CE</sub> = 50V, I <sub>C</sub> = 30A	
I <sub>CES</sub>	Zero Gate Voltage Collector Current			250	μA	V <sub>GE</sub> = 0V, V <sub>CE</sub> = 600V	
			368	580		V <sub>GE</sub> = 0V, V <sub>CE</sub> = 600V, T <sub>J</sub> = 125 °C	
				2000		V <sub>GE</sub> = 0V, V <sub>CE</sub> = 600V, T <sub>J</sub> = 150 °C	
V <sub>FM</sub>	Diode Forward Voltage Drop		1.29	1.48	V	I <sub>C</sub> = 25A	8
			1.25	1.5		I <sub>C</sub> = 25A, T <sub>J</sub> = 125 °C	
I <sub>GES</sub>	Gate To Emitter Leakage Current			±100	nA	V <sub>GE</sub> = ±20V	
R1/2/3	Sensing Resistors	4.95	5	5.05	mΩ		

### Electrical Characteristics: Bridge

For proper operation the device should be used within the recommended conditions.

**T<sub>J</sub> = 25°C (unless otherwise specified)**

Symbol	Parameter Definition	Min.	Typ.	Max.	Units	Test Conditions	Fig.
V <sub>FM</sub>	Forward Voltage Drop			1.45	V	t <sub>p</sub> = 400μs, I <sub>pk</sub> = 45A	24
V <sub>F(TO)</sub>	Threshold voltage		0.78		V	T <sub>J</sub> = 125 °C	
I <sub>rm</sub>	Reverse Leakage Current			5	mA	T <sub>J</sub> = 125 °C   V <sub>R</sub> = 1200V	

### Switching Characteristics: Inverter and Brake

For proper operation the device should be used within the recommended conditions.

**T<sub>J</sub> = 25°C (unless otherwise specified)**

Symbol	Parameter Definition	Min	Typ	Max	Units	Test Conditions	Fig.
Q <sub>g</sub>	Total Gate Charge (turn on)		102	153	nC	I <sub>C</sub> = 30A V <sub>CC</sub> = 400V V <sub>GE</sub> = 15V	23 CT1
Q <sub>ge</sub>	Gate – Emitter Charge (turn on)		14	21			
Q <sub>gc</sub>	Gate – Collector Charge (turn on)		44	66			
E <sub>on</sub>	Turn on Switching Loss		0.469	0.779	mJ	I <sub>C</sub> = 30A, V <sub>CC</sub> = 400V, T <sub>J</sub> = 25 °C V <sub>GE</sub> = 15V, R <sub>G</sub> = 10Ω, L = 800μH Tail and Diode Rev. Recovery included	CT4 WF1 WF2
E <sub>off</sub>	Turn off Switching Loss		0.338	0.507			
E <sub>tot</sub>	Total Switching Loss		0.807	1.281			
E <sub>on</sub>	Turn on Switching Loss		0.631	0.946	mJ	I <sub>C</sub> = 30A, V <sub>CC</sub> = 400V, T <sub>J</sub> = 125 °C V <sub>GE</sub> = 15V, R <sub>G</sub> = 10Ω, L = 800μH Tail and Diode Rev. Recovery included	13, 15 CT4 WF1 WF2
E <sub>off</sub>	Turn off Switching Loss		0.604	0.906			
E <sub>tot</sub>	Total Switching Loss		1.235	1.852			
td (on)	Turn on delay time		101	152	ns	I <sub>C</sub> = 30A, V <sub>CC</sub> = 400V, T <sub>J</sub> = 125 °C V <sub>GE</sub> = 15V, R <sub>G</sub> = 10Ω, L = 800μH	14,16 CT4 WF1 WF2
Tr	Rise time		25	38			
td (off)	Turn off delay time		130	195			
Tf	Fall time		105	156			
C <sub>ies</sub>	Input Capacitance		1750		pF	V <sub>CC</sub> = 30V V <sub>GE</sub> = 0V f = 1MHz	22
C <sub>oes</sub>	Output Capacitance		160				
C <sub>res</sub>	Reverse Transfer Capacitance		60				
RBSOA	Reverse Bias Safe Operating Area	FULL SQUARE				T <sub>J</sub> = 150 °C, I <sub>C</sub> = 90A, V <sub>GE</sub> = 15V to 0V V <sub>CC</sub> = 500V, V <sub>P</sub> = 600V, R <sub>G</sub> = 10Ω	4 CT2
SCSOA	Short Circuit Safe Operating Area	10			μs	T <sub>J</sub> = 150 °C, V <sub>GE</sub> = 15V to 0V V <sub>CC</sub> = 360V, V <sub>P</sub> = 600V, R <sub>G</sub> = 10Ω	CT3 WF4
E <sub>REC</sub>	Diode reverse recovery energy		925	1165	μJ	T <sub>J</sub> = 125 °C	17,18 19,20 21 CT4 WF3
T <sub>rr</sub>	Diode reverse recovery time		77		ns	I <sub>F</sub> = 30A, V <sub>CC</sub> = 400V,	
I <sub>rr</sub>	Peak reverse recovery current		62	93	A	V <sub>GE</sub> = 15V, R <sub>G</sub> = 10Ω, L = 800μH	
R <sub>thJ-C,T</sub>	Each IGBT to copper plate thermal resistance		0.806	0.9	°C/W	See also fig. 25 and 26	
R <sub>thJ-C,D</sub>	Each Diode to copper plate thermal resistance		1.06	1.22	°C/W		
R <sub>thC-H</sub>	Module copper plate to heat sink thermal resistance. Silicon grease applied = 0.1mm		0.03		°C/W		
P <sub>diss</sub>	Total Dissipated Power		23		W	I <sub>C</sub> = 3.3A, V <sub>DC</sub> = 300V, f <sub>sw</sub> = 8kHz, T <sub>C</sub> = 55 °C	PD1
			40			I <sub>C</sub> = 6A, V <sub>DC</sub> = 300V, f <sub>sw</sub> = 8kHz, T <sub>C</sub> = 55 °C	PD2
			61			I <sub>C</sub> = 6A, V <sub>DC</sub> = 300V, f <sub>sw</sub> = 16kHz T <sub>C</sub> = 55 °C,	PD3
			95			I <sub>C</sub> = 14A, V <sub>DC</sub> = 300V, f <sub>sw</sub> = 4kHz, T <sub>C</sub> = 55°C	

Fig. 1 – Maximum DC collector Current vs. case temperature

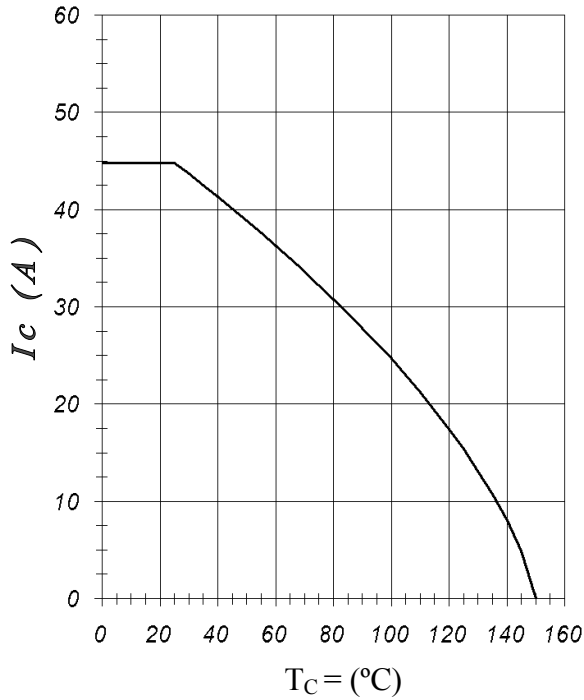

Fig. 2 – Power Dissipation vs. Case Temperature

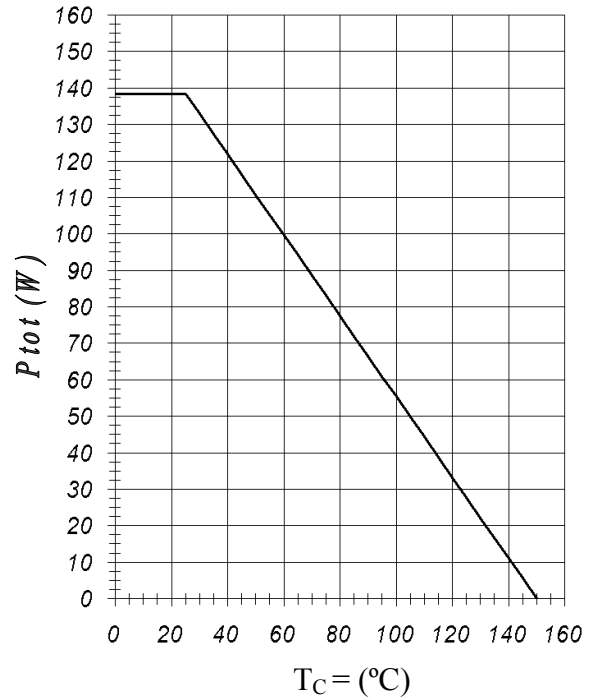

Fig. 3 – Forward SOA  
 $T_C = 25^\circ\text{C}; T_j \leq 150^\circ\text{C}$

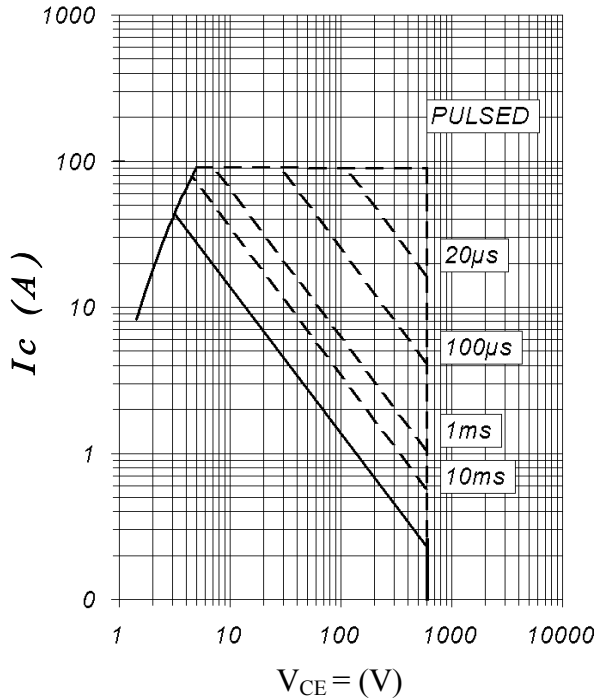

Fig. 4 – Reverse Bias SOA  
 $T_j = 150^\circ\text{C}, V_{GE} = 15\text{V}$

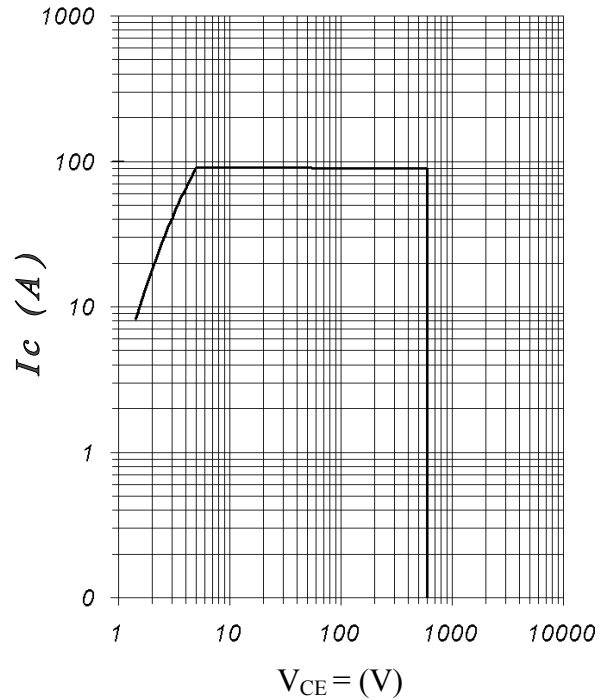

Fig. 5 – Typical IGBT Output Characteristics  
 $T_j = -40^{\circ}\text{C}$ ;  $t_p = 500\mu\text{s}$

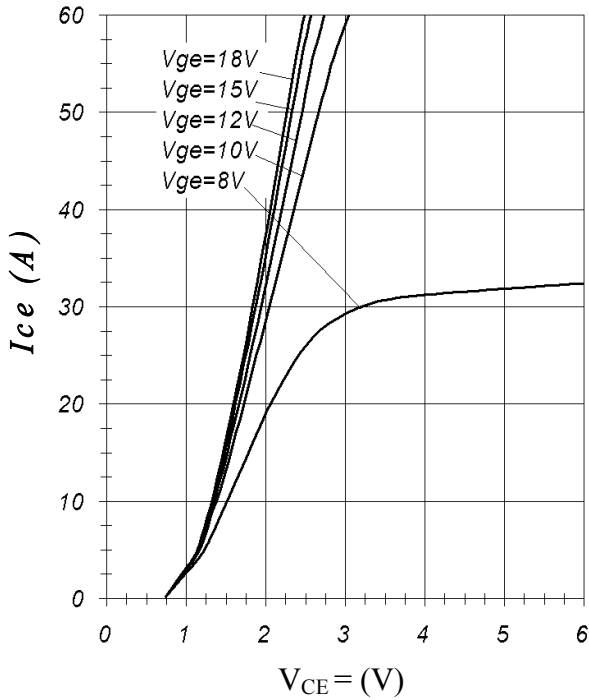

Fig. 6 – Typical IGBT Output characteristics  
 $T_j = 25^{\circ}\text{C}$ ;  $t_p = 500\mu\text{s}$

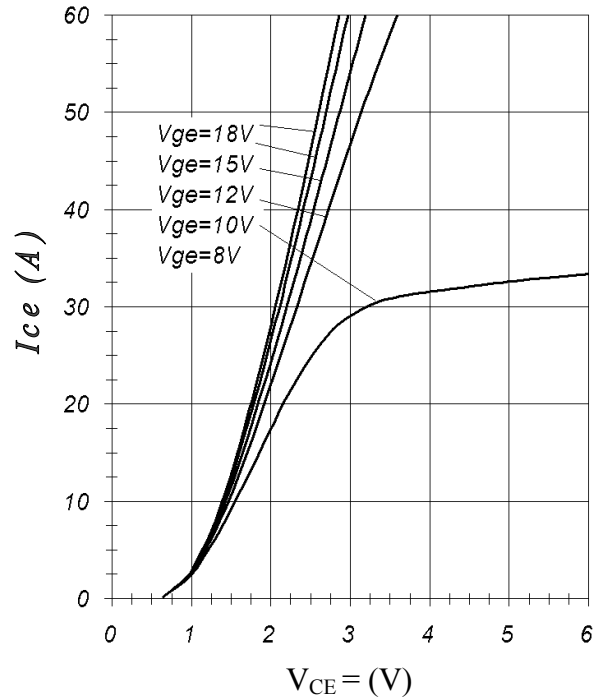

Fig. 7 – Typical IGBT Output Characteristics  
 $T_j = 125^{\circ}\text{C}$ ;  $t_p = 500\mu\text{s}$

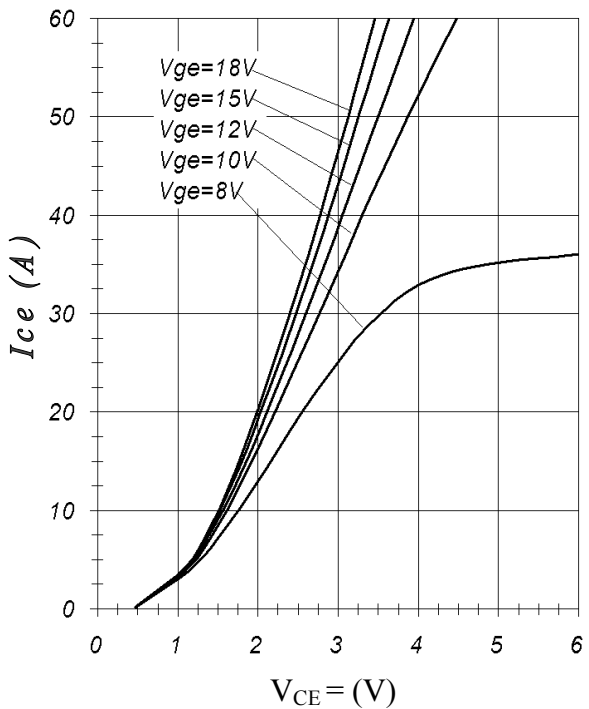

Fig. 8 – Typical Diode Forward Characteristics  
 $t_p = 500\mu\text{s}$

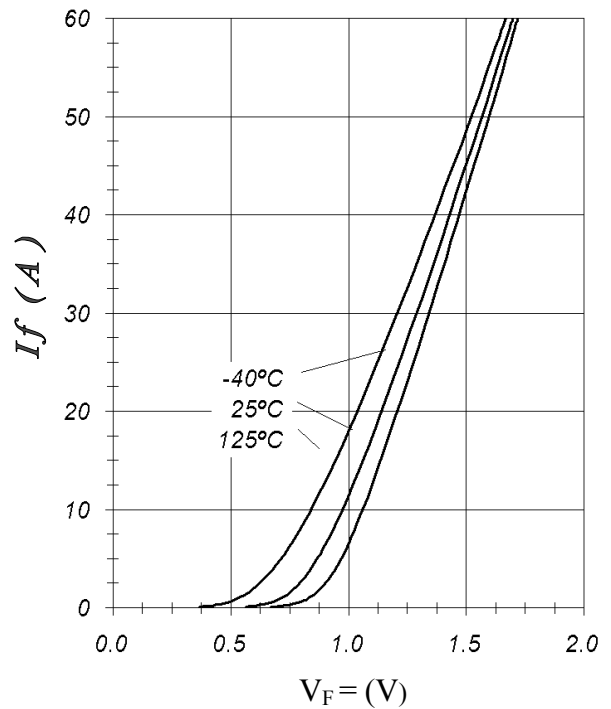

Fig. 9 – Typical  $V_{CE}$  vs.  $V_{GE}$   
 $T_j = -40^\circ\text{C}$

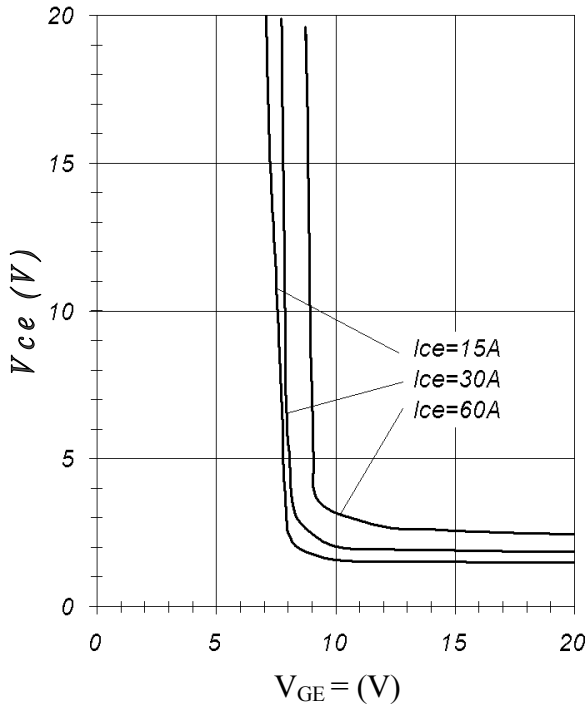

Fig. 10 – Typical  $V_{CE}$  vs.  $V_{GE}$   
 $T_j = 25^\circ\text{C}$

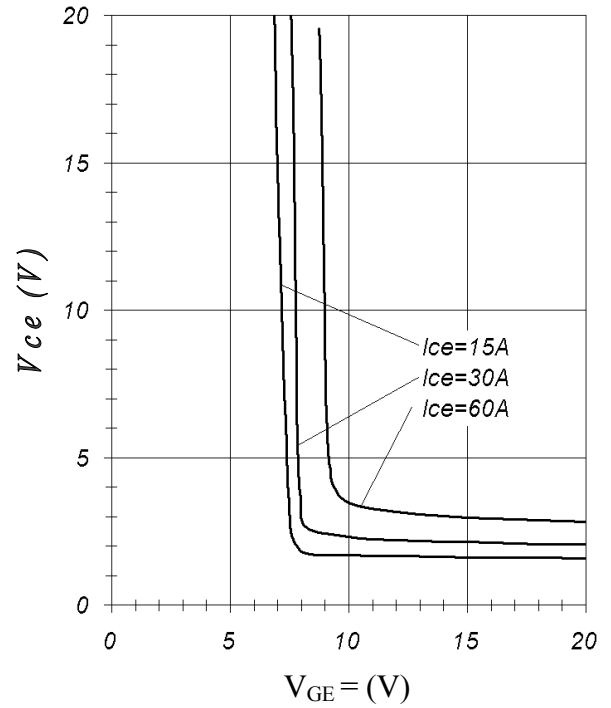

Fig. 11 – Typical  $V_{CE}$  vs.  $V_{GE}$   
 $T_j = 125^\circ\text{C}$

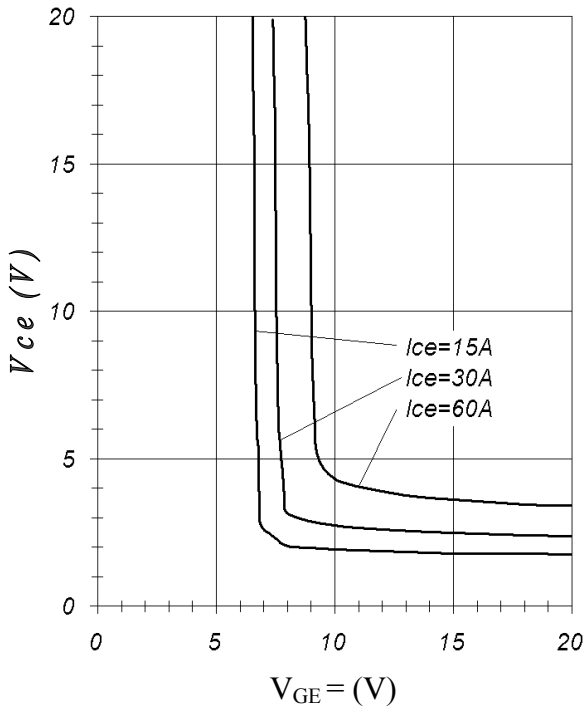

Fig. 12 – Typical Transfer Characteristics  
 $V_{CE} = 20\text{V}$ ;  $t_p = 20\mu\text{s}$

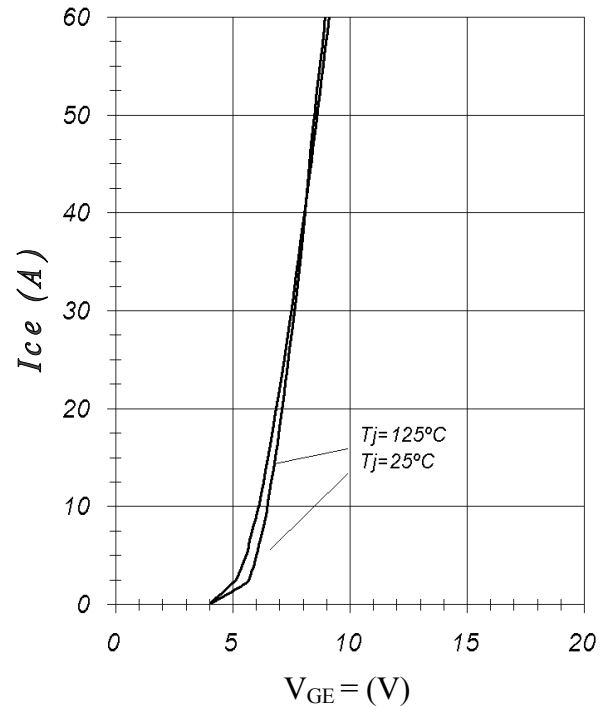



Fig. 13 – Typical Energy Loss vs.  $I_C$   
 $T_j = 125^\circ\text{C}$ ;  $L = 800\mu\text{H}$ ;  $V_{CE} = 400\text{V}$ ;  
 $R_g = 10\Omega$ ;  $V_{GE} = 15\text{V}$

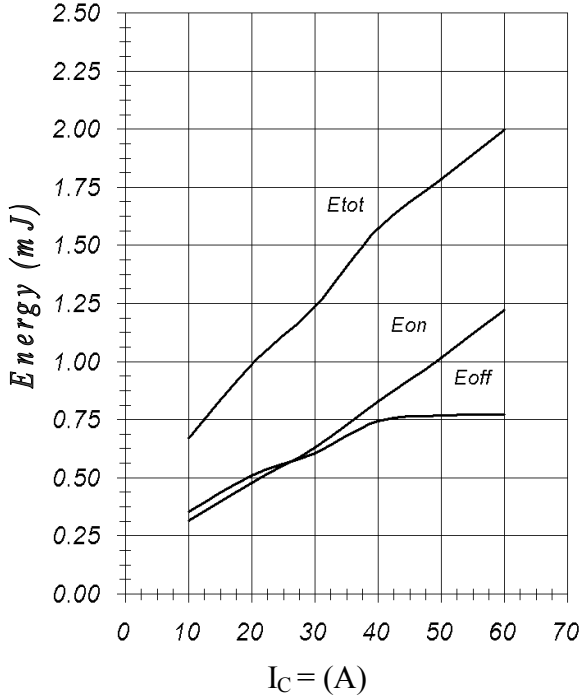

Fig. 14 – Typical Switching Time vs.  $I_C$   
 $T_j = 125^\circ\text{C}$ ;  $L = 800\mu\text{H}$ ;  $V_{CE} = 400\text{V}$ ;  
 $R_g = 10\Omega$ ;  $V_{GE} = 15\text{V}$

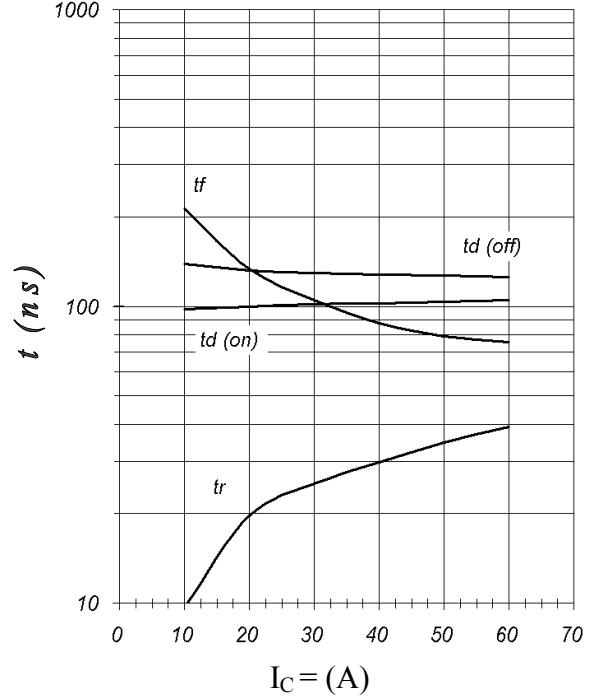

Fig. 15 – Typical Energy Loss vs.  $R_g$   
 $T_j = 125^\circ\text{C}$ ;  $L = 800\mu\text{H}$ ;  $V_{CE} = 400\text{V}$ ;  
 $I_{CE} = 30\text{A}$ ;  $V_{GE} = 15\text{V}$

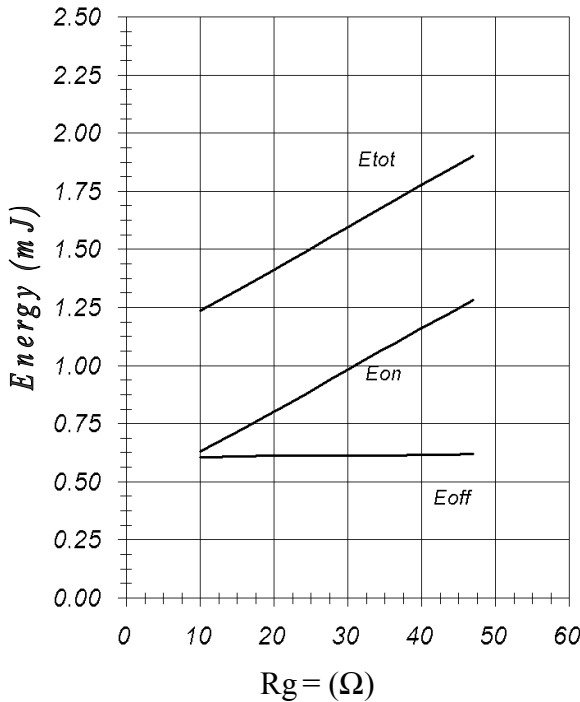

Fig. 16 – Typical Switching Time vs.  $R_g$   
 $T_j = 125^\circ\text{C}$ ;  $L = 800\mu\text{H}$ ;  $V_{CE} = 400\text{V}$ ;  
 $I_{CE} = 30\text{A}$ ;  $V_{GE} = 15\text{V}$

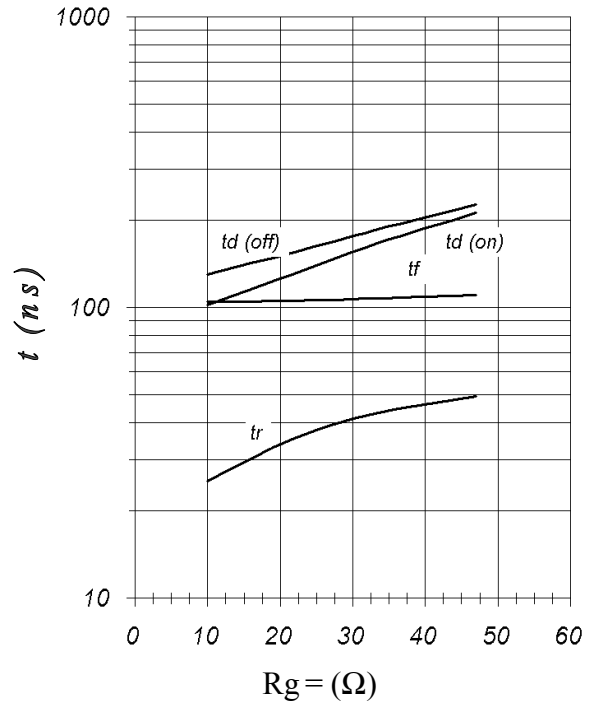

Fig. 17 – Typical Diode  $I_{RR}$  vs.  $I_F$   
 $T_j = 125^\circ\text{C}$

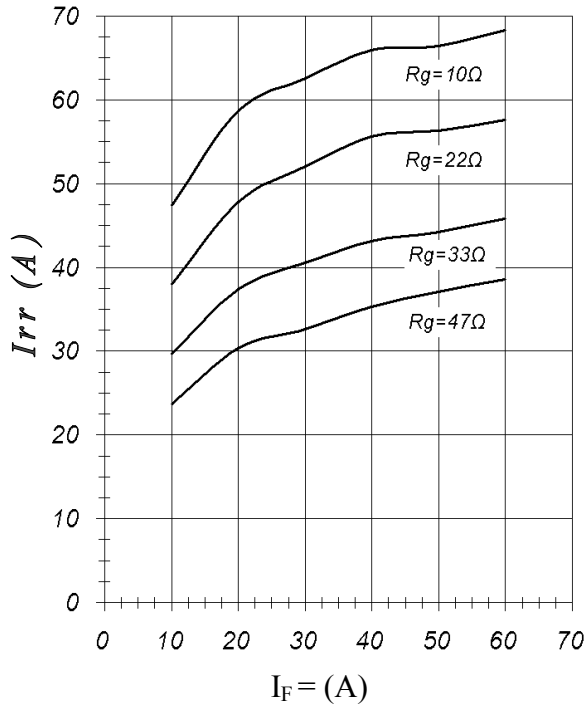

Fig. 18 – Typical Diode  $I_{RR}$  vs.  $R_g$   
 $I_F = 30\text{A}; T_j = 125^\circ\text{C}$

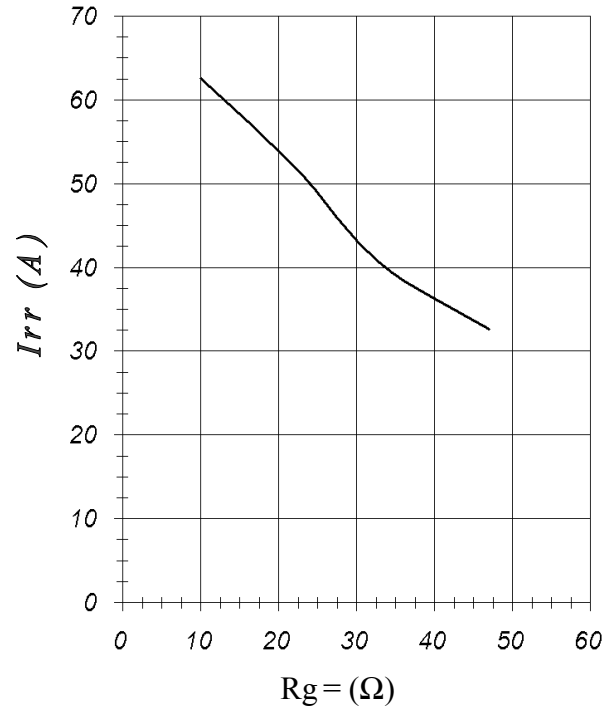

Fig. 19 – Typical Diode  $I_{RR}$  vs.  $dI_F/dt$   
 $V_{DC} = 400\text{V}; V_{GE} = 15\text{V}; I_F = 30\text{A};$   
 $T_j = 125^\circ\text{C}$

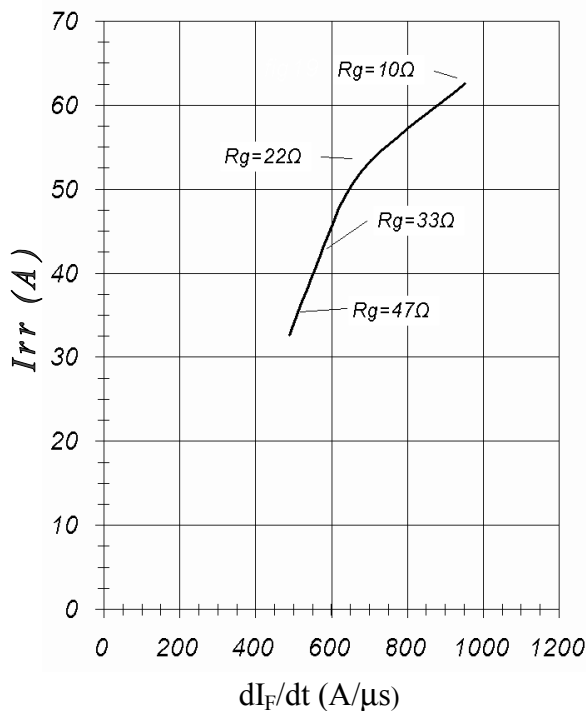

Fig. 20 – Typical Diode  $Q_{RR}$   
 $V_{DC} = 400\text{V}; V_{GE} = 15\text{V}; T_j = 125^\circ\text{C}$

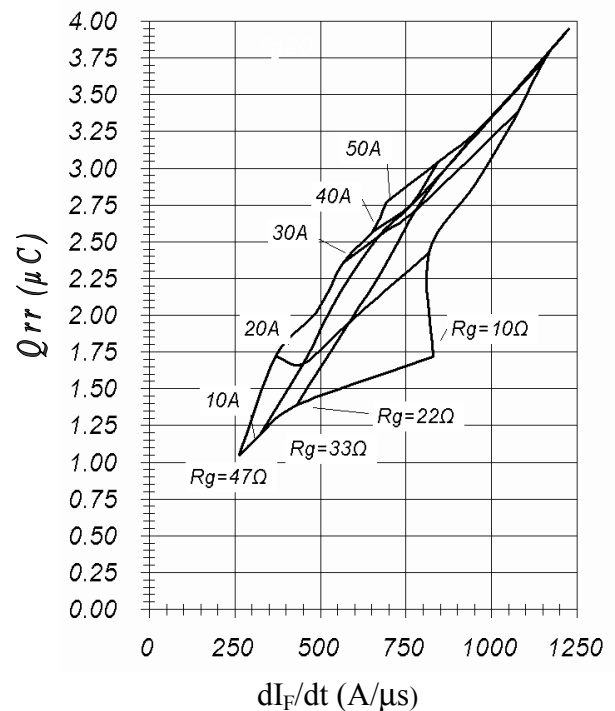

Fig. 21 – Typical Diode  $E_{REC}$  vs.  $I_F$   
 $T_j = 125^\circ\text{C}$

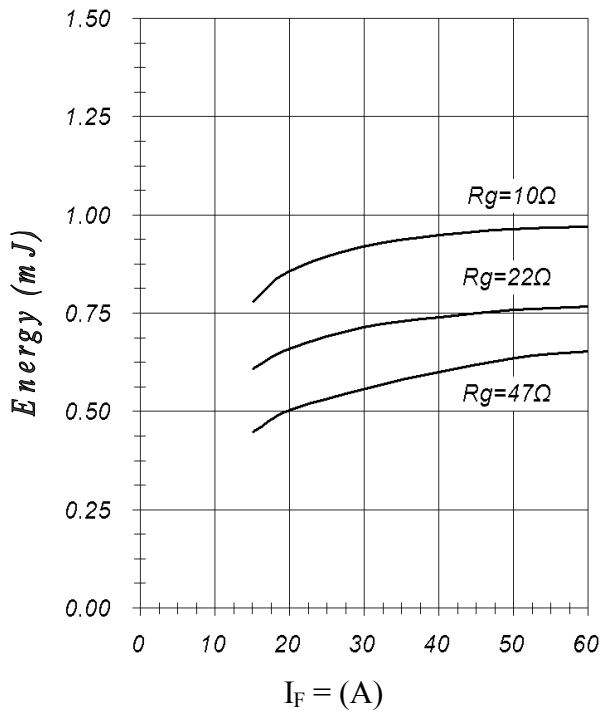

Fig. 22 – Typical Capacitance vs.  $V_{CE}$   
 $V_{GE} = 0\text{V}$ ;  $f = 1\text{MHz}$

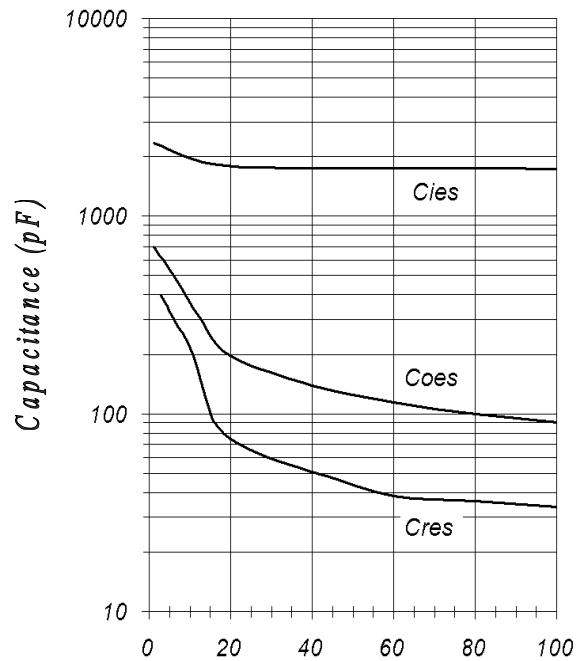

Fig. 23 – Typical Gate Charge vs.  $V_{GE}$   
 $I_C = 30\text{A}$ ;  $L = 600\mu\text{H}$ ;  $V_{CC} = 400\text{V}$

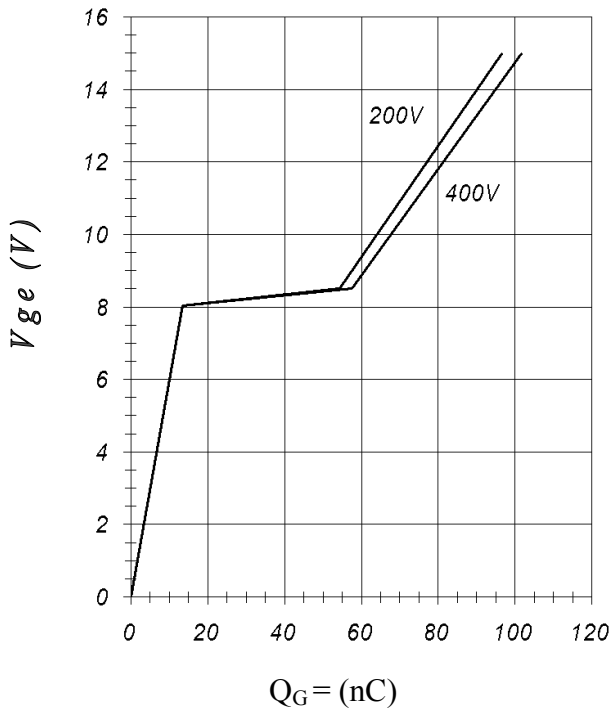

Fig. 24 – On state Voltage Drop characteristic  $V_{FM}$  vs  $I_F$   $t_p = 400\mu\text{s}$

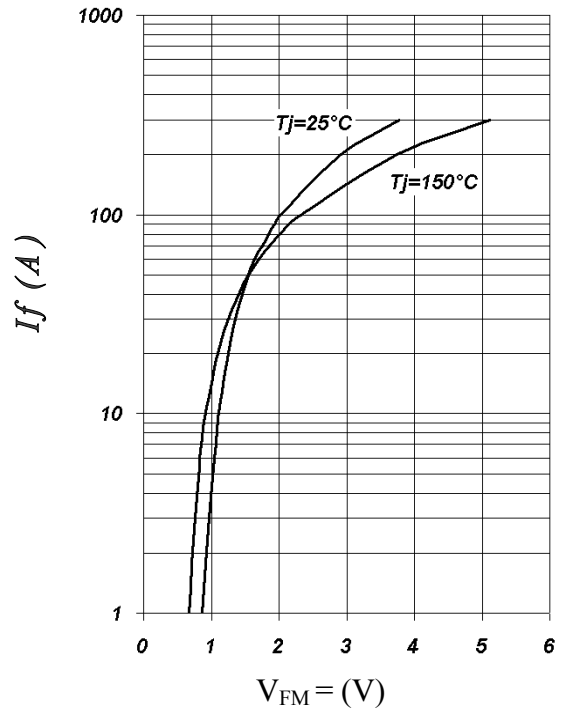

Fig. 25 – Normalized Transient Impedance, Junction-to-copper plate (IGBTs)

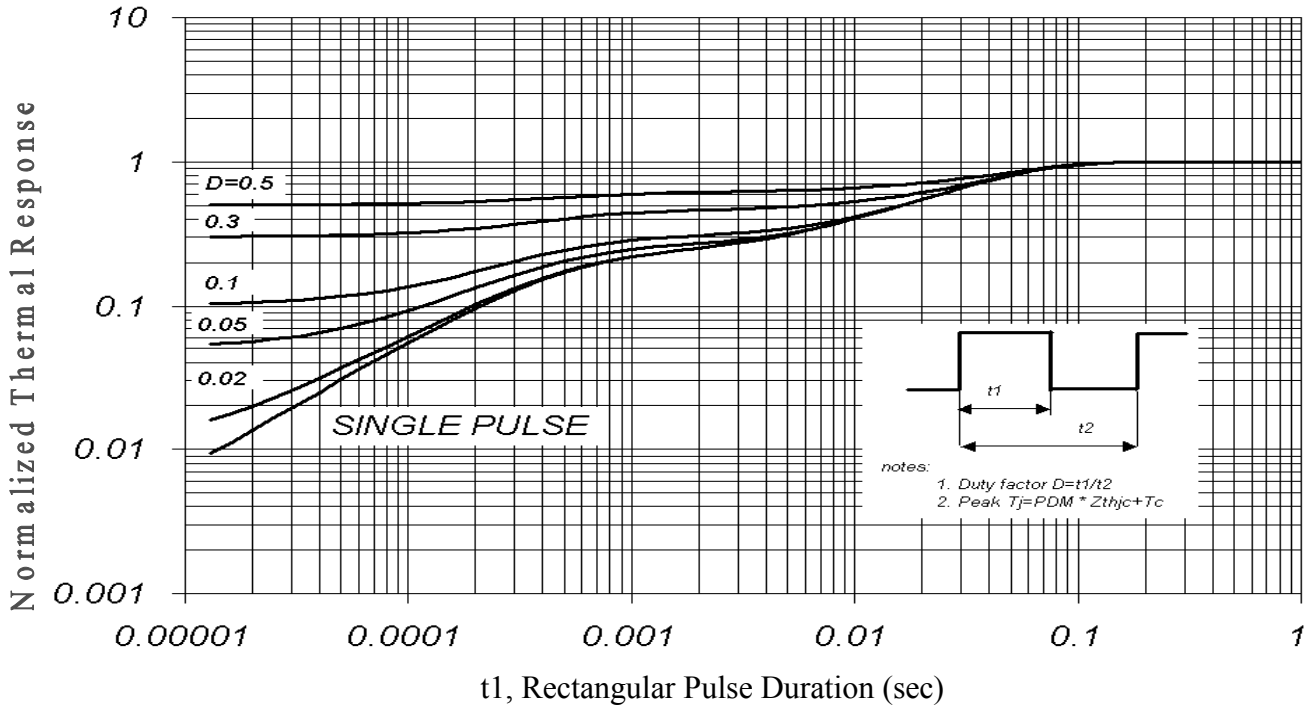
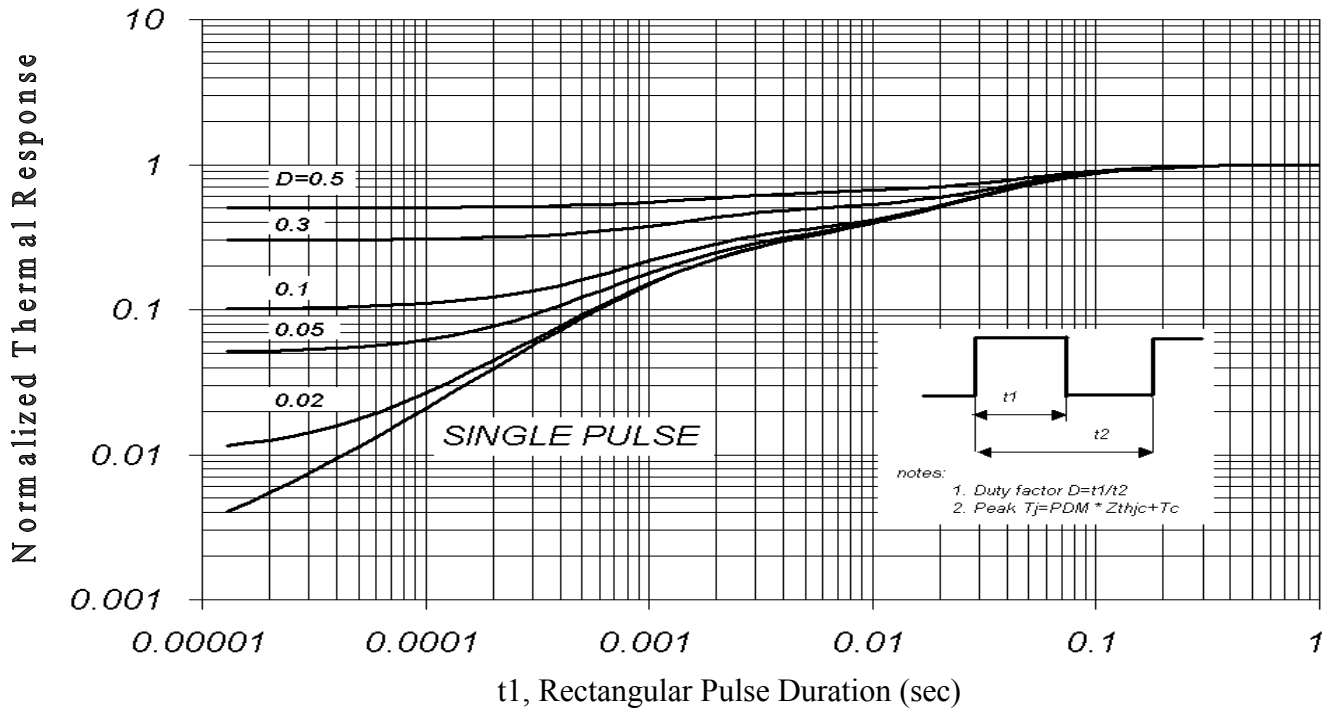
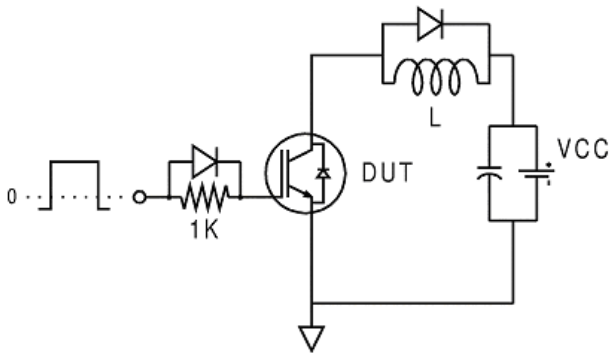

Fig. 26 – Normalized Transient Impedance, Junction-to-copper plate (FRED diodes)



**Fig. CT.1 - Gate Charge Circuit (turn-off)**



**Fig. CT.2 - RBSOA Circuit**

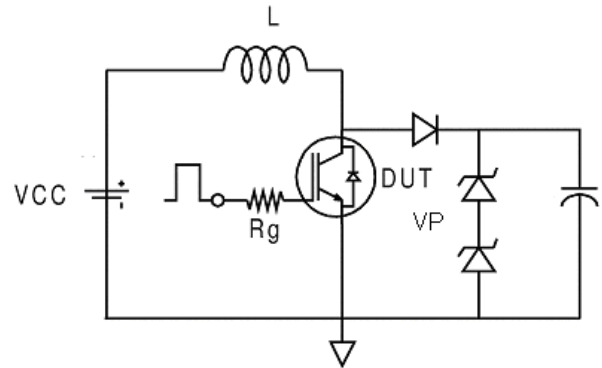

**Fig. CT.3 - S.C. SOA Circuit**

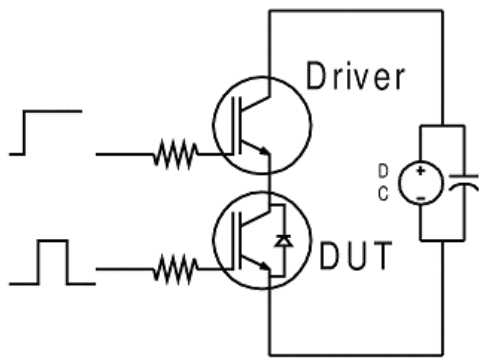

**Fig. CT.4 - Switching Loss Circuit**

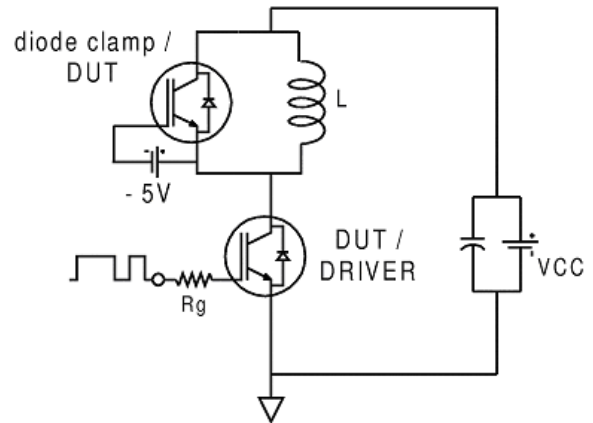

**Fig. CT.5 - Resistive Load Circuit**

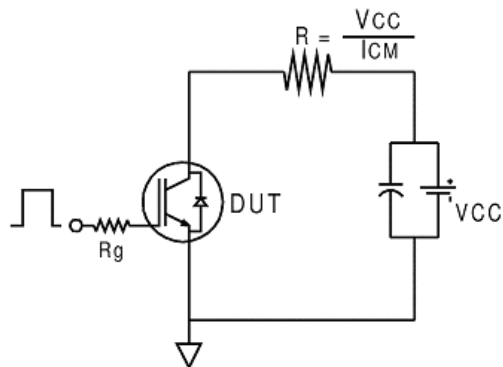

Fig. WF1- Typ. Turn-off Loss Waveform  
@  $T_J = 150^\circ\text{C}$  using Fig. CT.4

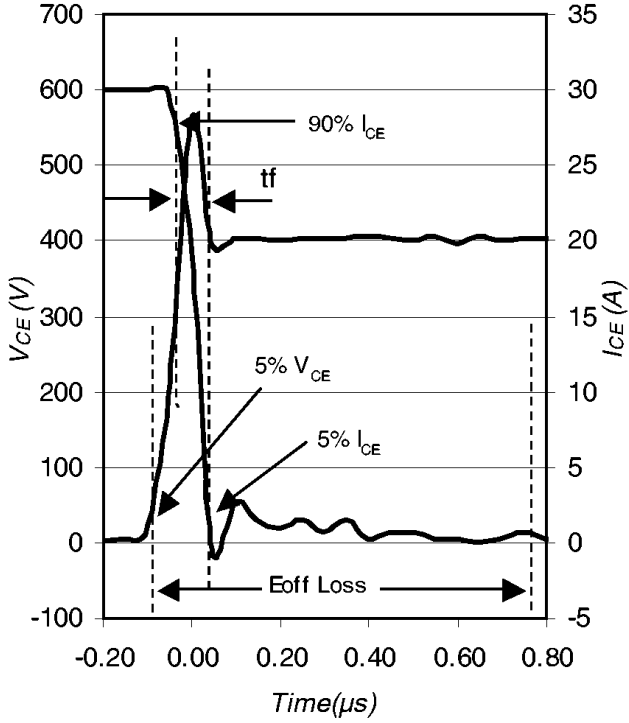

Fig. WF2- Typ. Turn-on Loss Waveform  
@  $T_J = 150^\circ\text{C}$  using Fig. CT.4

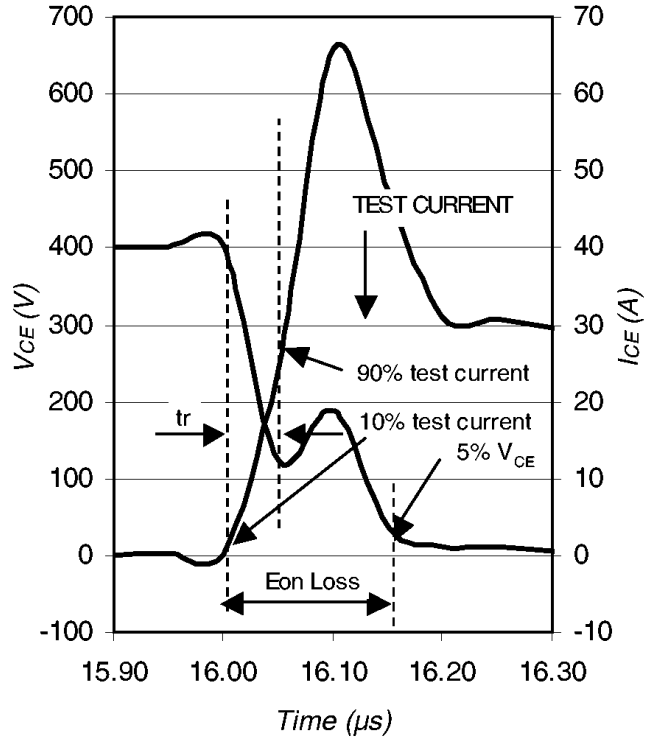

Fig. WF3- Typ. Diode Recovery Waveform  
@  $T_J = 150^\circ\text{C}$  using Fig. CT.4

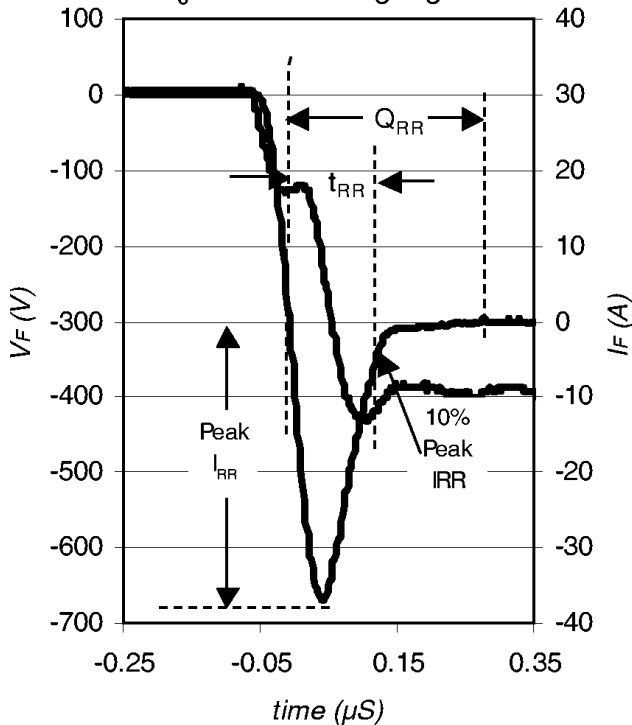
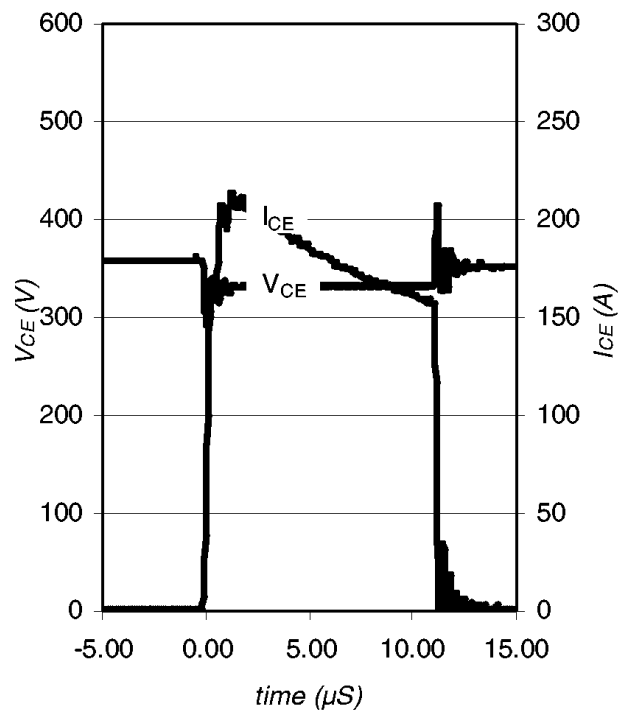
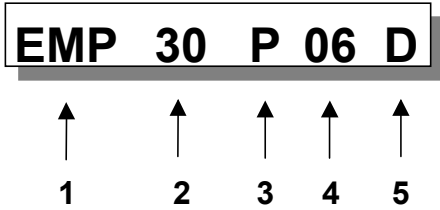

Fig. WF4- Typ. S.C Waveform  
@  $T_C = 150^\circ\text{C}$  using Fig. CT.3



### EMP family part number identification



1- Package type

2- Current rating

3- Current sensing configuration

4- Voltage code: Code x 100 = V<sub>rrm</sub>

5- Circuit configuration code

P= on 3 phases

Q= on 2 phases

E= on 3 emitters

F= on 2 emitters

G= on 1 emitter

A= Bridge brake

B= Inverter

C= Inverter + brake

D= BBI (Bridge Brake Inverter)

M= Matrix

EMP30P06D case outline and dimensions

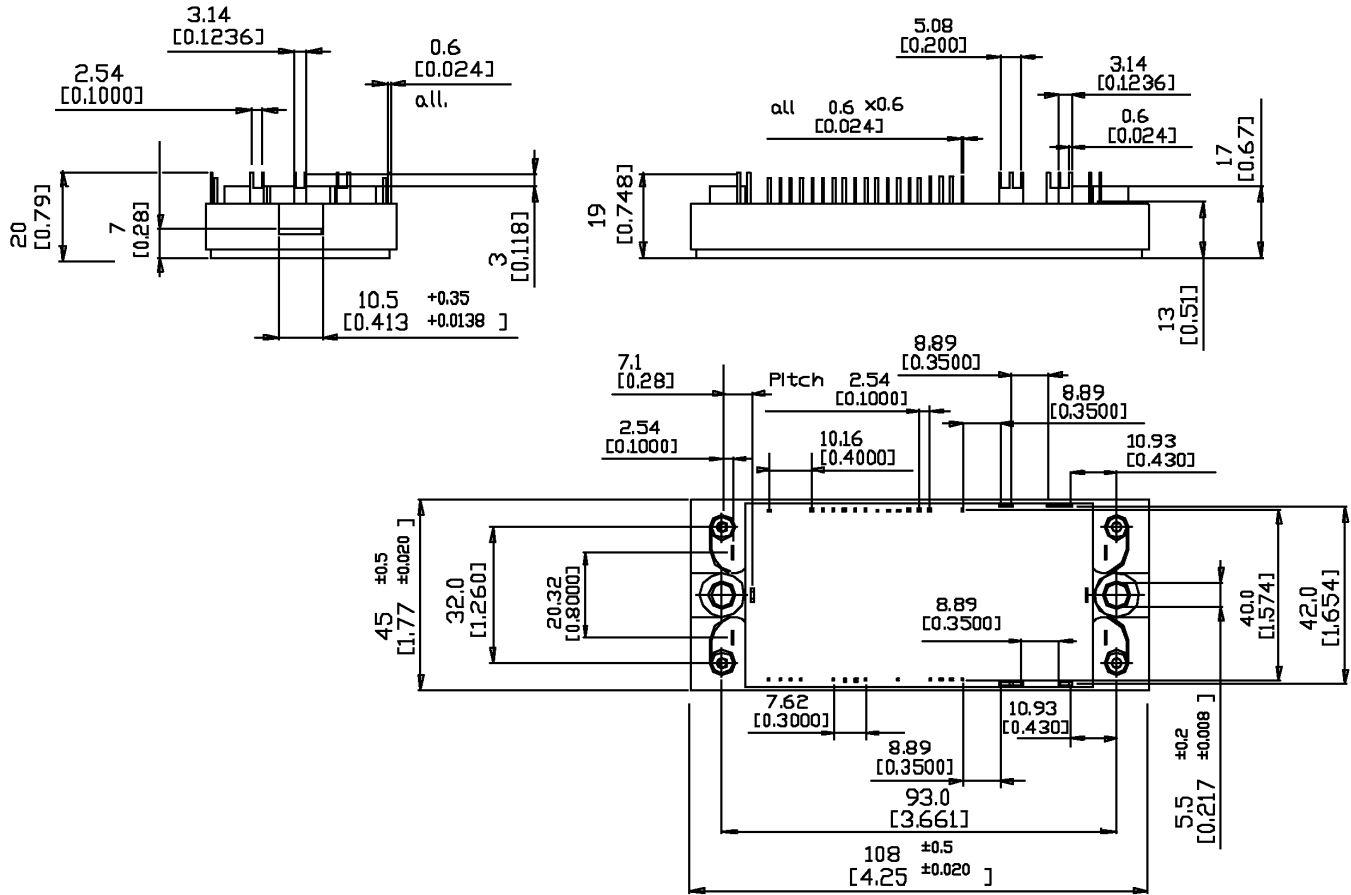

Data and specifications subject to change without notice  
This product has been designed and qualified for Industrial Level.  
Qualification Standards can be found on IR's Web Site.