

^SOLVING IGBT PROTECTION IN AC OR BLDC MOTOR DRIVE

The new IR2137 IGBT Gate Driver IC integrates Ground Fault and Over-Current Protection with Soft Shutdown.

1. INTRODUCTION

In the last decade, industrial AC drives have become more advanced in performance and more compact in size. This is largely due to the rapid development of power silicon technology, including the enhancement of IGBTs and of High Voltage Integrated Circuits. Additionally, this technological growth has been particularly accelerated for low horsepower (< 5 Hp) AC Drives. Yet, the ground fault protection, a feature sought increasingly in motor drives of all power levels, is available widely only in the high-end models due to the sensors and other circuitry involved. The market, however, continues to demand a fully protected, yet inexpensive, system. To meet this demand, International Rectifier has introduced the IR2137: a new generation 3-phase IGBT gate driver, featuring full IGBT protection and advanced soft shutdown features.

2. TRADITIONAL METHODS OF IGBT PROTECTION

This section outlines the traditional methods of protection, thereby allowing us to better appreciate the need for the IR2137.

2-1 Background Theory for Protecting Against Failure

One of the most common, and fatal, AC drive faults for IGBTs is the Over-Current condition. Table 1 outlines the causes for the 3 common Over-Current modes.

Over-Current Mode	Potential Causes
Line-to-Line Short	Mis-wiring, Motor leads shorting, Motor phase-to-phase insulation breaking down.
Ground Fault	Motor phase-to-phase insulation breaking down.
Shoot Through	False IGBT turn-on.

Table 1: Potential Causes of Over-Current

In order to protect IGBT devices effectively under an Over-Current condition, we need to focus on two factors.

First, one needs to detect the Over-Current mode and shut the system down. In both Line-to-Line and Shoot Through mode, the short-circuit current flows from and to the DC bus capacitors (Figures 1 and 3). Therefore, a shunt resistor in the ground path can detect these Over-Current conditions. However in the Ground Fault mode, the current flows from the AC line input, through the positive DC bus and high side IGBT, to the earth ground (Figure 2). Thus such an Over-Current condition must be detected either with a shunt resistor on the positive bus line or by detecting the current in the output lines.

Second, one needs to look at the AC drive architecture, and its influence on the method. For instance, Figure 4 shows a typical Floating Ground Reference Architecture, in which the micro-controller (μC) is on the Floating Ground reference, and therefore any Over-Current detection circuit needs to be isolated. Alternate architecture may require reduced or no isolation.

2-2 Traditional Methods of Over-Current Detection

Method 1

One can detect the Line-to-Line Short and Shoot Through currents by inserting a Hall Effect sensor or a linear opto isolator across the shunt resistor. The device should be in series with the negative DC bus line. For Ground Fault protection, an additional Hall Effect leakage current sensor could be placed either on the AC line input or on the DC bus. The protection circuit is then implemented by using fast comparators. The output of these comparators is 'OR'd with the micro-controller or PWM generator to initiate the shutdown of the gate signals.

Method 2

If located in the motor phase output, each Hall Effect sensor uses 2 comparators. This is done because both positive and negative current polarities flow during a Line-to-Line Short condition. Another important consideration is the total propagation delay for shutdown. The delay time associated with the optical isolators in the gate drive and the Hall Effect sensor is typically more than 2 microseconds. Therefore, regardless of protection circuitry implementation, this delay should be added to the circuit delay, before matching it with the IGBT short circuit duration time. As shown in Figure 4, the configuration requires 2 Hall Effect sensors and/or opto isolators in addition to the protection circuit. The protection circuitry comprises of comparators (2), voltage references, capacitors, and resistors.

Method 3

Another protection method is to use an IGBT de-saturation circuit. This discrete circuit can be constructed in the secondary side of the opto gate driver. (Opto isolated devices with built-in de-saturation circuits can also be found in the market). This circuit detects voltage build-up across the collector and emitter while the device is fully on. If the voltage exceeds a specified limit, the associated gate signal is shut off. A discrete circuit would require a comparator with voltage reference, a high voltage diode, and various resistors and capacitors.

2-3 Traditional Methods of Over-Current Shutdown

For shutting down an IGBT when an Over-Current condition is detected, a soft turn-off is preferred because it reduces a high voltage spike across the collector and emitter of the IGBT device at fault. Thus it provides a wider margin for the RBSOA limit during a short-circuit condition and the snubber circuit can be significantly minimized or even eliminated. When implemented in the discrete circuit based on the floating ground

reference architecture, a soft turn-off circuit can get very complex. Each IGBT gate drive circuit requires an additional fast opto isolator and soft turn-off circuit with the dedicated totem pole buffer transistors. Given circuit costs and complexities, a snubber circuit is preferred to the discrete soft shutdown circuit. For low Hp devices, the snubber circuit can be implemented with a high frequency type capacitor across the DC bus, near the IGBTs.

2-4 Problems with the Traditional Method

A. Circuit Control Problems

In a soft shutdown scheme, simultaneous shutdown of all 6 IGBTs is required to prevent a potential false turn-on while the IGBTs are in the soft shutdown mode. If a high side IGBT is turned off softly while the other IGBTs are in the middle of a switching transition within a PWM period, that IGBT can unintentionally be turned back on. It is extremely difficult to synchronize simultaneous shutdown using traditional architecture.

B. Part Count, Size, and Cost Problems

If the system requires full IGBT protection, including Ground Fault protection, and if it is based on the floating ground reference architecture, then the gate drive and protection circuit require the following major components even without the soft shutdown feature:

- 6 fast opto isolators
- 2 fast Hall Effect sensors or fast linear opto isolators
- 2 comparators
- 4 floating 15V power supplies

Hall Effect sensors and opto isolators are relatively large and bulky, thus requiring a lot more space than a monolithic IC. In addition, if the system requires a soft shutdown function, 6 additional opto isolators and 6 buffer circuits (with a provision for soft turn off capability) are required. Thus, whereas low Hp AC drive systems are today moving toward smaller sizes, the above solutions provide neither the simplicity nor the integration of the gate drive and protection circuitry that is needed.

The total cost, including assembly of the inverter system, is large due to the large number and bulkiness of components. Furthermore, components such as the Hall Effect sensors are still subject to manual assembly.

To circumvent these issues, a small, integrated IC device that is capable of performing all the above functions is a necessity.

IR2137: 3-PHASE GATE DRIVER WITH INTEGRATED IGBT PROTECTION

International Rectifier has now introduced the IR2137 into the AC drives market. This latest High Voltage Integrated Circuit provides a monolithic solution to driving all six IGBT gate drivers, while simultaneously providing full IGBT protection and soft shutdown. In contrast to the Floating Ground Reference architecture discussed in the

previous section, the IR2137 circuit enables a simple structure. The differences between the two architectures are summarized in Table 2.

	Floating Ground System	IR2137 solution
Gate Drive	Six Fast Optical Isolators	IR2137
IGBT Protection	Two Hall Effect sensors and Two comparators	IR2137 integrated function with a shunt resistor and a comparator
Additional Circuits	Four floating power supplies	Eliminated (boot strap power)
	Snubber circuit or discrete soft shutdown circuits	Eliminated by integrated soft shutdown function
	Brake IGBT drive circuit with a optical isolator	Eliminated by integrated brake IGBT driver circuit

Table 2: Solution Comparison of Gate Drive and IGBT Protection

For the IR2137 circuit, as shown in Figure 5, the IR2137 and a micro-controller (μC) share the same ground potential – the negative DC bus potential. (This architecture is already the industry standard in the micro AC inverter drive segment). Unlike its traditional counterpart, the IR2137 circuit requires a single shunt resistor and associated comparator. With this, it can perform all modes of IGBT short circuit protection.

Additionally, the IR2137 contains IGBT de-saturation logic in the circuit of each high-side gate drive. In the event of a Ground Fault condition, the DESAT pin is activated, and the fault signal is transferred to the low side fault logic circuit. The low side fault logic then initiates the simultaneous soft shutdown of all 6 IGBTs. When the soft shutdown signal is transferred back to the high side, the active PMOS/NMOS transistor buffer goes into a high impedance mode and another weak NMOS transistor becomes active to slowly drive the gate pin low. The shutdown softness can be programmed by adding an external resistor to the SSD pin – thus allowing the user to optimize softness for the specific gate charge of the IGBT. To eliminate the dv/dt induced false triggering of the DESAT pin, there is a blanking filter delay of 2 microseconds at each high-side gate turn-on transition.

Figure 8 shows the oscillogram of the ground fault protection feature in the IR2137. In this measurement, a size 4 IGBT, IRG4BC40KD, was used in conjunction with a turn-on resistor, $R_g = 33\Omega$, turn-off resistor, $R_g = 16\Omega$, and softness resistor, $R_{SSD} = 500\Omega$. The top trace in Figure 8 is the IGBT gate signal (10V/div), while the middle trace is the V_{CE} voltage (100V/div), and the bottom trace is the IGBT short circuit current (40A/div). No snubber circuit was used for this test. One can see that the de-saturation protection activates quickly and the soft shutdown feature virtually eliminates the overshoot voltage across the collector and the emitter.

For comparison, the oscillogram of a ‘hard’ shutdown is shown in Figure 9. The same IGBT, IRG4BC40KD, and the same PCB pattern were used as in the example shown in Figure 8. The top trace is the IGBT short circuit current and the bottom trace is the IGBT V_{CE} voltage (100V/div). As can be seen in Figure 9, the overshoot voltage reaches approximately 100V above the normal V_{CE} voltage during the turn-off transition.

In summary, the IR2137, a monolithic IC, provides excellent protection and soft shutdown features in an extremely compact and cost-effective package.

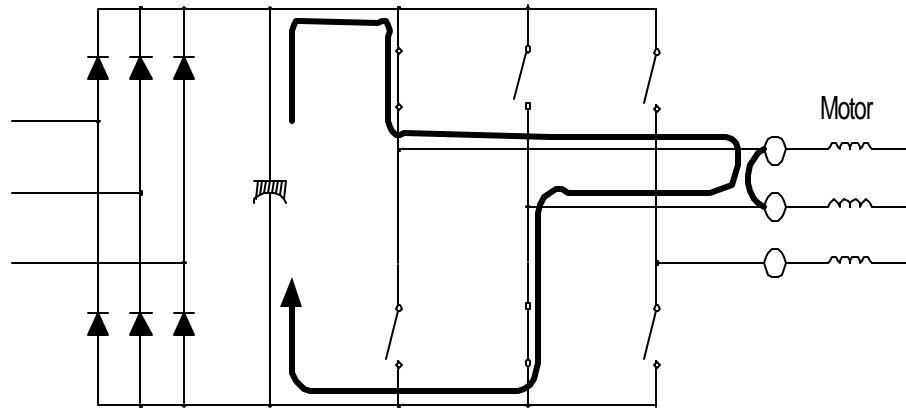

Figure 1: Current Flow during Line-to-Line Short

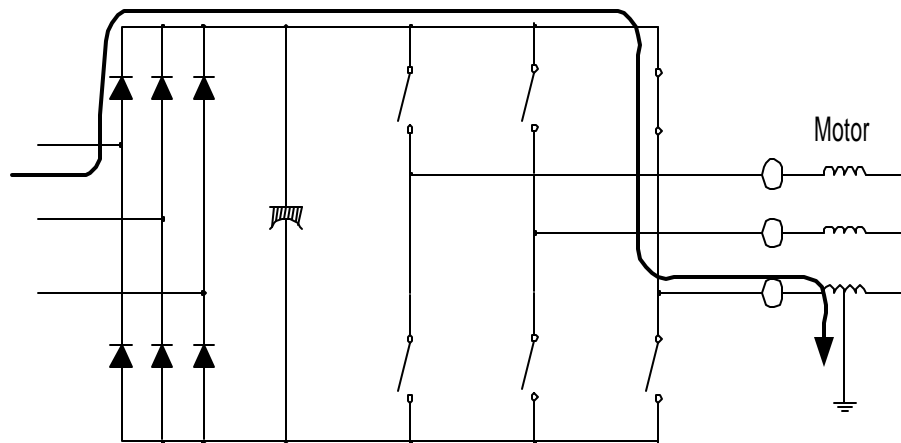

Figure 2: Current Flow during Ground Fault

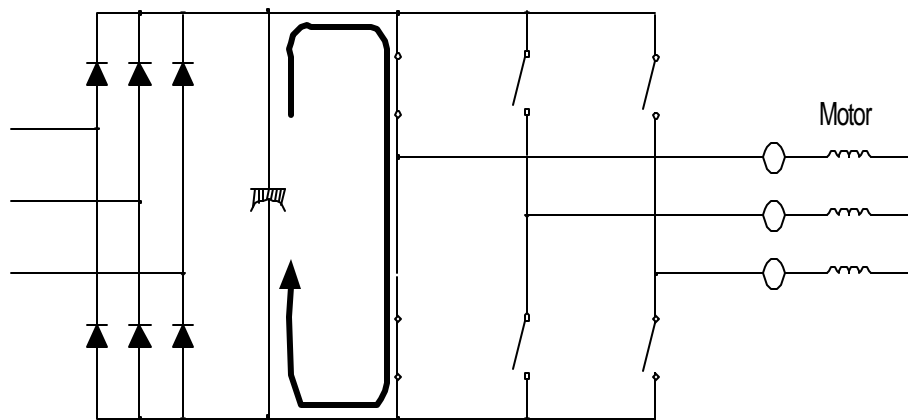

Figure 3: Current Flow during Shoot Through Mode

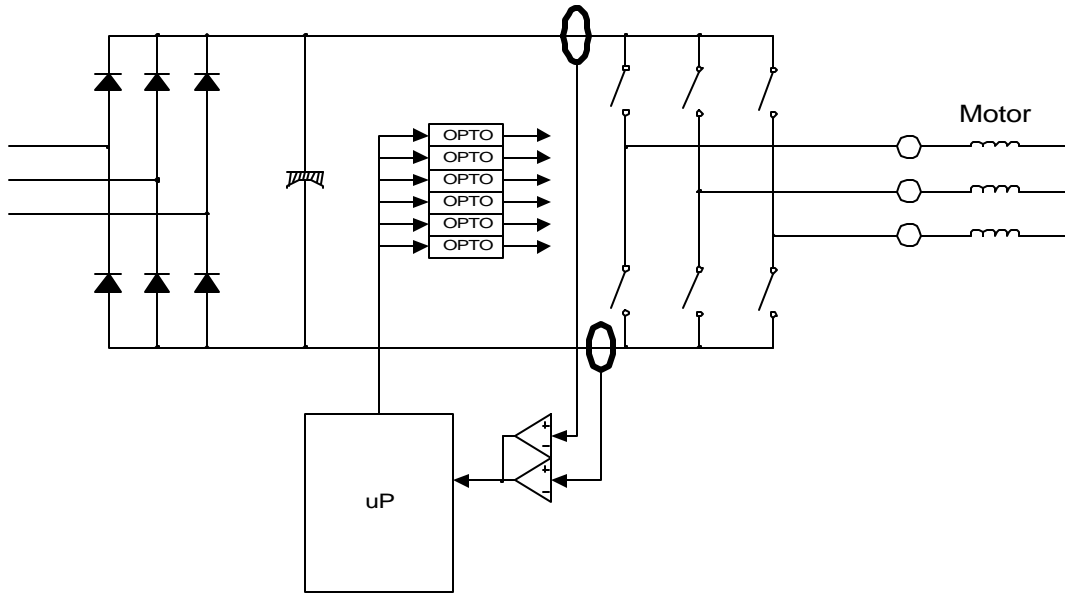

Figure 4: Overcurrent Protection in Floating Ground Reference System

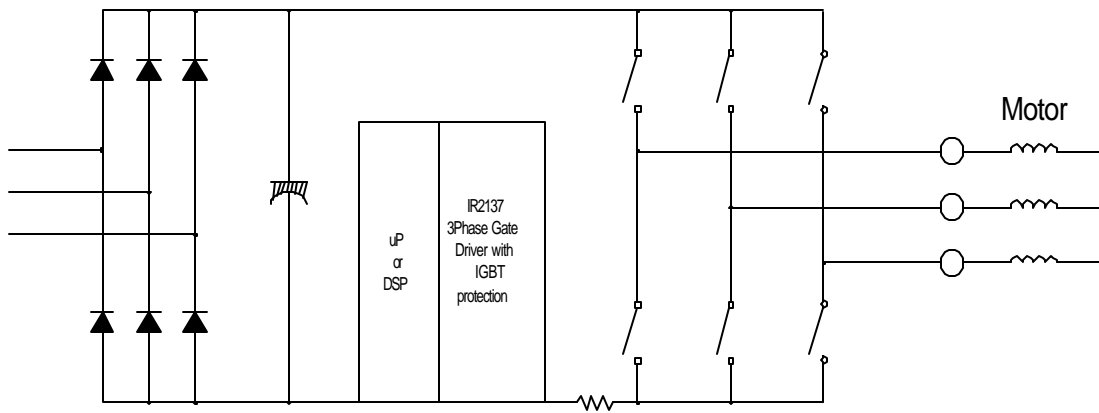

Figure 5: IR2137 Gate Driver with IGBT Overcurrent Protection

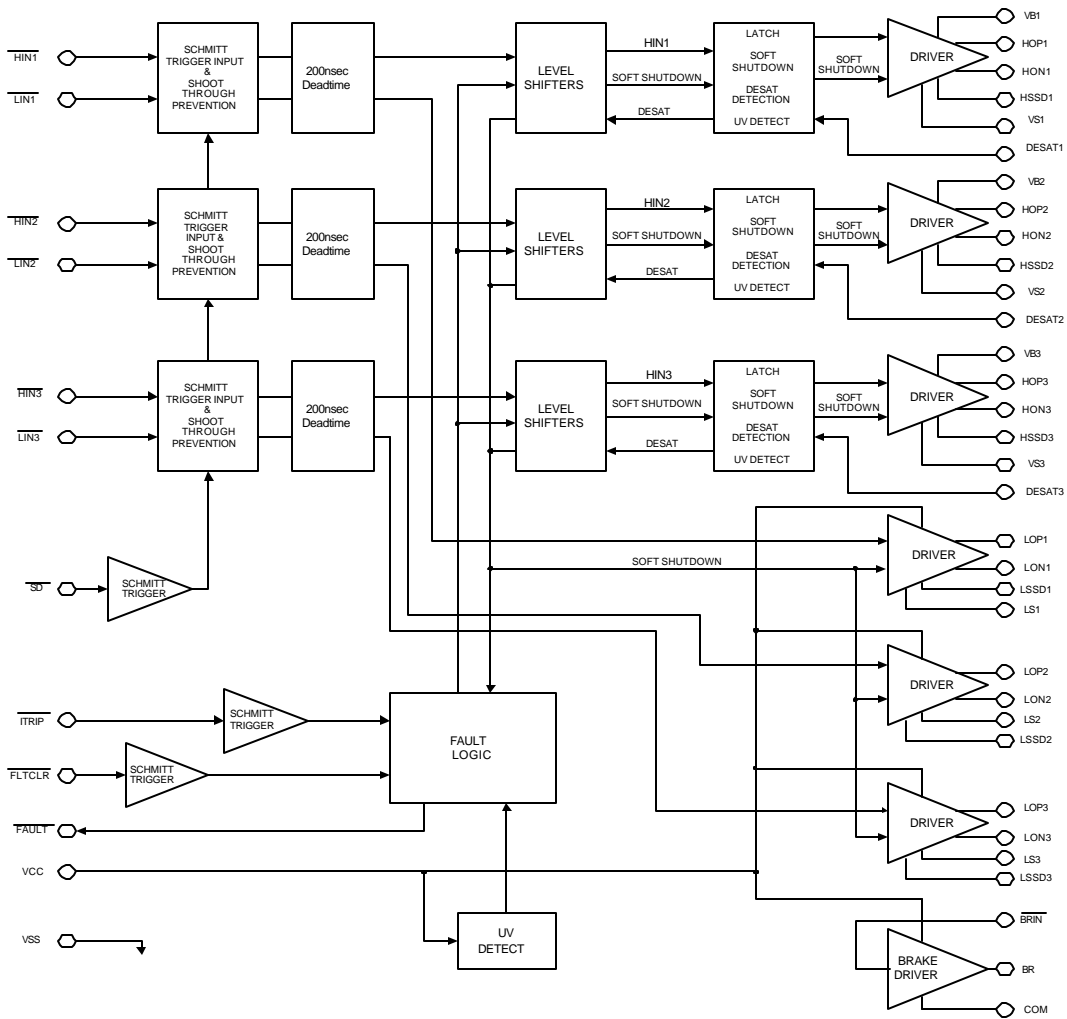

Figure 6: IR2137 Block Diagram

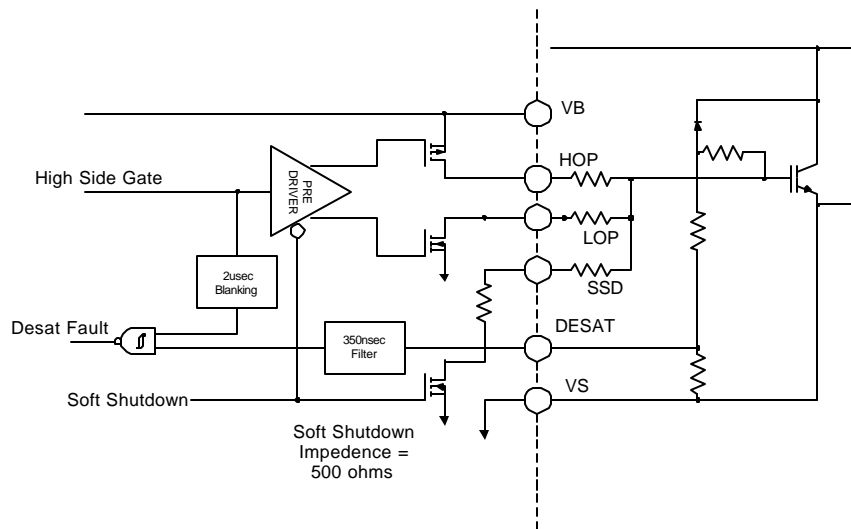

Figure 7: IR2137 High Side Circuit

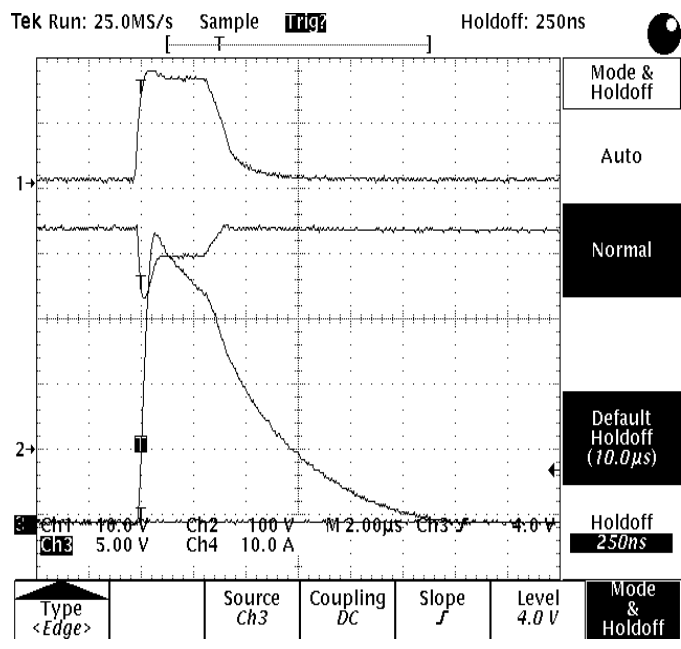

Figure 8: IR2137 Soft Shutdown

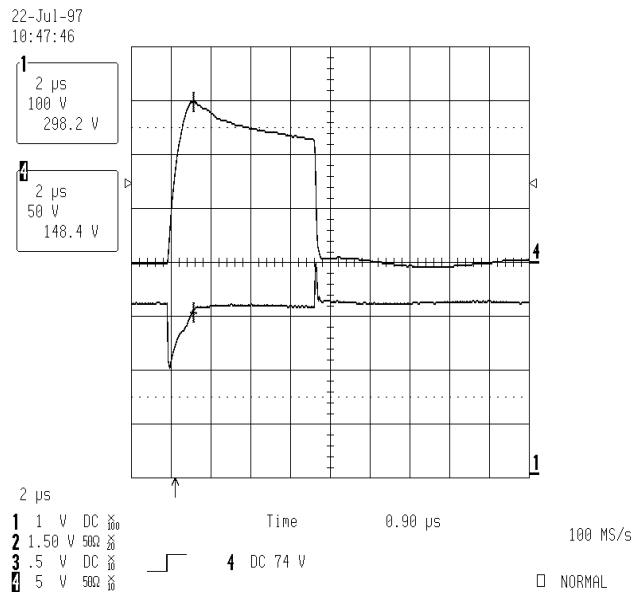

Figure 9: Hard Shutdown