

LOW GATE CHARGE HEXFETS SIMPLIFY GATE DRIVE AND LOWER COST

by László Király

Introduction

Fast switching of power MOSFETs requires rapid transfer of the gate charge in a short period of time. High peak output current capability MOS Gate Drivers (MGDs) can deliver high current spikes for fast switching, but the parasitic wiring and package inductances limit the gate current and slow-down the switching. Minimizing the inductances at the gate by reducing the distance between the driver and the MOSFET is essential but hard to achieve in medium and high current system because of the physical dimensions of components and limitations inherent to the printed circuit board layout. The parasitics inductances at the gate are also responsible for excessive ringing and oscillation in the circuit.

New Low Charge HEXFETs give the designer a choice of higher switching speed or cleaner waveforms with a simplified and less expensive gate drive. The smaller gate current reduces the effects of parasitics and results in cleaner wave forms, and reduced switching losses.

1. Reducing capacitances for lower Gate Charge

MOSFET capacitances change over a wide range in nonlinear fashion with applied voltage. As indicated in Ref [1], the use of gate charge figures for switching speed calculations and gate drive design provides more accurate results than calculations based on capacitance values. However to reduce the gate charge requirement of a MOSFET, the internal capacitances that need to be reduced. The capacitances impact gate charge most are shown in Figure 1.

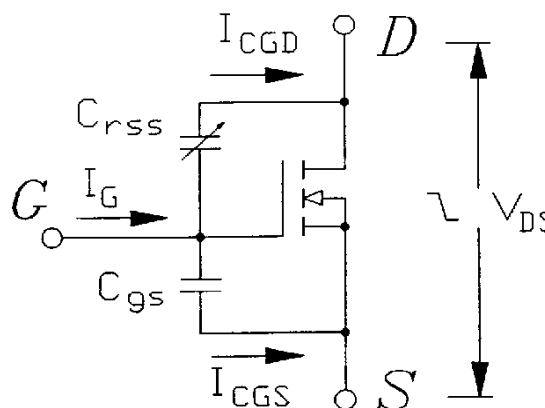

FILE: LOGGCAPS.DWG

Figure 1
Simplified equivalent circuit of a MOSFET with internal capacitances at the gate.

When the drain voltage changes, most of the gate drive current goes into the C_{rss} (or Miller) capacitance. In fact, the dv/dt during the voltage rise and fall times is limited by the rate at which the gate drive circuit can support the charging and discharging of this capacitance. During this time the gate voltage is substantially flat, as shown in Figure 3, indicating that no charge goes into the C_{gs} capacitance. On the other hand, a change in gate voltage indicates that charge is being taken by the C_{gs} capacitance.

It follows that, for a given gate drive, voltage transitions can be accelerated by reducing the Miller capacitance, while a reduction in C_{gs} reduces delay times and gate current requirements.

2. Comparing Low Q_g and standard devices

The test circuit of Figure 2 measures gate charge characteristic and can be used to compare switching times at low gate currents.

Q1 serves as a constant current generator feeding 10mA current to the gate of the MOSFET at turn-on. The small gate current slows-down the switching, so that the circuit generates clean wave forms, free from the effects of parasitic inductances and capacitances.

Figure 3 compares the gate waveform of an IRF740 with that of the new IRF740LC Low Charge HEXFET. Since constant current is supplied to the gate the horizontal time scale is directly proportional to the gate charge so that it can be scaled in nanoseconds and in nanoculombs.

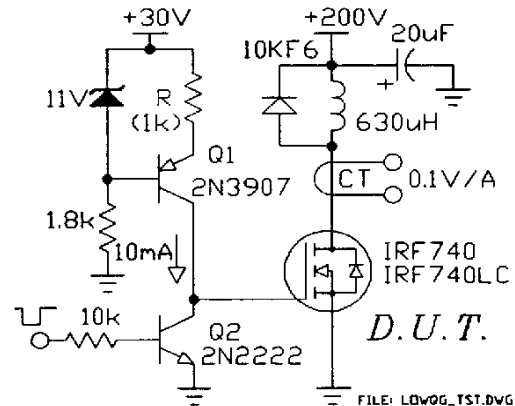

Figure 2
Test circuit for gate charge measurements.

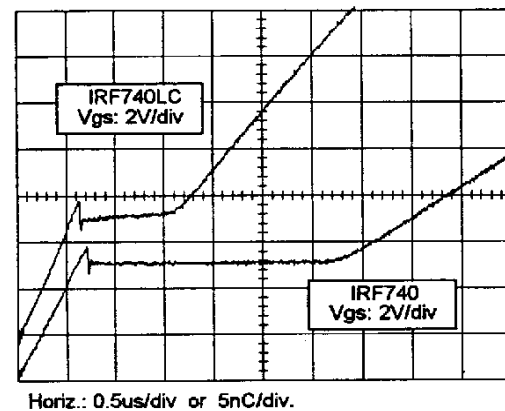

Figure 3
Gate wave form for IRF740 and IRF740LC low gate charge MOSFETs. The devices are switching 4A inductive load at 200V.

Considering that at the end of the flat portion of the gate charge curve, the drain voltage switching is completed, Figure 3 shows that the IRF740LC requires half the gate charge when compared to a standard IRF740. Most of the improvement is due to reduction of the C_{rss} capacitance as the shorter plateau indicates in the gate charge curves.

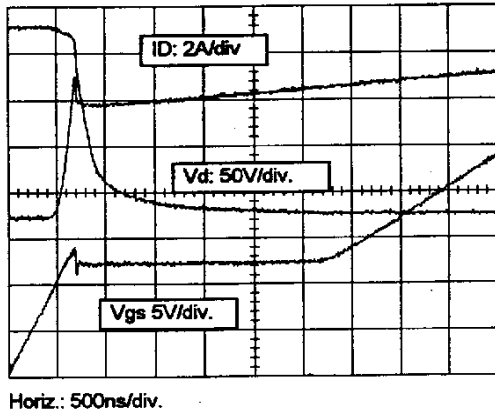

Figure 4
IRF740 switching a 5A inductive load at 200V with 10mA gate drive current.

The effect of reduced gate charge on switching speed is illustrated in Figure 4 and Figure 5. In both cases the MOSFETs are switching 4A inductive load current at 200V. We have chosen the unusual gate drive circuit of Figure 2 because it gives clean waveforms unaffected by circuit parasitics. This simplifies the task of comparing the relative merits of the two devices. Section 3 and 4 deal with real circuit applications.

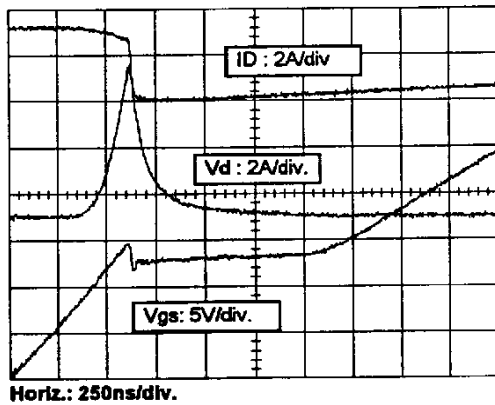

Figure 5
Switching wave form for the low gate charge IRF740LC MOSFET.

The difference in turn-on delay is not significant, but the shorter plateau for the low gate charge device, results in 2.5 times faster switching compared to the standard device (notice that scales are different).

3. Use of Low Charge HEXFETs helps save on gate drive.

Driving large die standard MOSFETs like the IRF740 in half bridge applications, (at frequencies over 50kHz) requires the use of an MGD like the IR2110 with high output current capability (Figure 6).

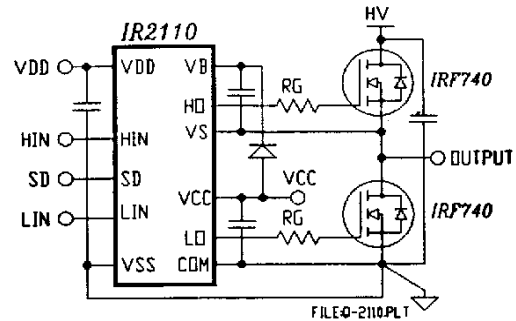

Figure 6
Half bridge built with regular MOSFETs and IR2110 MGD.

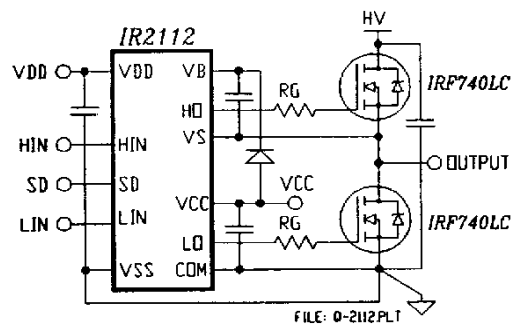

Figure 7
Low power version of circuit shown in Figure 6. Parts cost can be reduced using low gate charge MOSFET and an IR2112 MGD.

Using Low Charge HEXFETs as shown in Figure 7, the IR2110 can be replaced by the low cost, lower output current capability IR2112 MGD.

Depending on the device being driven, this may have to be coupled with a reduction of the gate resistance, as the Low Charge devices require 40% less gate charge, while the current sourcing and sinking capability of the IR2112 are lower than 40% of the IR2110.

4. New Designs with Low Charge HEXFETs and retrofitting into old designs

It should be remembered that the speed of a MOSFET is limited not so much the device itself, as by the stray parameters, inductive couplings and gate drive. In new designs, to take advantage of the higher speed of the Low Charge HEXFETs the layout and gate drive must be suitable for the desired speed.

On the other hand, since Low Charge HEXFET tend to be faster, a direct replacement of a standard MOSFET, not supported by layout improvements, can cause additional ringing and EMI. If this is a problem, it can be easily corrected with a higher value gate resistance (Figure 8).

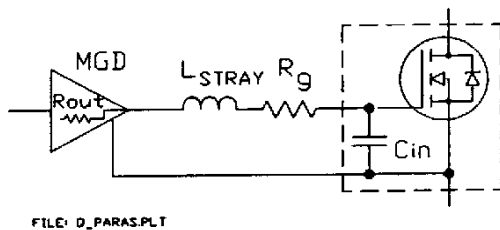

Figure 8
Drive circuit and MOSFET with parasitics.

In this case the benefits of superior speed would not be realized, on account of layout limitations.

An additional benefit that results with a higher value of gate resistor is that it lowers the peak gate current and reduces the adverse effects of circuit parasitics so that, for the same switching speed, there is an improvement in waveform quality. This is true for new designs that cannot take advantage of speed improvements, as well as old designs suffering from oscillations and ringing.

Conclusion

The new Low Charge HEXFETs simplify gate drive requirements. The drive power to the gate can be reduced and smaller, lower current gate drives can be used at lower cost. The lower peak currents at the gate, reduces the effects of the parasitic inductance at the gate and results in clean wave forms and reduced switching losses.

Using standard Low Charge HEXFET in place of a standard MOSFET requires a change in the R_g resistor. R_g usually needs to be increased to slow-down the switching with a general improvement of waveform quality.

References

1. AN-944A: A New Gate Charge Factor
2. AN-937B: Gate Drive Requirements