

## KEEPING THE BOOTSTRAP CAPACITOR CHARGED IN BUCK CONVERTERS

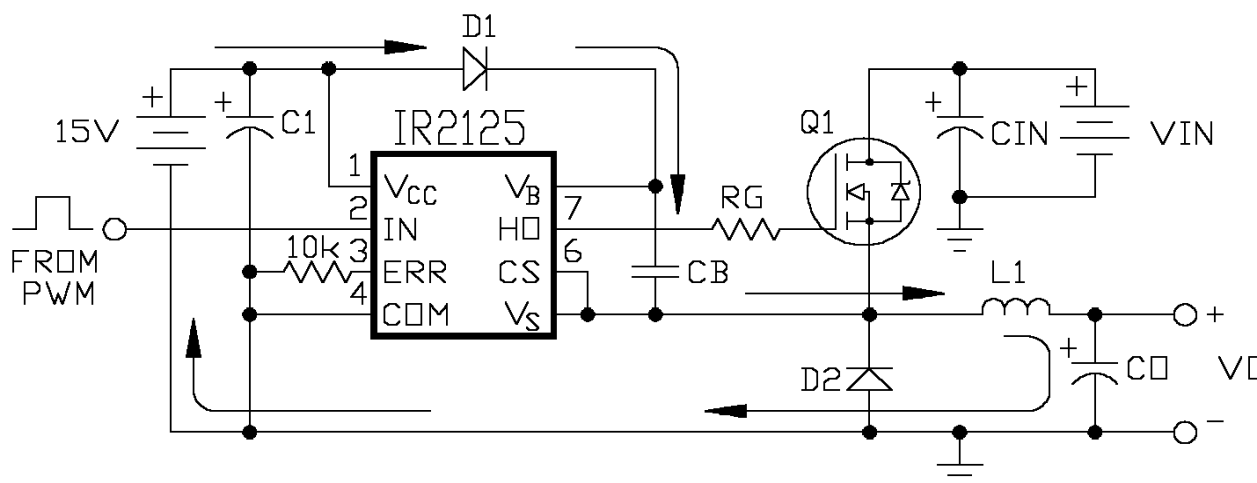
By Laszlo Kiraly

### INTRODUCTION

For simplicity, all the examples below make reference to the IR2125. However, they are equally applicable to all of the Control IC devices.

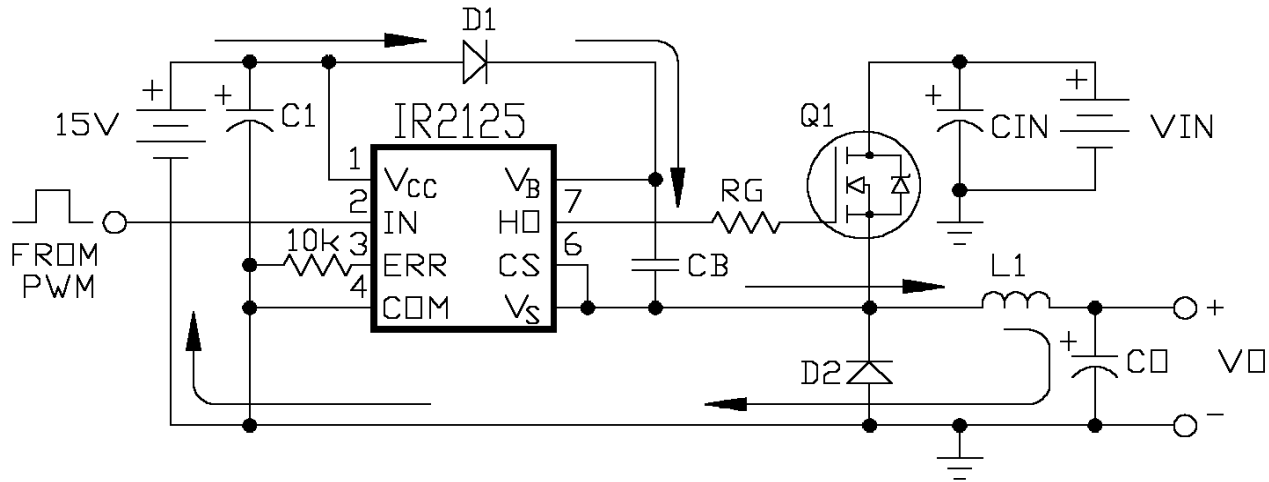
In a buck converter the capacitor may fail to charge in some unusual circumstances:

- at start-up with no load (Figure 1)
- start-up in battery charger applications (Figure 2)
- stop/restart (Figure 2)
- operation with low load (Figure 3)



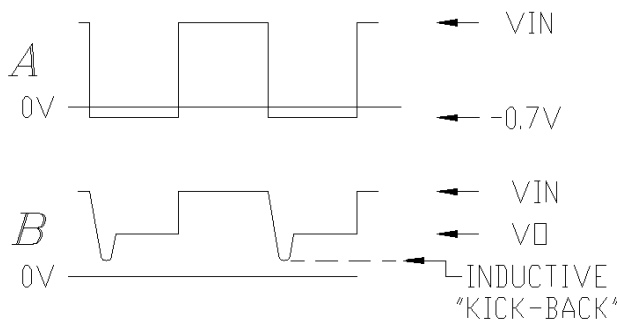
**Figure 1**

During start-up with no load, the charge current of CB also charges the CO capacitor at the output.  
For successful no-load start-up  $CO \geq 10 \times CB$  is recommended.

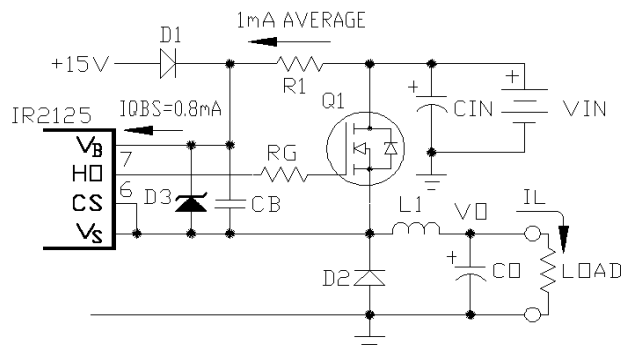

**Figure 2**

In battery charger applications, the +12V from the output appears at the  $V_S$  lead and reduces the voltage across CB at start-up and the undervoltage protection in the IR21XX inhibits the operation.

**Stop-restart.** Duty cycle may go to zero or an external shutdown command may interrupt operation. Sudden removal of heavy load at the output often results in higher output voltage than the set value due to the limited speed of the control loop and the stored energy in the L1 inductor. With no load or light load at the output CO capacitor can keep the output high for long time while the CB is being discharged at faster rate by the  $I_{QBS}$  current of the high-side driver. (see Figure 3b for a selection)


**Figure 3a**

During normal operation, when the MOSFET turns off, the inductor forces the freewheeling diode into conduction (upper curve). This holds  $V_S$  close to ground so that CB gets fully recharged through D1. Low inductor current results in small inductive kick-back,  $V_S$  remains high, and the circuit fails to recharge CB. (See Figure 3b for a solution).


**Figure 3b**

Adding R1 to the circuit, charging current can be derivated from VIN. Because VIN is higher than VO, some charging current always flows through R1 even if the  $V_S$  lead is sitting at VO potential. To keep CB charged, the average current through R1 should be higher than the worst case  $I_{QBS}$  current. D3 should be a low level zener diode with sharp knee at low currents. The recommended part numbers for 12V and 15V are respectively: 1N4110 and 1N4107.