

Application Note AN-1047

Graphical Solution to Two Branch Heatsinking Safe Operating Area

Table of Contents

	Page
1. Background	1
2. Second Generation iPOWIR	1
3. Example Solution	2
4. Procedure for determining SOA	2
5. Deriving the SOA curve	2

A graphical technique for determining proper thermal and heatsinking for iPOWIR™ devices is presented.

Graphical solution to two branch heatsinking Safe Operating Area

By Steve Brown—Director, iPOWIR Design Center

Background

First generation iPOWIR™ products were designed so that virtually all of the heat could be removed from the bottom of the package through the PCB. This allowed for a simple thermal model (Fig #1) and specifications to keep internal junction temperatures (T_J) within acceptable limits.

An important iPOWIR design goal was to avoid complicating the data sheet specification by specifying thermal resistance, and then forcing the user to figure out safe operating area (SOA). Defining junction-to-

PCB thermal resistance (R_{THJB}) in a multi-chip module can be problematic because the hot spot of the module moves back and forth between components depending on operating conditions. Also, once R_{THJB} is specified, it is necessary to provide a standardized way of measuring it. Package integrated power solutions do not lend themselves to traditional thermal resistance measurement techniques.

For Gen 1 iPOWIR devices, these issues are avoided by carefully characterizing the package thermally at design time using infrared metrology and specially made iPOWIR devices with built in temperature sensors, and then specifying SOA appropriately. SOA was then based solely on PCB temperatures adjacent to the device.

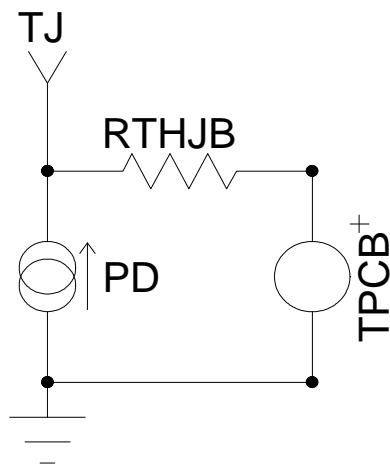

Fig #1: Gen 1 iPOWIR thermal

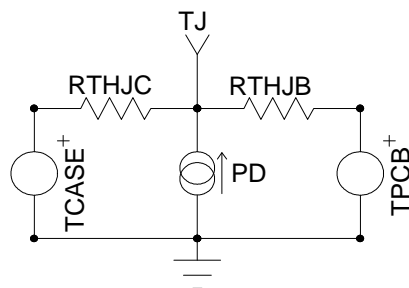

Fig #2: Gen 2 iPOWIR thermal

While simple and effective, there are instances when it is desirable to extract heat from the top of the package by using a heatsink in direct contact with the iPOWIR package. This simplified rating system did not lend itself to that sort of thermal solution, and in any case, heat extraction from the top of the package was inefficient due to the materials and design of the package.

Second Generation iPOWIR

Second generation iPOWIR products (Fig #2) are being designed to allow significant heat extraction out of the top of the package, as well as out through the PCB it is mounted on. This provides additional flexibility to the user for thermal solutions, but introducing junction-to-case (R_{THJC}) comes at the cost of an increase in complexity for determining the SOA of the device.

In this case the iPOWIR design goal was to maintain the thermal design simplicity of the Gen 1 iPOWIR device as much as possible for Gen 2 power blocks. To fully achieve this goal, it is necessary to reduce the two branch Gen 2 thermal model (Fig #2) to the one branch thermal model of Gen 1 (Fig #1).

$$T_X = \frac{(R_{THJC} \times T_{PCB} + R_{THJB} \times T_{CASE})}{(R_{THJC} + R_{THJB})}$$

Equation #1:

Equivalent single branch environmental temperature

Using electrical analogy (Equation #1), mathematical solutions to this problem are simple. By solving for open circuit voltage and short circuit current at T_J , the equivalent single branch thermal resistance (R_{THJX}) and equivalent single branch environmental temperature (T_X) can easily be computed. The resulting equivalent thermal resistance (R_{THJX}) is the simple parallel equivalent of R_{THJB} & R_{THJC} (Equation #2). Since R_{THJB} & R_{THJC} are fixed at design time, they are easily incorporated into the SOA graphical solution.

Unfortunately, solving for T_X at design time is im-

possible because it is dependent on PCB temperature (T_{PCB}) and case temperature (T_{CASE}),

$$R_{THJX} = \frac{R_{THJC} \times R_{THJB}}{R_{THJC} + R_{THJB}}$$

Equation #2:

Equivalent single branch thermal resistance

which will vary from application-to-application. Fortunately, this simple equation can be solved in graphical form by adding two additional x-axes, T_{CASE} and T_X , to the SOA graph (Fig #3). Several aspects of this equation are evident on inspection:

- All effects are divided by $R_{THJC} + R_{THJB}$
 - As R_{THJB} increases, T_{CASE} becomes more dominant
 - As R_{THJC} increases, T_{PCB} becomes more dominant
- These three effects are readily incorporated into a graph by observing the following:
- Total distance from T_{CASE} axis to T_{PCB} axis proportional to $R_{THJB} + R_{THJC}$
 - Distance from the T_{PCB} axis to the T_X axis proportional to R_{THJB}

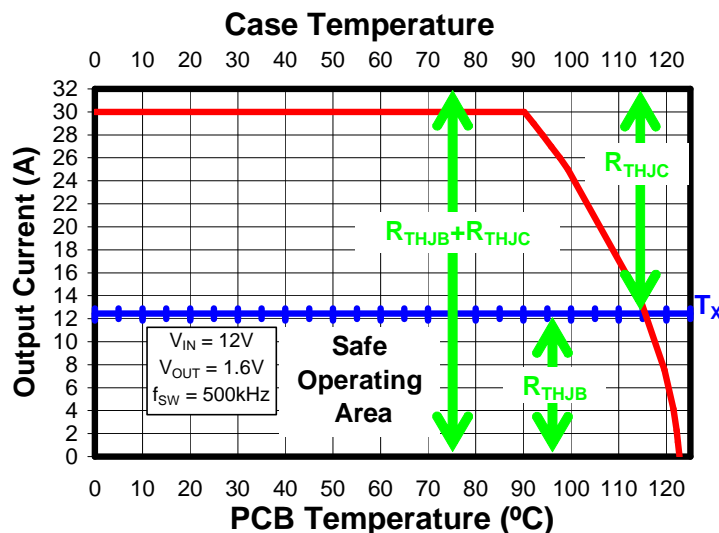

Fig #3: SOA graph showing thermal resistance proportions

90°C and the case temperature is 110°C. T_X axis intercept is at 97.5°C, and the resulting SOA is about 25.5A under these conditions. It is not important to note the T_X axis intercept temperature, only to accurately draw the solution lines from that point.

If the top of the case is not attached to a heatsink, then set T_{CASE} to 125°C in order to find the maximum SOA.

Procedure for determining SOA

- 1 Draw a line from T_{CASE} axis at T_{CASE} , to the T_{PCB} axis at T_{PCB} .
- 2 Draw a vertical line from the T_X axis intercept, to the SOA curve.
- 3 Draw a horizontal line from the intersection of the vertical line with the SOA curve, to the Y axis.
- 4 The point at which the horizontal line meets the y-axis is the SOA current.

Deriving the SOA curve

While it is transparent to the user, it may be useful to understand how it is derived.

The objective is to keep the hottest semiconductor in the module to at or safe below its maximum

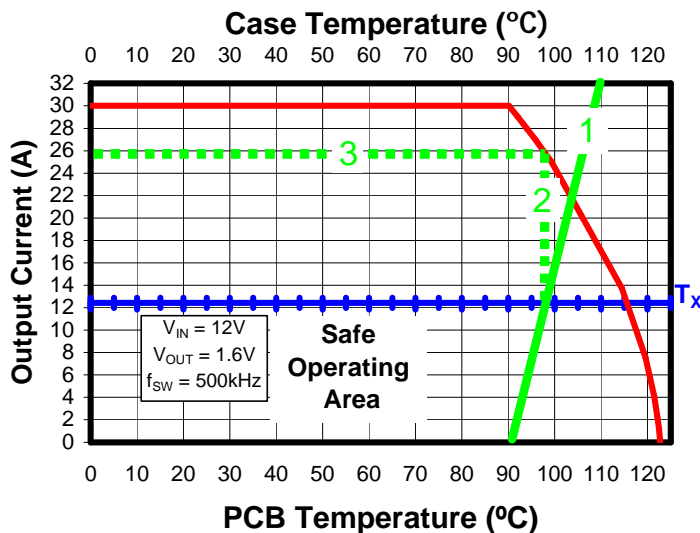

Fig #4: SOA graph with typical solution

- Distance from the T_{CASE} axis to the T_X axis proportional to R_{THJC}

Example Solution

In the example of Figure #4, PCB temperature is

specified junction temperature.

The power MOSFETs are always the hottest components. While they are quite capable of operating reliably to 175°C, in the case of current iPOWIR products that maximum junction temperature is limited to 125°C to facilitate an extremely robust product.

Equation #3 satisfies that simple relationship

$$T_X = \text{MAX}_{T_J} - R_{THJX} \times PD_{(IRMS)}$$

Equation #3:

Solving for T_X on the SOA curve

where $PD_{(IRMS)}$ is the module power dissipation at a particular RMS current when the internal module temperature is MAX_{T_J} .

For all iPOWIR products, IRMS has been truncated to the value which can be achieved at T_X of 90°C so that the ratings are very practical to use.