

$I_{F(AV)} = 20\text{Amp}$
 $V_R = 80/100\text{V}$

Major Ratings and Characteristics

Characteristics	Values	Units
$I_{F(AV)}$ Rectangular waveform (Per Device)	20	A
I_{FRM} @ $T_C = 133^\circ\text{C}$ (Per Leg)	20	A
V_{RRM}	80/ 100	V
I_{FSM} @ $tp = 5 \mu\text{s}$ sine	850	A
V_F @ $10\text{Apk}, T_J = 125^\circ\text{C}$	0.70	V
T_J range	-65 to 150	$^\circ\text{C}$

Description/ Features

This center tap Schottky rectifier has been optimized for low reverse leakage at high temperature. The proprietary barrier technology allows for reliable operation up to 150°C junction temperature. Typical applications are in switching power supplies, converters, free-wheeling diodes, and reverse battery protection.

- 150°C T_J operation
- Center tap TO-220, D²Pak and TO-262 packages
- Low forward voltage drop
- High purity, high temperature epoxy encapsulation for enhanced mechanical strength and moisture resistance
- High frequency operation
- Guard ring for enhanced ruggedness and long term reliability
- Lead-Free ("PbF" suffix)

Case Styles

MBR20...CTPbF



TO-220

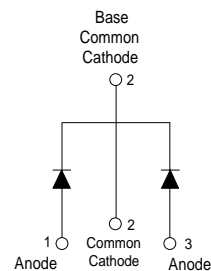

Voltage Ratings

Parameters	MBR2080CTPbF	MBR2090CTPbF	MBR20100CTPbF
V _R Max. DC Reverse Voltage (V)	80	90	100
V _{RWM} Max. Working Peak Reverse Voltage (V)			

Absolute Maximum Ratings

Parameters	Values	Units	Conditions
I _{F(AV)} Max. Average Forward Current (Per Leg) (Per Device)	10	A	@ T _C = 133°C, (Rated V _R)
	20		
I _{FRM} Peak Repetitive Forward Current (Per Leg)	20	A	Rated V _R , square wave, 20kHz T _C = 133°C
I _{FSM} Non Repetitive Peak Surge Current	850	A	5µs Sine or 3µs Rect. pulse Following any rated load condition and with rated V _R applied Surge applied at rated load conditions halfwave, single phase, 60Hz
	150		
I _R RM Peak Repetitive Reverse Surge Current	0.5	A	2.0 µsec 1.0 KHz
E _{AS} Non-Repetitive Avalanche Energy (Per Leg)	24	mJ	T _J = 25°C, I _{AS} = 2 Amps, L = 12 mH

Electrical Specifications

Parameters	Values	Units	Conditions
V _{FM} Max. Forward Voltage Drop (1)	0.80	V	@ 10A T _J = 25°C
	0.95	V	@ 20A
	0.70	V	@ 10A T _J = 125°C
	0.85	V	@ 20A
I _{RM} Max. Instantaneous Reverse Current (1)	0.10	mA	T _J = 25°C
	6	mA	T _J = 125°C
V _{F(TO)} Threshold Voltage	0.433	V	T _J = T _J max.
r _t Forward Slope Resistance	15.8	mΩ	
C _T Max. Junction Capacitance	400	pF	V _R = 5V _{DC} (test signal range 100Khz to 1Mhz) 25°C
L _S Typical Series Inductance	8.0	nH	Measured from top of terminal to mounting plane
dv/dt Max. Voltage Rate of Change (Rated V _R)	10000	V/µs	

Thermal-Mechanical Specifications

(1) Pulse Width < 300µs, Duty Cycle <2%

Parameters	Values	Units	Conditions
T _J Max. Junction Temperature Range	-65 to 150	°C	
T _{stg} Max. Storage Temperature Range	-65 to 175	°C	
R _{thJC} Max. Thermal Resistance Junction to Case (Per Leg)	2.0	°C/W	DC operation
R _{thCS} Typical Thermal Resistance Case to Heatsink	0.50	°C/W	Mounting surface, smooth and greased Only for TO-220
R _{thJA} Max. Thermal Resistance Junction to Ambient	50	°C/W	DC operation For D2Pak and TO-262
wt Approximate Weight	2 (0.07)	g (oz.)	
T Mounting Torque	Min.	6 (5)	Non-lubricated threads
	Max.	12 (10)	
Marking Device	MBR20100CT		

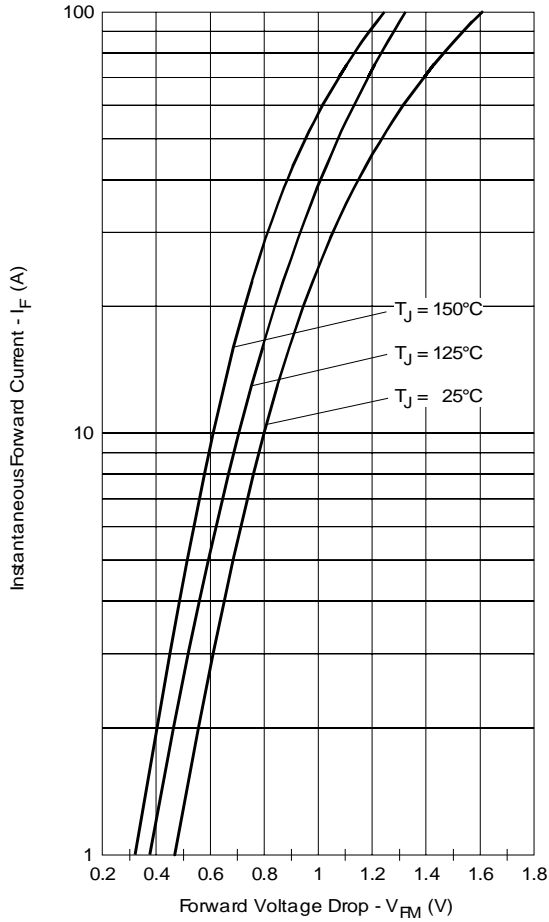

Fig. 1 - Max. Forward Voltage Drop Characteristics (Per Leg)

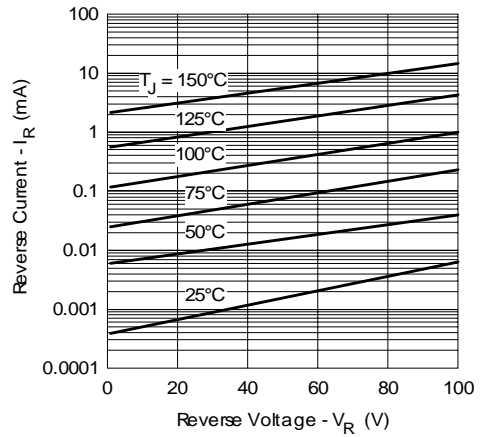

Fig. 2 - Typical Values Of Reverse Current Vs. Reverse Voltage (Per Leg)

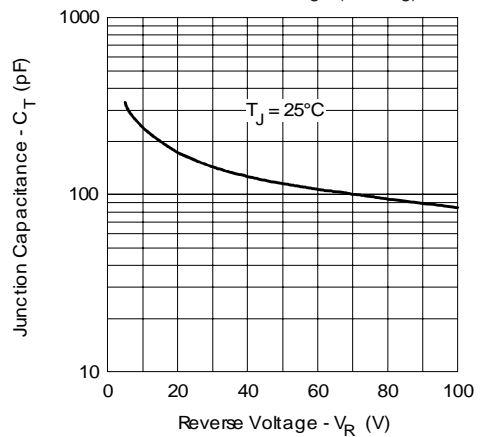

Fig. 3 - Typical Junction Capacitance Vs. Reverse Voltage (Per Leg)

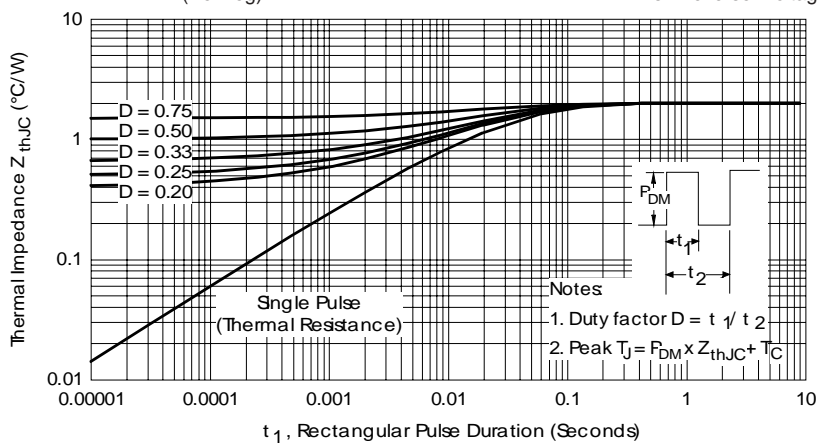

Fig. 4 - Max. Thermal Impedance Z_{thJC} Characteristics (Per Leg)

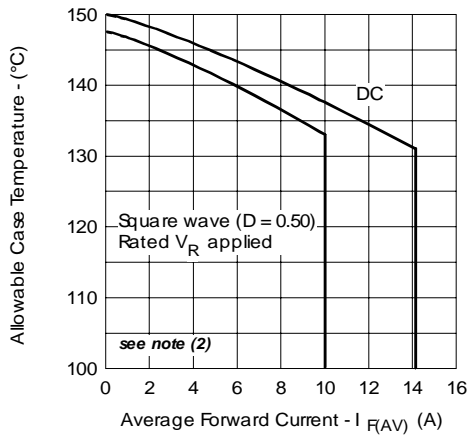

Fig. 5 - Max. Allowable Case Temperature Vs. Average Forward Current (Per Leg)

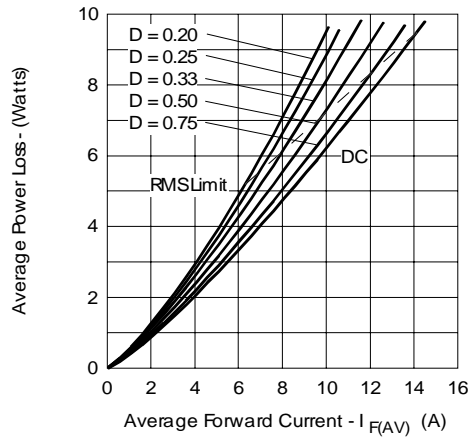

Fig. 6 - Forward Power Loss Characteristics (Per Leg)

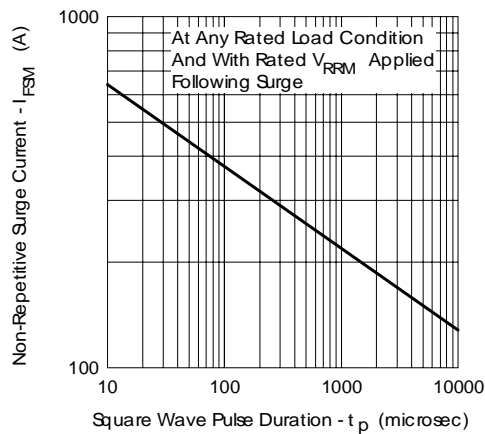
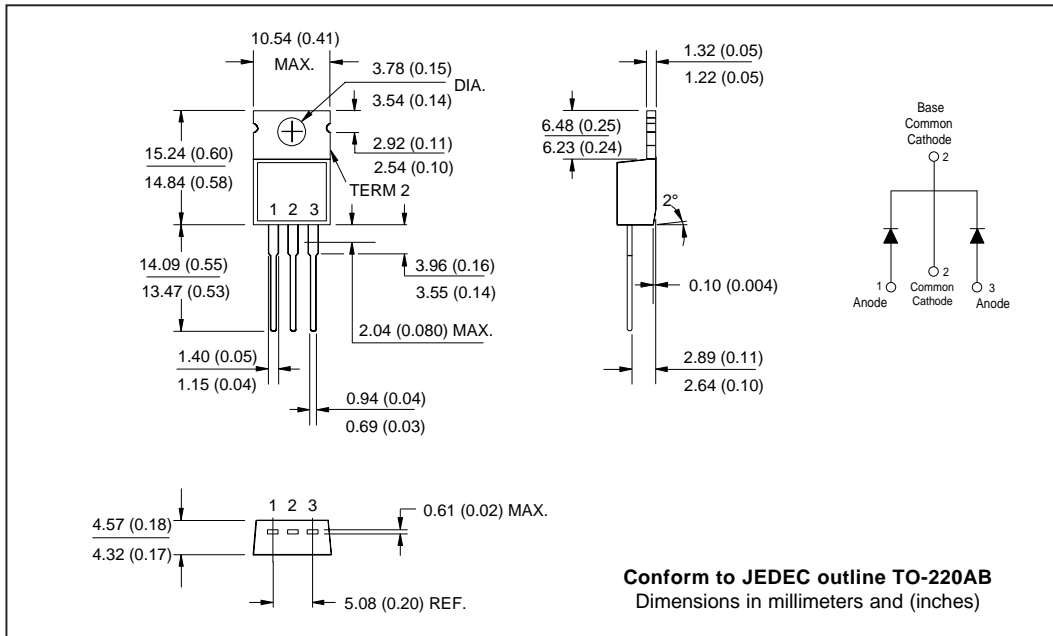

Fig. 7 - Max. Non-Repetitive Surge Current (Per Leg)

- (2) Formula used: $T_c = T_j - (Pd + Pd_{REV}) \times R_{thJC}$;
 $Pd = \text{Forward Power Loss} = I_{F(AV)} \times V_{FM} @ (I_{F(AV)} / D)$ (see Fig. 6);
 $Pd_{REV} = \text{Inverse Power Loss} = V_{R1} \times I_R (1 - D)$; $I_R @ V_{R1} = \text{rated } V_R$

Outline Table



Part Marking Information

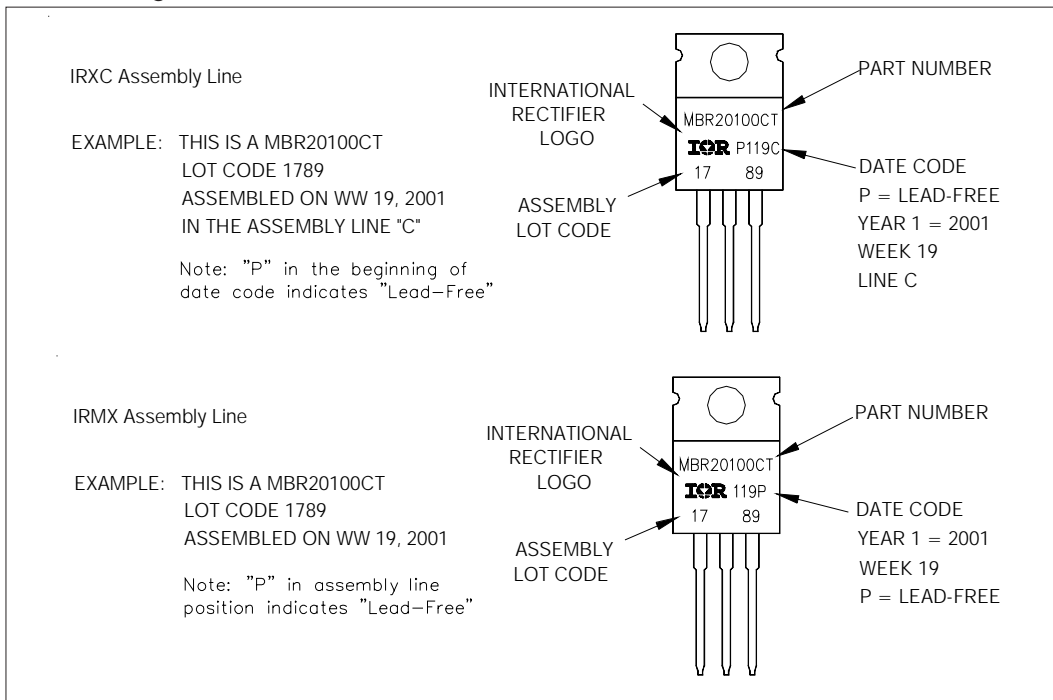

Ordering Information Table

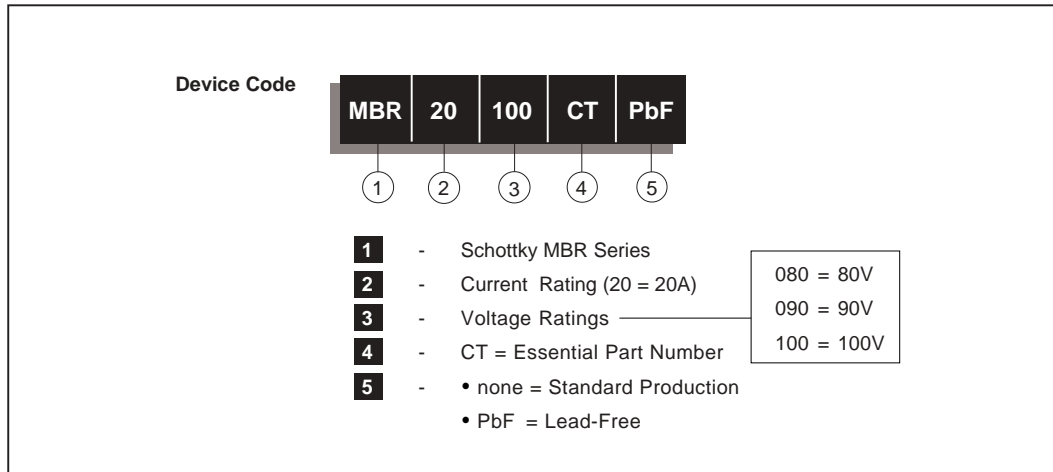

Data and specifications subject to change without notice.
 This product has been designed and qualified for Industrial Level and Lead-Free.
 Qualification Standards can be found on IR's Web site.