

DUAL LOW SIDE DRIVER

Features

- Gate drive supply range from 6 V to 20 V
- CMOS Schmitt-triggered inputs
- Matched propagation delay for both channels
- Outputs out of phase with inputs (IRS4426)
- Outputs in phase with inputs (IRS4427)
- OutputA out of phase with inputA and outputB in phase with inputB (IRS4428)
- RoHS compliant

Descriptions

The IRS4426/IRS4427/IRS4428 are low voltage, high speed power MOSFET and IGBT driver. Proprietary latch immune CMOS technologies enable ruggedized monolithic construction. Logic inputs are compatible with standard CMOS or LSTTL outputs. The output drivers feature a high pulse current buffer stage designed for minimum driver cross-conduction. Propagation delays between two channels are matched.

Product Summary

$I_{O+/-}$	1.5 A / 1.5 A
V_{OUT}	6 V - 20 V
$t_{on/off}$ (typ.)	50 ns & 50 ns

Packages



8 Lead PDIP



8-Lead SOIC

Block Diagram

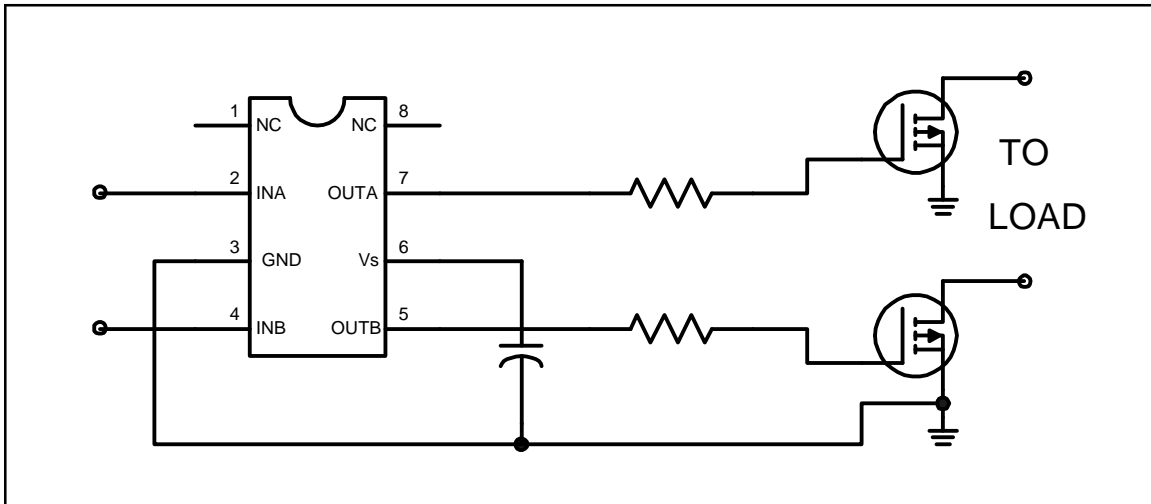

Absolute Maximum Ratings

Absolute maximum ratings indicate sustained limits beyond which damage to the device may occur. All voltage parameters are absolute voltages referenced to GND. The thermal resistance and power dissipation ratings are measured under board mounted and still air conditions.

Symbol	Definition	Min.	Max.	Units	
V _S	Fixed supply voltage	-0.3	20 (Note 1)	V	
V _O	Output voltage	-0.3	V _S + 0.3		
V _{IN}	Logic input voltage	-0.3	V _S + 0.3		
P _D	Package power dissipation @ T _A ≤ +25 °C	(8 Lead PDIP)	—	1.0	W
		(8 lead SOIC)	—	0.625	
R _{thJA}	Thermal resistance, junction to ambient	(8 lead PDIP)	—	125	°C/W
		(8 lead SOIC)	—	200	
T _J	Junction temperature	—	150	°C	
T _S	Storage temperature	-55	150		
T _L	Lead temperature (soldering, 10 seconds)	—	300		

Note 1: All supplies are fully tested at 25 V and an internal 20 V clamp exists for each supply.

Recommended Operating Conditions

The input/output logic timing diagram is shown in Fig. 1. For proper operation the device should be used within the recommended conditions. All voltage parameters are absolute voltages referenced to GND.

Symbol	Definition	Min.	Max.	Units
V _S	Fixed supply voltage	6	20	V
V _O	Output voltage	0	V _S	
V _{IN}	Logic input voltage	0	V _S	
T _A	Ambient temperature	-40	125	°C

DC Electrical Characteristics

V_{BIAS} (V_S) = 15 V, T_A = 25 °C unless otherwise specified. The V_{IN} and I_{IN} parameters are referenced to GND and are applicable to input leads: INA and INB. The V_O and I_O parameters are referenced to GND and are applicable to the output leads: OUTA and OUTB.

Symbol	Definition	Min.	Typ.	Max.	Units	Test Conditions
V _{IH}	Logic "0" input voltage (OUTA=LO, OUTB=LO) (IRS4426)	2.5	—	—	V	
	Logic "1" input voltage (OUTA=HI, OUTB=HI) (IRS4427)					
	Logic "0" input voltage (OUTA=LO), Logic "1" input voltage (OUTB=HI) (IRS4428)					

DC Electrical Characteristics cont.

V_{BIAS} (V_S) = 15 V, T_A = 25 °C unless otherwise specified. The V_{IN} , and I_{IN} parameters are referenced to GND and are applicable to input leads: INA and INB. The V_O and I_O parameters are referenced to GND and are applicable to the output leads: OUTA and OUTB.

Symbol	Definition	Min.	Typ.	Max.	Units	Test Conditions
V_{IL}	Logic "1" input voltage (OUTA=HI, OUTB=HI) (IRS4426)	—	—	0.6	V	
	Logic "0" input voltage (OUTA=LO, OUTB=LO) (IRS4427)					
	Logic "1" input voltage (OUTA=HI), Logic "0" input voltage (OUTB=LO) (IRS4428)					
V_{OH}	High level output voltage, $V_{BIAS}-V_O$	—	—	1.4		$I_O = 0$ A
V_{OL}	Low level output voltage, V_O	—	—	0.15		$I_O = 20$ mA
I_{IN+}	Logic "1" input bias current (OUT=HI)	—	5	15	μ A	$V_{IN} = 0$ V (IRS4426) $V_{IN} = V_S$ (IRS4427) $V_{INA} = 0$ V (IRS4428) $V_{INB} = V_S$ (IRS4428)
I_{IN-}	Logic "0" input bias current (OUT=LO)	—	-10	-30		$V_{IN} = V_S$ (IRS4426) $V_{IN} = 0$ V (IRS4427) $V_{INA} = V_S$ (IRS4428) $V_{INB} = 0$ V (IRS4428)
I_{QS}	Quiescent V_S supply current	—	100	200		$V_{IN} = 0$ V or V_S
I_{O+}	Output high short circuit pulsed current	---	2.3	—	A	$V_O = 0$ V, $V_{IN} = 0$ V (IRS4426) $V_O = 0$ V, $V_{IN} = V_S$ (IRS4427) $V_O = 0$ V, $V_{INA} = 0$ V (IRS4428) $V_O = 0$ V, $V_{INB} = V_S$ (IRS4428) $PW \leq 10$ μ s
I_{O-}	Output low short circuit pulsed current	---	3.3	—		$V_O = 15$ V, $V_{IN} = V_S$ (IRS4426) $V_O = 15$ V, $V_{IN} = 0$ V (IRS4427) $V_O = 15$ V, $V_{INA} = V_S$ (IRS4428) $V_O = 15$ V, $V_{INB} = 0$ V (IRS4428) $PW \leq 10$ μ s

AC Electrical Characteristics

$V_{BIAS} (V_S) = 15\text{ V}$, $C_L = 1000\text{ pF}$, $T_A = 25\text{ }^\circ\text{C}$ unless otherwise specified.

Symbol	Definition	Min.	Typ.	Max.	Units	Test Conditions
Propagation delay characteristics						
t_{d1}	Turn-on propagation delay	—	50	95	ns	Fig. 4
t_{d2}	Turn-off propagation delay	—	50	95		
t_r	Turn-on rise time	—	25	55		
t_f	Turn-off fall time	—	25	55		

Functional Block Diagram IRS4426

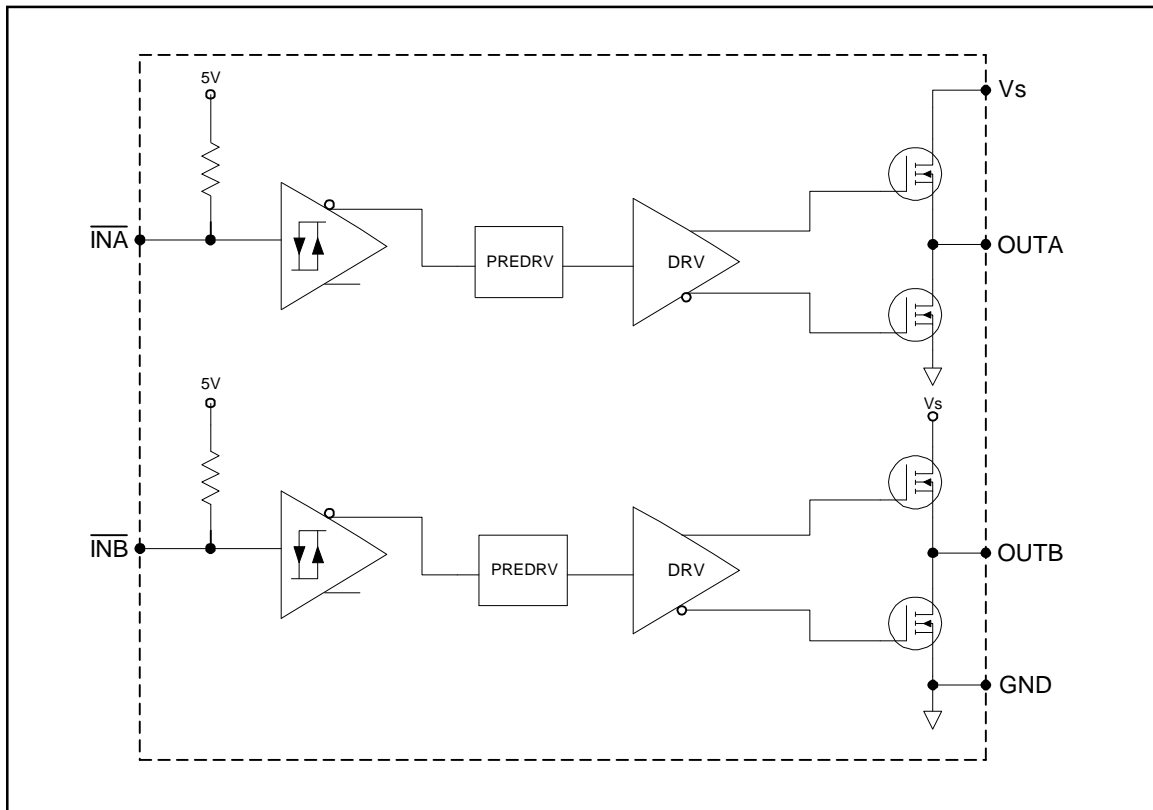

Functional Block Diagram IRS4427

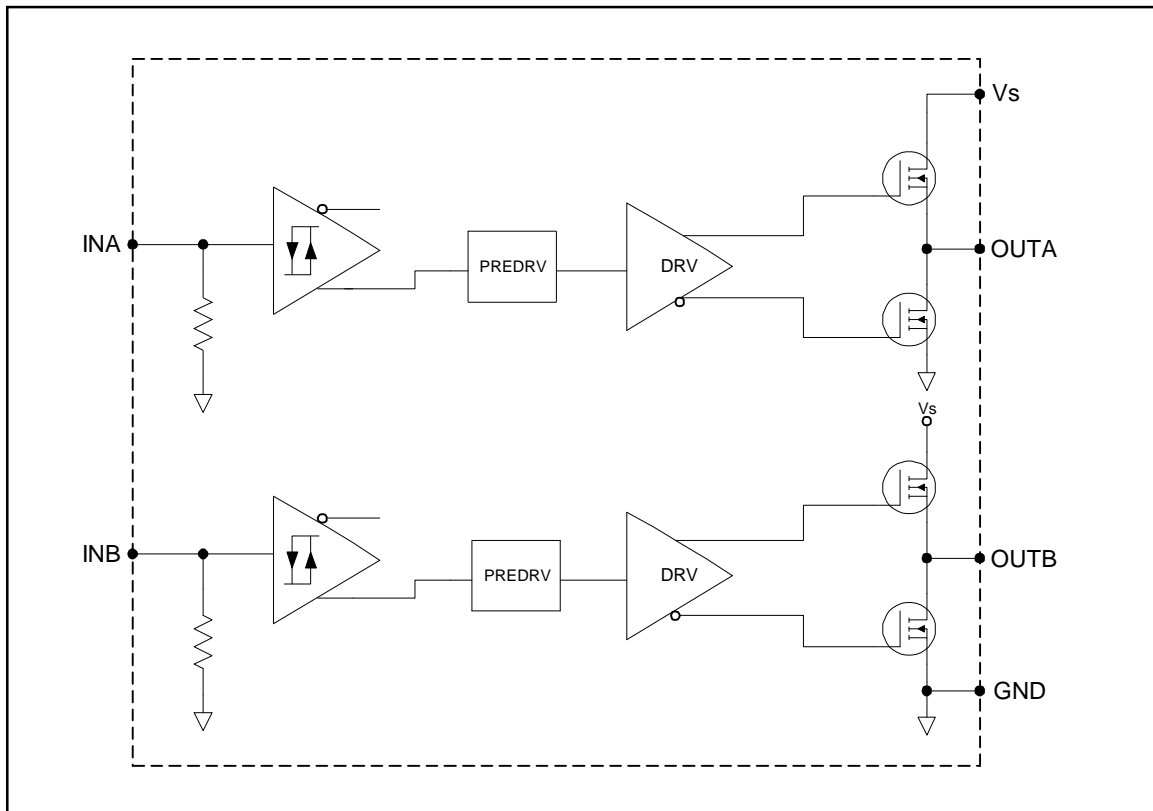

Functional Block Diagram IRS4428

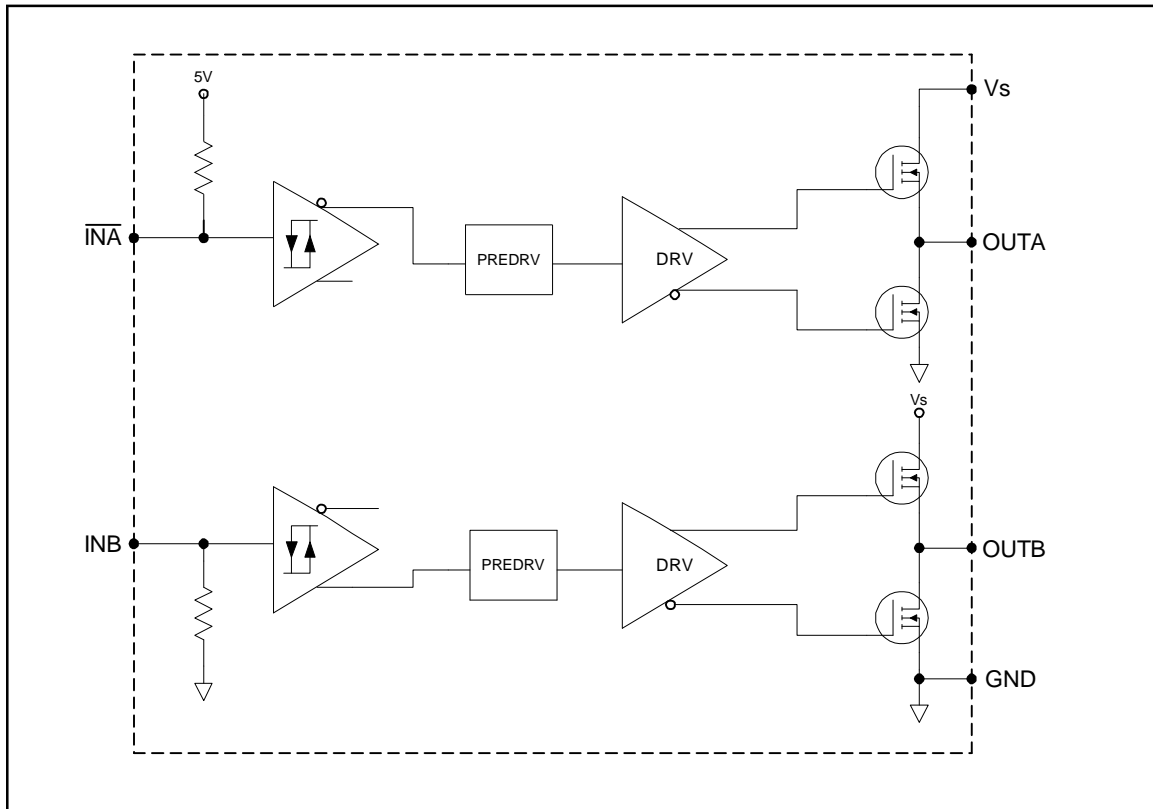

Lead Definitions

Symbol	Description
Vs	Supply voltage
GND	Ground
INA	Logic input for gate driver output (OUTA), out of phase (IRS4426, IRS4428), in phase (IRS4427)
INB	Logic input for gate driver output (OUTB), out of phase (IRS4426), in phase (IRS4427, IRS4428)
OUTA	Gate drive output A
OUTB	Gate drive output B

Lead Assignments

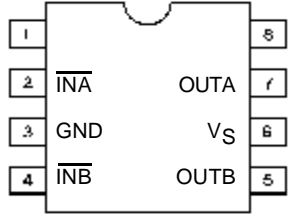
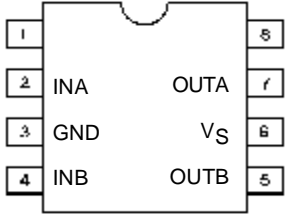
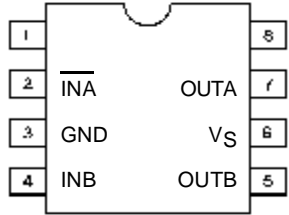
 <p>8 Lead PDIP</p>	 <p>8 Lead PDIP</p>	 <p>8 Lead PDIP</p>
IRS4426	IRS4427	IRS4428
Part Number		

Lead Assignments

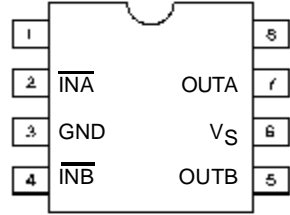
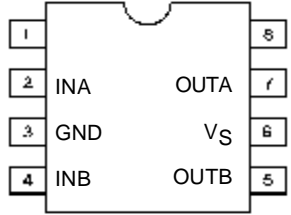
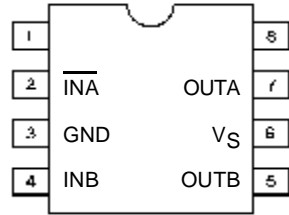
 <p>8 Lead SOIC</p>	 <p>8 Lead SOIC</p>	 <p>8 Lead SOIC</p>
IRS4426S	IRS4427S	IRS4428S
Part Number		

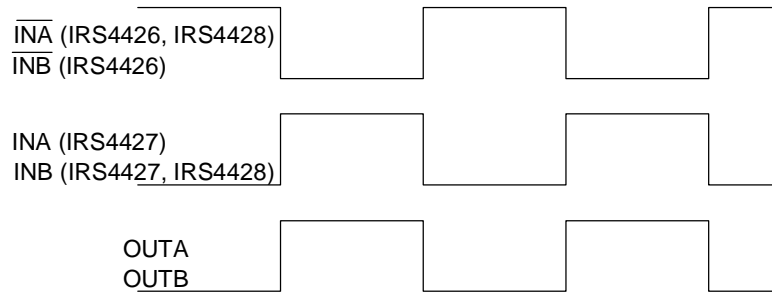

Figure 1. Timing Diagram

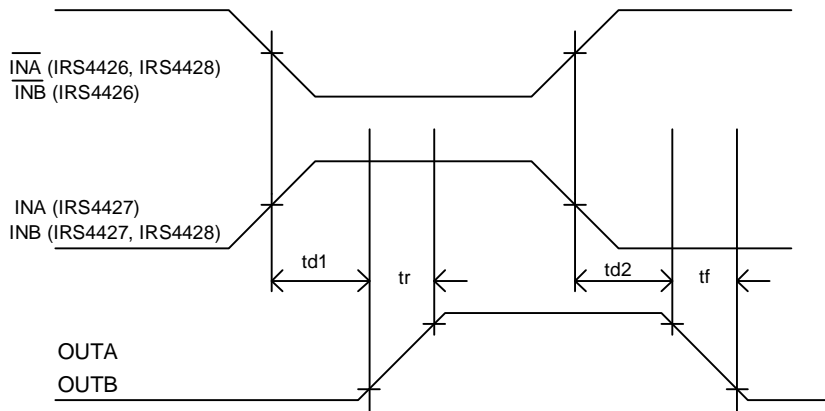

Figure 2. Switching Time Waveforms

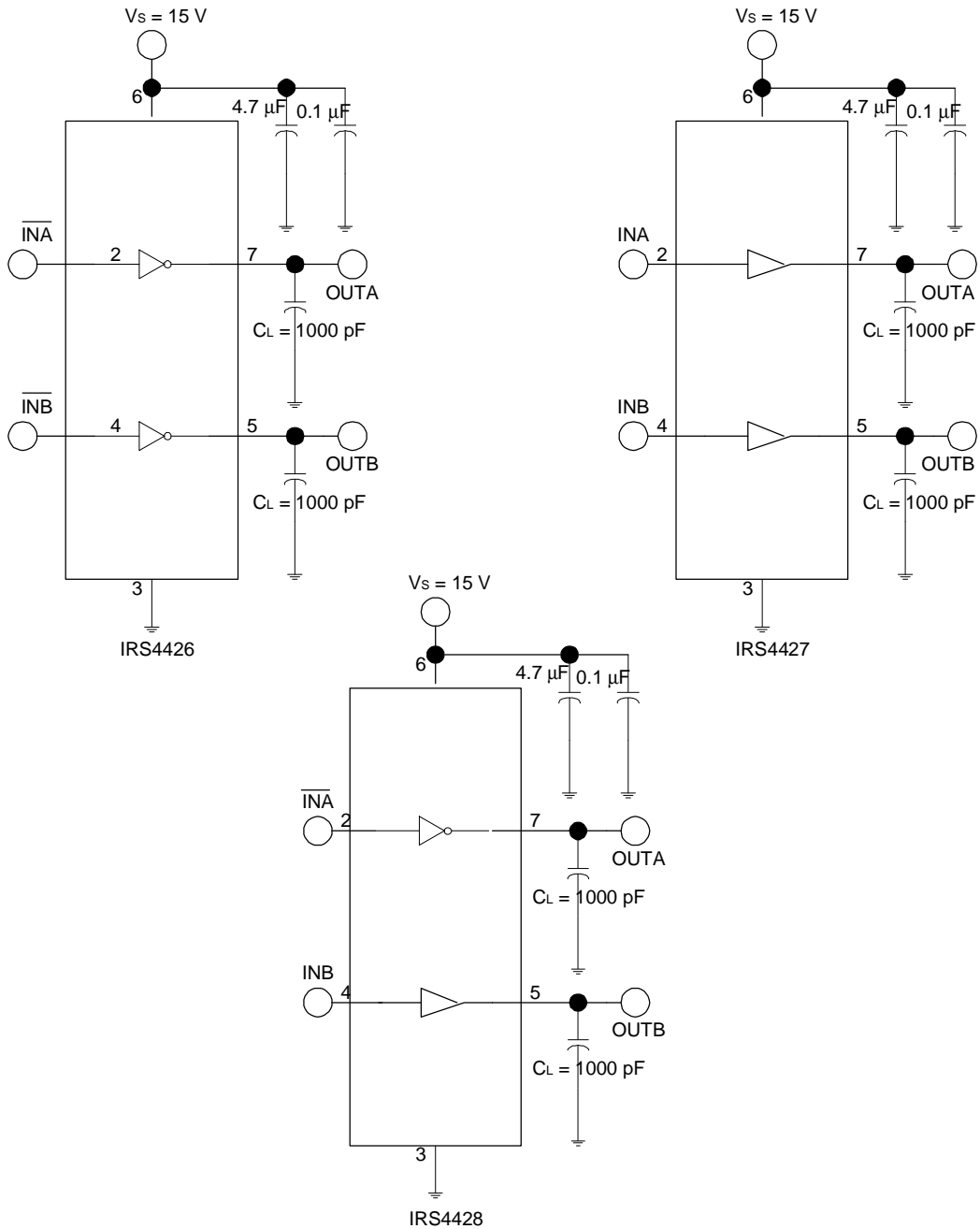

Figure 3. Switching Time Test Circuits

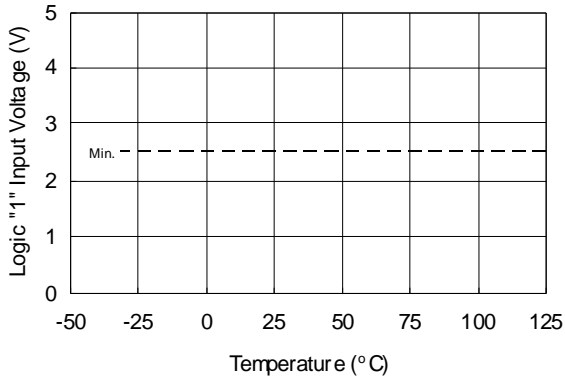

Figure 4A. Logic "1" Input Voltage vs. Temperature

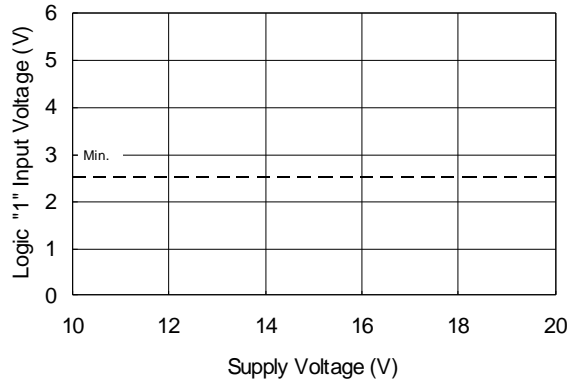

Figure 4B. Logic "1" Input Voltage vs. Supply Voltage

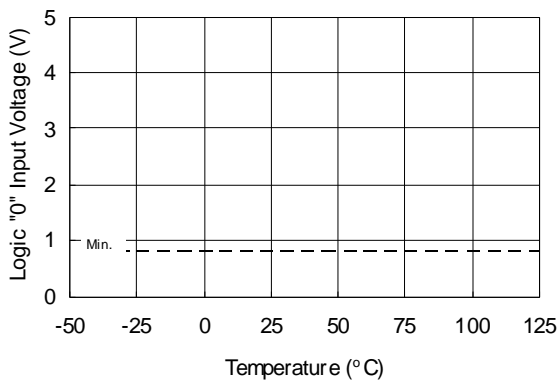

Figure 5A. Logic "0" Input Voltage vs. Temperature

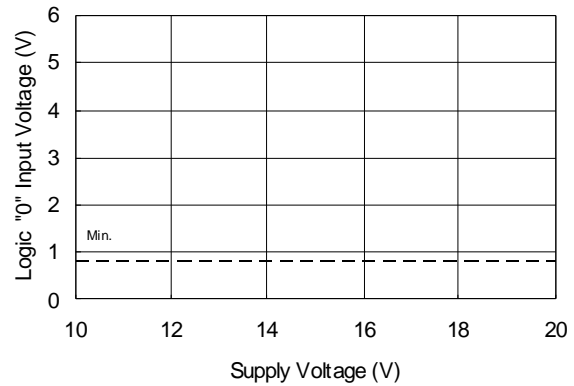

Figure 5B. Logic "0" Input Voltage vs. Supply Voltage

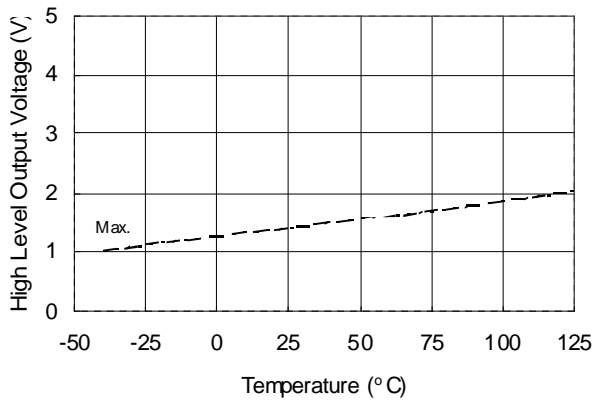

Figure 6A. High Level Output Voltage vs. Temperature (I_O = 0 mA)

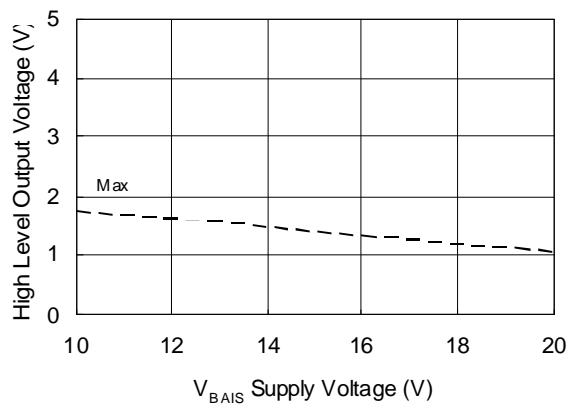

Figure 6B. High Level Output Voltage vs. Supply Voltage (I_O = 0 mA)

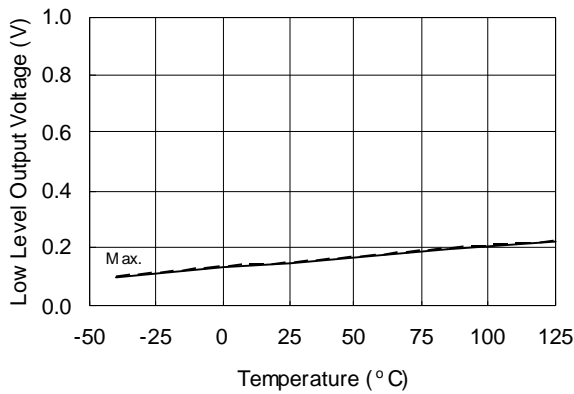

Figure 7A. Low Level Output Voltage vs. Temperature (I_O = 20 mA)

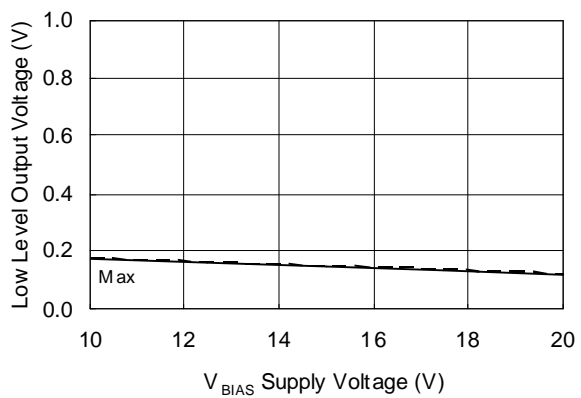

Figure 7B. Low Level Output vs. Supply Voltage (I_O = 20 mA)

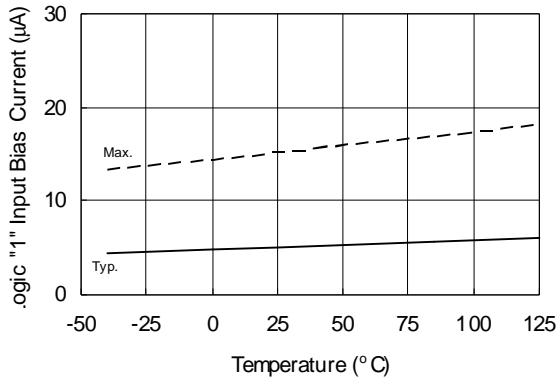

Figure 8A. Logic "1" Input Bias Current vs. Temperature

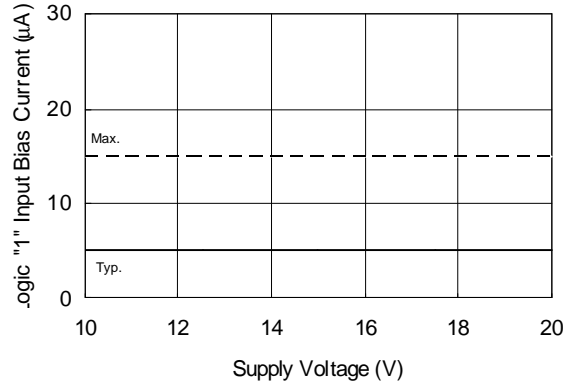

Figure 8B. Logic "1" Input Bias Current vs. Supply Voltage

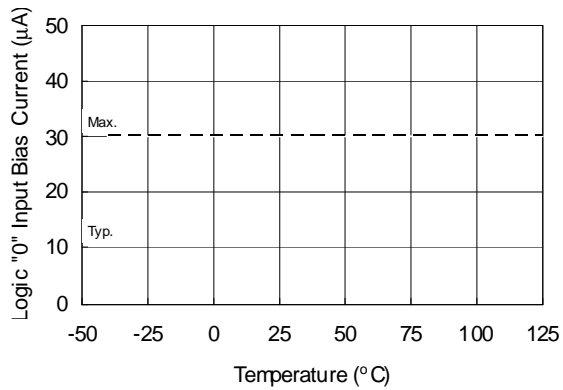

Figure 9A. Logic "0" Input Bias Current vs. Temperature

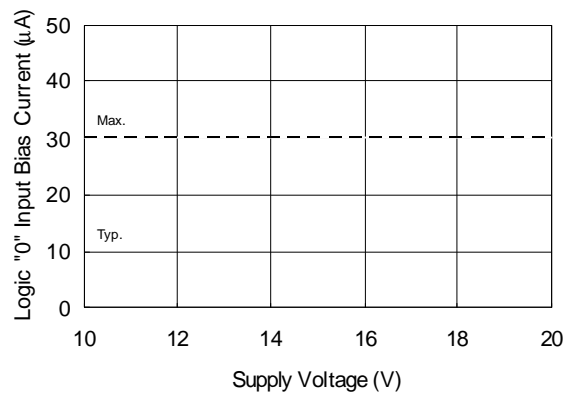

Figure 9B. Logic "0" Input Bias Current vs. Supply Voltage

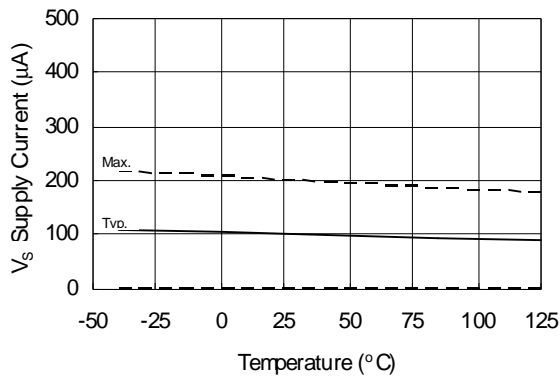

Figure 10A. V_s Supply Current vs. Temperature

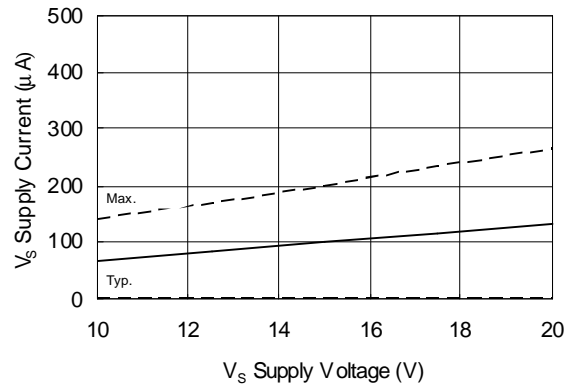

Figure 10B. V_s Supply Current vs. V_s Supply Voltage

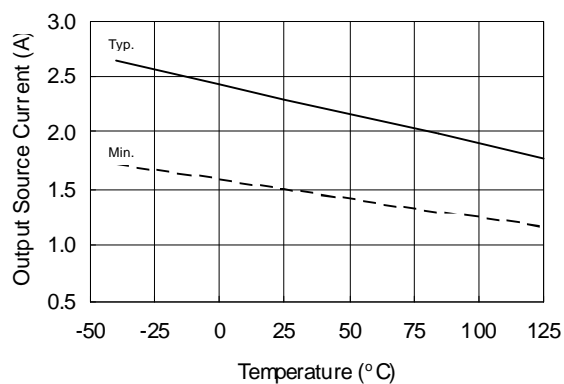

Figure 11A. Output Source Current vs. Temperature

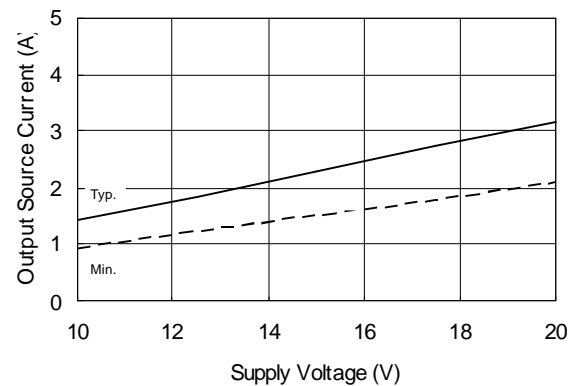

Figure 11B. Output Source Current vs. Supply Voltage

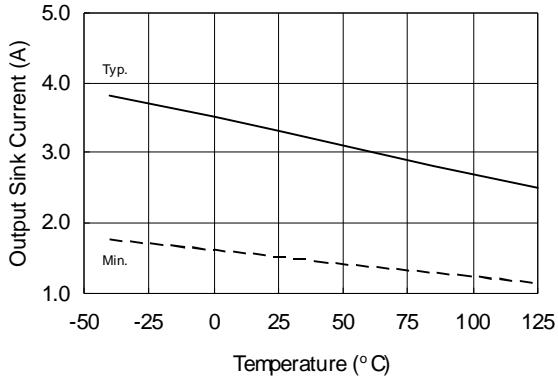

Figure 12A. Output Sink Current vs. Temperature

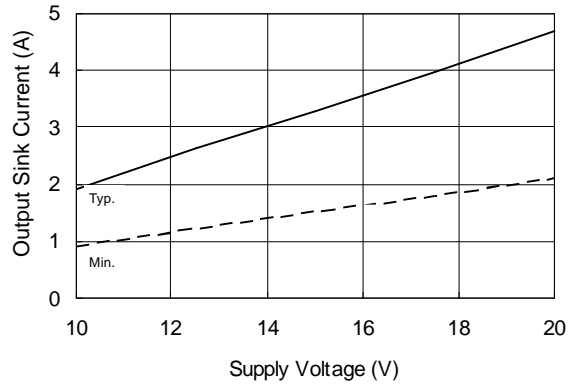

Figure 12B. Output Sink Current vs. Supply Voltage

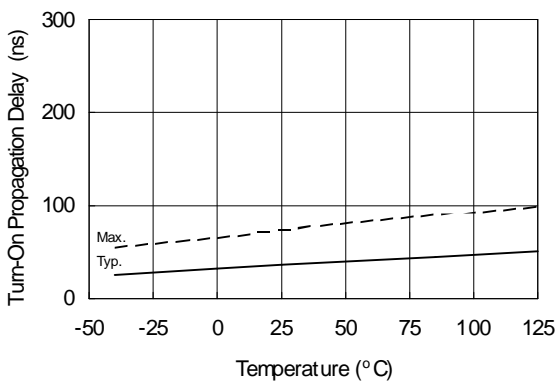

Figure 13A. Turn-On Propagation Delay vs. Temperature

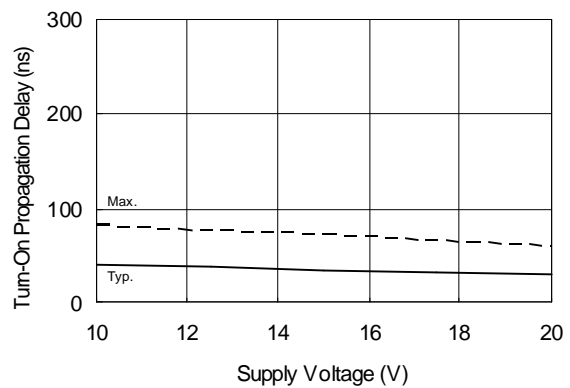

Figure 13B. Turn-On Propagation Delay vs. Supply Voltage

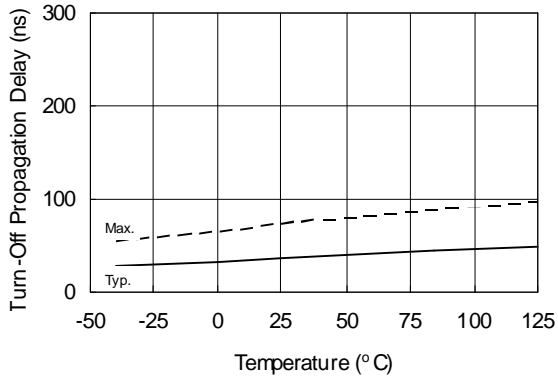

Figure 14A. Turn-Off Propagation Delay vs. Temperature

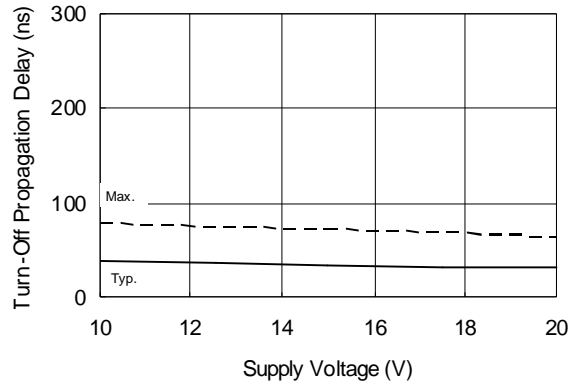

Figure 14B. Turn-Off Propagation Delay vs. Supply Voltage

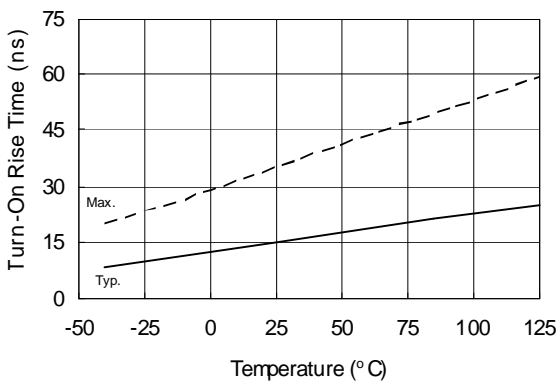

Figure 15A. Turn-On Rise Time vs. Temperature

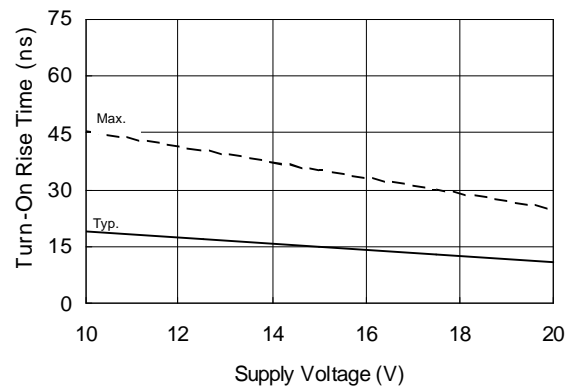

Figure 15B. Turn-On Rise Time vs. Supply Voltage

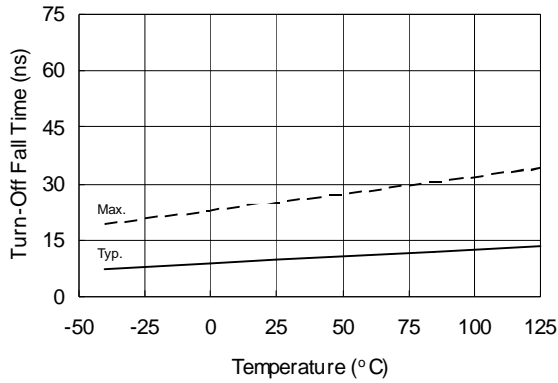

Figure 16A. Turn-Off Fall Time vs. Temperature

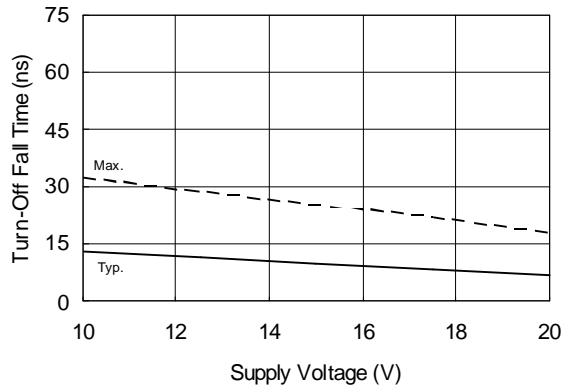
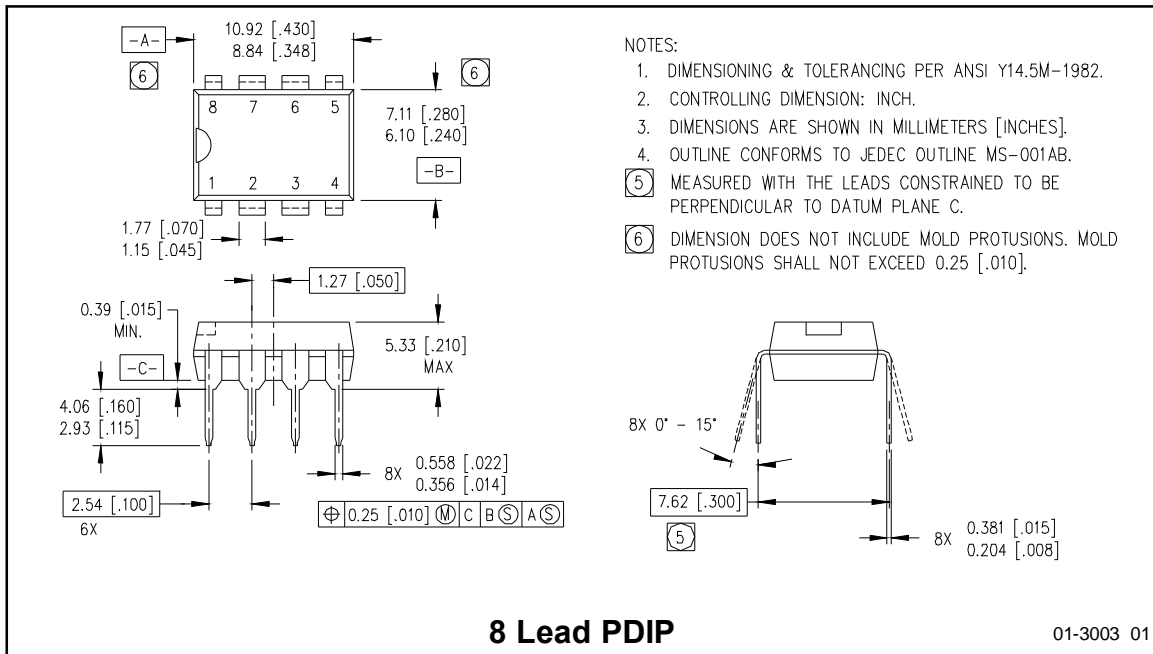
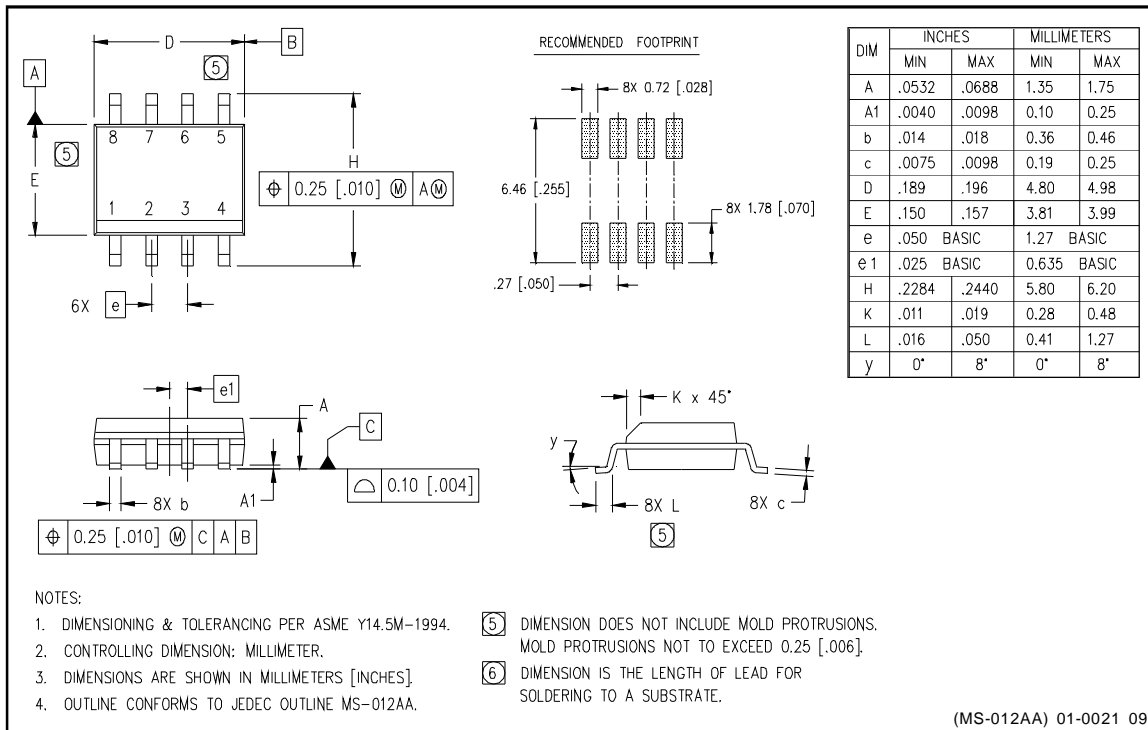

Figure 16B. Turn-Off Fall Time vs. Supply Voltage

Caseoutline



Case Outline - 8 Lead SOIC



IRS4426/IRS4427/IRS4428(S)PbF

Tape & Reel 8-lead SOIC

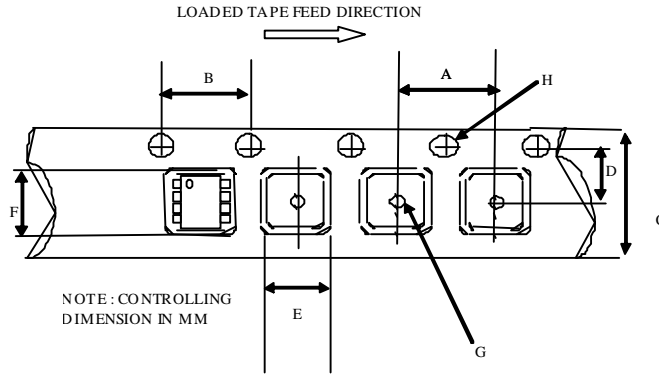

CARRIER TAPE DIMENSION FOR 8SOICN

Code	Metric		Imperial	
	Min	Max	Min	Max
A	7.90	8.10	0.311	0.318
B	3.90	4.10	0.153	0.161
C	11.70	12.30	0.46	0.484
D	5.45	5.55	0.214	0.218
E	6.30	6.50	0.248	0.255
F	5.10	5.30	0.200	0.208
G	1.50	n/a	0.059	n/a
H	1.50	1.60	0.059	0.062

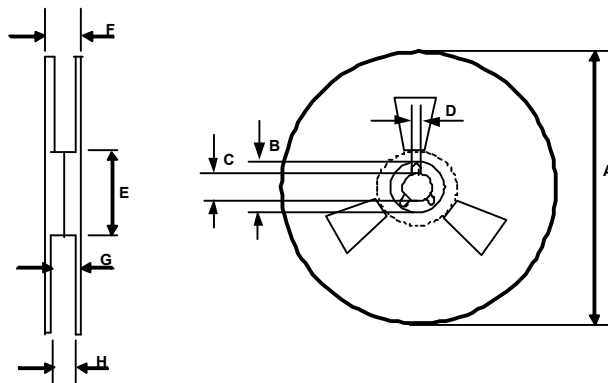

REEL DIMENSIONS FOR 8SOICN

Code	Metric		Imperial	
	Min	Max	Min	Max
A	329.60	330.25	12.976	13.001
B	20.95	21.45	0.824	0.844
C	12.80	13.20	0.503	0.519
D	1.95	2.45	0.767	0.096
E	98.00	102.00	3.858	4.015
F	n/a	18.40	n/a	0.724
G	14.50	17.10	0.570	0.673
H	12.40	14.40	0.488	0.566

LEADFREE PART MARKING INFORMATION

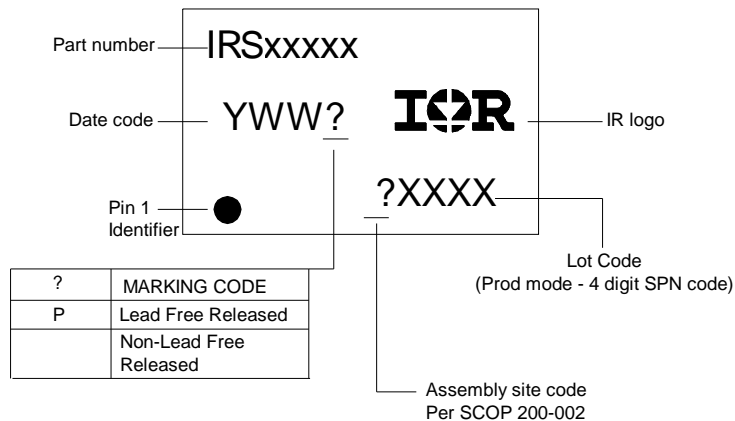

ORDER INFORMATION

- 8-Lead PDIP IRS4426PbF
- 8-Lead SOIC IRS4426SPbF
- 8-Lead PDIP IRS4427PbF
- 8-Lead SOIC IRS4427SPbF
- 8-Lead PDIP IRS4428PbF
- 8-Lead SOIC IRS4428SPbF