

**3-PHASE BRIDGE DRIVER**

**Features**

- Floating channel designed for bootstrap operation
- Fully operational to +600 V
- Tolerant to negative transient voltage, dV/dt immune
- Gate drive supply range from 10 V /12 V to 20 V DC and up to 25 V for transient
- Undervoltage lockout for all channels
- Over-current shutdown turns off all six drivers
- Three Independent half-bridge drivers
- Matched propagation delay for all channels
- 2.5 V logic compatible
- Outputs out of phase with inputs
- All parts are LEAD-FREE

**Product Summary**

$V_{\text{OFFSET}}$	600 V max.
$I_{\text{O}+/-}$ (min.)	200 mA / 420 mA
$V_{\text{OUT}}$	10 V – 20 V or 12 – 20 V
$t_{\text{on/off}}$ (typ.)	500 ns
Deadtime (typ.)	230 ns

**Applications:**

- \*Motor Control
- \*Air Conditioners/ Washing Machines
- \*General Purpose Inverters
- \*Micro/Mini Inverter Drives

**Description**

The IRS213(3, 5) are high voltage, high speed power MOSFET and IGBT drivers with three independent high and low side referenced output channels for 3-phase applications. Proprietary HVIC technology enables ruggedized monolithic construction. Logic inputs are compatible with CMOS or LSTTL outputs, down to 2.5 V logic. An independent operational amplifier provides analog feedback of bridge current via an external current sense resistor. A current trip function which terminates all six outputs can also derived from this resistor. A shutdown function is available to terminate all six outputs. An open drain FAULT signal is provided to indicate that an over-current or undervoltage shutdown has occurred. Fault conditions are cleared with the FLT-CLR lead. The output drivers feature a high pulse current buffer stage designed for minimum driver cross-conduction. Propagation delays are matched to simplify use in high frequencies applications. The floating channels can be used to drive N-channel power MOSFETs or IGBTs in the high side configuration which operates up to 600 V.

**Packages**

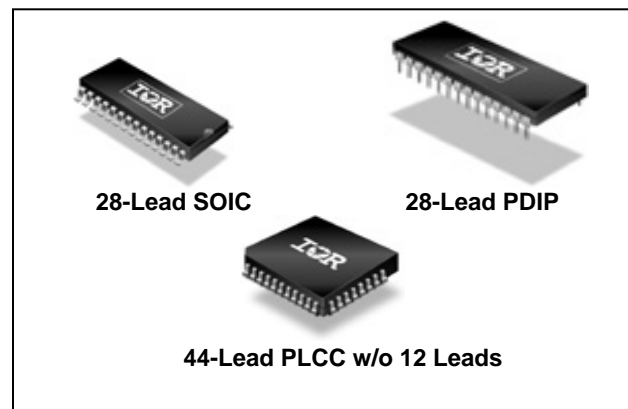

**Typical Connection**

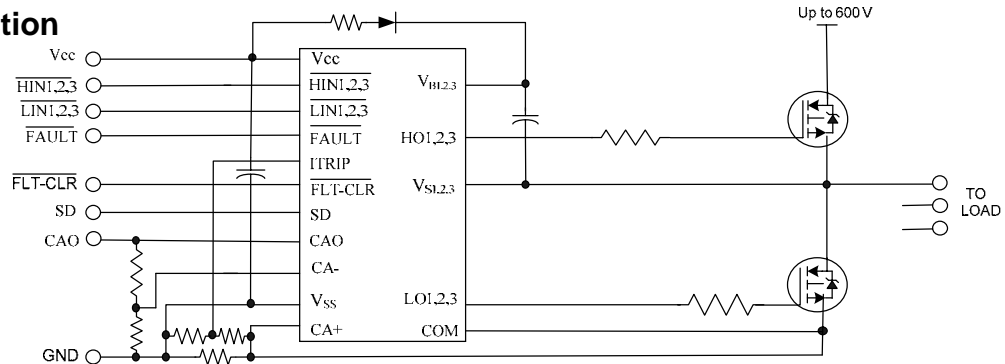

(Refer to Lead Assignments for correct pin configuration). This diagram shows electrical connections only. Please refer to our Application Notes and Design Tips for proper circuit board layout.

Absolute Maximum Ratings indicate sustained limits beyond which damage to the device may occur. All voltage parameters are absolute voltages referenced to COM. The thermal resistance and power dissipation ratings are measured under board mounted and still air conditions. Zener clamps are included between  $V_{CC}$  & COM (25 V),  $V_{CC}$  &  $V_{SS}$  (20V), and  $V_{Bx}$  &  $V_{Sx}$  (20 V).

Symbol	Definition	Min.	Max.	Units	
$V_{B1,2,3}$	High side floating supply voltage	-0.3	625	V	
$V_{S1,2,3}$	High side floating offset voltage	$V_{B1,2,3} - 20$	$V_{B1,2,3} + 0.3$		
$V_{HO1,2,3}$	High side floating output voltage	$V_{S1,2,3} - 0.3$	$V_{B1,2,3} + 0.3$		
$V_{CC}$	Fixed supply voltage	-0.3	25		
$V_{SS}$	Logic ground	$V_{CC} - 20$	$V_{CC} + 0.3$		
$V_{LO1,2,3}$	Low side output voltage	-0.3	$V_{CC} + 0.3$		
$V_{IN}$	Logic input voltage ( $\overline{HIN}$ , $\overline{LIN}$ ITRIP, SD & FLT-CLR)	$V_{SS} - 0.3$	$V_{CC} + 0.3$		
$V_{IN,AMP}$	Operational amplifier input voltage (CA+ & CA-)	$V_{SS} - 0.3$	$V_{CC} + 0.3$		
$V_{OUT,AMP}$	Operational amplifier output voltage (CAO)	$V_{SS} - 0.3$	$V_{CC} + 0.3$		
$V_{FLT}$	$\overline{FAULT}$ output voltage	$V_{SS} - 0.3$	$V_{CC} + 0.3$		
$dVs/dt$	Allowable offset supply voltage transient	—	50		V/ns
$P_D$	Package power dissipation @ $T_A \leq +25^\circ\text{C}$	(28 lead PDIP)	—	1.5	W
		(28 lead SOIC)	—	1.6	
		(44 lead PLCC)	—	2.0	
$R_{th,JA}$	Thermal resistance, junction to ambient	(28 lead PDIP)	—	83	$^\circ\text{C/W}$
		(28 lead SOIC)	—	78	
		(44 lead PLCC)	—	63	
$T_J$	Junction temperature	—	150	$^\circ\text{C}$	
$T_S$	Storage temperature	-55	150		
$T_L$	Lead temperature (soldering, 10 seconds)	—	300		

## Recommended Operating Conditions

The input/output logic timing diagram is shown in Fig. 1. For proper operation the device should be used within the recommended conditions. All voltage parameters are absolute voltage referenced to COM. The  $V_S$  offset rating is tested with all supplies biased at a 15 V differential.

Symbol	Definition	Min.	Max.	Units
$V_{B1,2,3}$	High side floating supply voltage	$V_{S1,2,3} + 10/12$	$V_{S1,2,3} + 20$	V
$V_{S1,2,3}$	High side floating offset voltage	Note 1	600	
$V_{HO1,2,3}$	High side floating output voltage	$V_{S1,2,3}$	$V_{B1,2,3}$	
$V_{CC}$	Fixed supply voltage	10 or 12	20	
$V_{SS}$	Low side driver return	-5	5	
$V_{LO1,2,3}$	Low side output voltage	0	$V_{CC}$	
$V_{IN}$	Logic input voltage ( $\overline{HIN}$ , $\overline{LIN}$ ITRIP, SD & FLT-CLR)	$V_{SS}$	$V_{SS} + 5$	
$V_{IN,AMP}$	Operational amplifier input voltage (CA+ & CA-)	$V_{SS}$	$V_{SS} + 5$	
$V_{OUT,AMP}$	Operational amplifier output voltage (CAO)	$V_{SS}$	$V_{SS} + 5$	
$V_{FLT}$	$\overline{FAULT}$ output voltage	$V_{SS}$	$V_{CC}$	

**Note 1:** Logic operational for  $V_S$  of (COM - 8 V) to (COM + 600 V). Logic state held for  $V_S$  of (COM - 8 V) to (COM -  $V_{BS}$ ). (Please refer to the Design Tip DT97-3 for more details).

**Note 2:** The CAO pin and all input pins (except CA+ & CA-) are internally clamped with a 5.2 V zener diode.

### Static Electrical Characteristics

$V_{BIAS}$  ( $V_{CC}$ ,  $V_{BS1,2,3}$ ) = 15 V, unless otherwise specified and  $T_A = 25\text{ }^\circ\text{C}$ . All static parameters other than  $I_O$  and  $V_O$  are referenced to  $V_{SS}$  and are applicable to all six channels (HIN1,2,3 & LIN1,2,3). The  $V_O$  and  $I_O$  parameters are referenced to COM and  $V_{S1,2,3}$  and are applicable to the respective output leads: HO1,2,3 or LO1,2,3.

Symbol	Definition	Min.	Typ.	Max.	Units	Test Conditions		
$V_{IH}$	Logic "0" input voltage (OUT = LO)	2.2	—	—	V			
$V_{IL}$	Logic "1" input voltage (OUT = HI)	—	—	0.8				
$V_{FCLR,IH}$	Logic "0" fault clear input voltage	2.2	—	—				
$V_{FCLR,IL}$	Logic "1" fault clear input voltage	—	—	0.8				
$V_{SD,TH+}$	SD input positive going threshold	1.6	1.9	2.2				
$V_{SD,TH-}$	SD input negative going threshold	1.4	1.7	2.0				
$V_{IT,TH+}$	ITRIP input positive going threshold	470	570	670	mV			
$V_{IT,TH-}$	ITRIP input negative going threshold	360	460	560				
$V_{OH}$	High level output voltage, $V_{BIAS} - V_O$	—	—	1	V	$V_{IN} = 0\text{ V}$ , $I_O = 20\text{ mA}$		
$V_{OL}$	Low level output voltage, $V_O$	—	—	400	mV	$V_{IN} = 5\text{ V}$ , $I_O = 20\text{ mA}$		
$I_{LK}$	Offset supply leakage current IRS213(3,5)	—	—	50	$\mu\text{A}$	$V_{B1,2,3} = V_{S1,2,3} = 600\text{ V}$		
$I_{QBS}$	Quiescent $V_{BS}$ supply current	—	45	70		$V_{IN} = 0\text{ V}$ or $5\text{ V}$		
$I_{QCC}$	Quiescent $V_{CC}$ supply current	—	3	5	mA	$V_{IN} = 0\text{ V}$ or $5\text{ V}$		
$I_{IN+}$	Logic "1" input bias current (OUT = HI)	—	150	200	$\mu\text{A}$	$V_{IN} = 0\text{ V}$		
$I_{IN-}$	Logic "0" input bias current (OUT = LO)	—	110	150		$V_{IN} = 5\text{ V}$		
$I_{SD+}$	"High" shutdown bias current	—	5	10		SD = 5 V		
$I_{SD-}$	"Low" shutdown bias current	—	—	100		SD = 0 V		
$I_{ITRIP+}$	"High" ITRIP bias current	—	5	10	$\mu\text{A}$	ITRIP = 5 V		
$I_{ITRIP-}$	"Low" ITRIP bias current	—	—	100	nA	ITRIP = 0 V		
$I_{FLTCLR+}$	"High" fault clear input bias current	—	150	200	$\mu\text{A}$	FLT-CLR = 0 V		
$I_{FLTCLR-}$	"Low" fault clear input bias current	—	110	150		FLT-CLR = 5 V		
$V_{BSUV+}$	$V_{BS}$ supply undervoltage positive going threshold	IRS2133	7.6	8.6	9.6	V		
		IRS2135	9.2	10.4	11.6			
$V_{BSUV-}$	$V_{BS}$ supply undervoltage negative going threshold	IRS2133	7.2	8.2	9.2			
		IRS2135	8.3	9.4	10.5			
$V_{BSUVH}$	$V_{BS}$ supply undervoltage lockout hysteresis	IRS2133	—	0.4	—			
		IRS2135	—	1	—			
$V_{CCUV+}$	$V_{CC}$ supply undervoltage positive going threshold	IRS2133	7.6	8.6	9.6			
		IRS2135	9.2	10.4	11.6			
$V_{CCUV-}$	$V_{CC}$ supply undervoltage negative going threshold	IRS2133	7.2	8.2	9.2			
		IRS2135	8.3	9.4	10.5			
$V_{CCUVH}$	$V_{CC}$ supply undervoltage lockout hysteresis	IRS2133	—	0.4	—			
		IRS2135	—	1	—			
$R_{on,FLT}$	$\overline{\text{FAULT}}$ low on-resistance	—	55	75	$\Omega$			
$I_{O+}$	Output high short circuit pulsed current	200	250	—	mA			$V_{OUT} = 0\text{ V}$ , $V_{IN} = 0\text{ V}$ PW $\leq 10\text{ }\mu\text{s}$
$I_{O-}$	Output low short circuit pulsed current	420	500	—		$V_{OUT} = 15\text{ V}$ , $V_{IN} = 5\text{ V}$ PW $\leq 10\text{ }\mu\text{s}$		

### Static Electrical Characteristics – (Continued)

$V_{BIAS}$  ( $V_{CC}$ ,  $V_{BS1,2,3}$ ) = 15 V, unless otherwise specified and  $T_A = 25^\circ\text{C}$ . All static parameters other than  $I_O$  and  $V_O$  are referenced to  $V_{SS}$  and are applicable to all six channels (HIN1,2,3 & LIN1,2,3). The  $V_O$  and  $I_O$  parameters are referenced to COM and  $V_{S1,2,3}$  and are applicable to the respective output leads: HO1,2,3 or LO1,2,3.

Symbol	Definition	Min.	Typ.	Max.	Units	Test Conditions
$V_{OS}$	Amplifier input offset voltage	—	—	10	mV	CA+ = 0.2 V, CA- = CAO
$I_{IN,AMP}$	Amplifier input bias current	—	—	50	nA	CA+ = CA- = 2.5 V
CMRR	Amplifier common mode rejection ratio	TBD	80	—	dB	CA+ = 0.1 V & 5 V, CA- = CAO
PSRR	Amplifier power supply rejection ratio	TBD	75	—		CA+ = 0.2 V, CA- = CAO, $V_{CC} = 10\text{ V} \& 20\text{ V}$
$V_{OH,AMP}$	Operational amplifier high level output voltage	4.9	5.2	5.4	V	CA+ = 1 V, CA- = 0 V
$V_{OL,AMP}$	Operational amplifier low level output voltage	—	—	30	mV	CA+ = 0 V, CA- = 1 V
$I_{SRC,AMP}$	Operational amplifier output source current	4	7	—	mA	CA+ = 1 V, CA- = 0 V, CAO = 4 V
$I_{SNK,AMP}$	Operational amplifier output sink current	1	2.1	—		CA+ = 0 V, CA- = 1 V, CAO = 2 V
$I_{O+,AMP}$	Operational amplifier output high short circuit current	—	10	—		CA+ = 5 V, CA- = 0 V, CAO = 0 V
$I_{O-,AMP}$	Operational amplifier output low short circuit current	—	4	—		CA+ = 0 V, CA- = 5 V, CAO = 5 V

### Dynamic Electrical Characteristics

$V_{BIAS}$  ( $V_{CC}$ ,  $V_{BS1,2,3}$ ) = 15 V,  $V_{S1,2,3} = V_{SS}$ ,  $T_A = 25^\circ\text{C}$  and  $C_L = 1000\text{ pF}$  unless otherwise specified.

Symbol	Definition	Min.	Typ.	Max.	Units	Test Conditions
$t_{on}$	Turn-on propagation delay	400	500	700	ns	$V_{IN} = 0\text{ V} \& 5\text{ V}$ $V_{S1,2,3} = 0\text{ V} \text{ to } 600\text{ V}$
$t_{off}$	Turn-off propagation delay	400	500	700		
$t_r$	Turn-on rise time	—	80	125		
$t_f$	Turn-off fall time	—	35	55		
$t_{sd}$	SD to output shutdown propagation delay	400	550	750		
$t_{itrip}$	ITRIP to output shutdown propagation delay	400	660	920		
$t_{bl}$	ITRIP blanking time	—	400	—		
$t_{fit}$	ITRIP to $\overline{\text{FAULT}}$ propagation delay	350	550	870		
$t_{fit, in}$	Input filter time ( $\overline{\text{HIN}}$ , $\overline{\text{LIN}}$ , and SD)	—	325	—		
$t_{fitclr}$	FLT-CLR to $\overline{\text{FAULT}}$ clear time	600	850	1100		
DT	Deadtime (LS turn-off to HS turn-on & HS turn-off to LS turn-on)	150	230	350	V/ $\mu\text{s}$	1 V step input
SR+	Operational amplifier slew rate (+)	5	10	—		
SR-	Operational amplifier slew rate (-)	2.4	3.2	—		

**NOTE:** For high side PWM, HIN pulse width must be  $\geq 1\ \mu\text{s}$ .

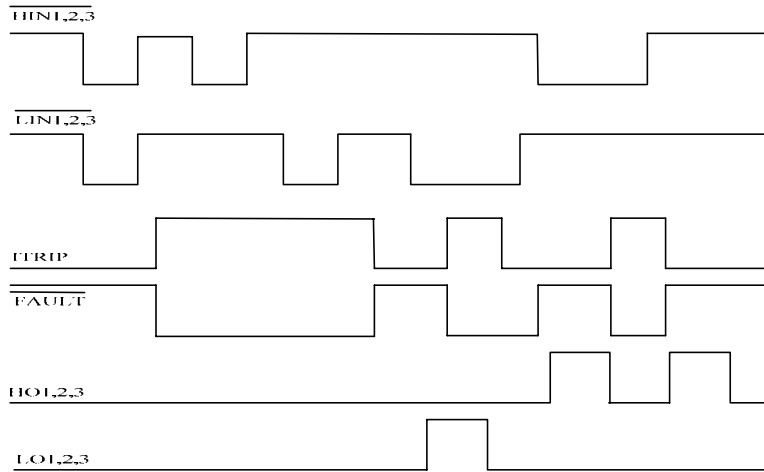

Fig. 1. Input/Output Timing Diagram

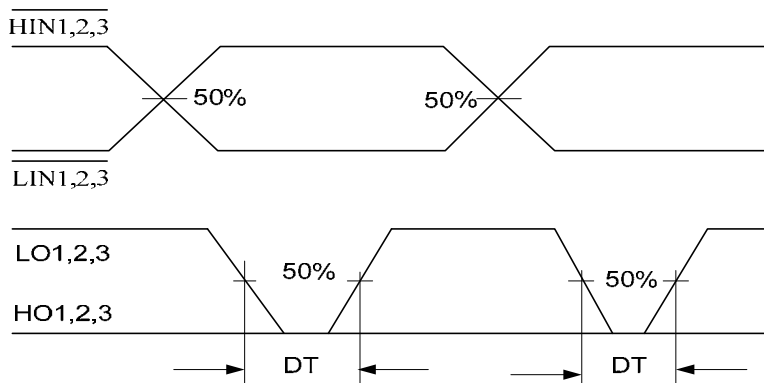

Fig. 2. Deadtime Waveform Definitions

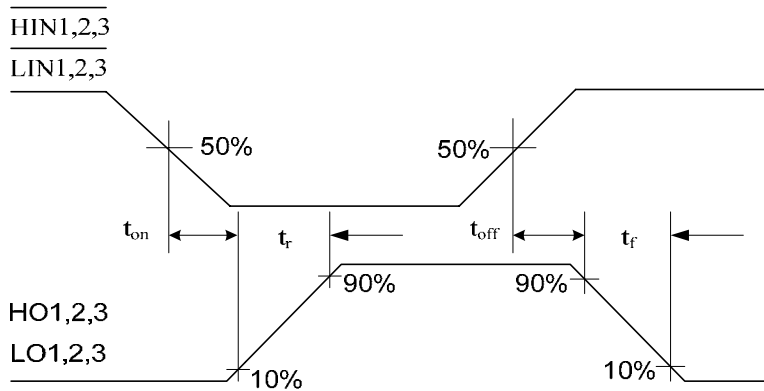

Fig. 3. Input/Output Switching Time Waveform Definitions

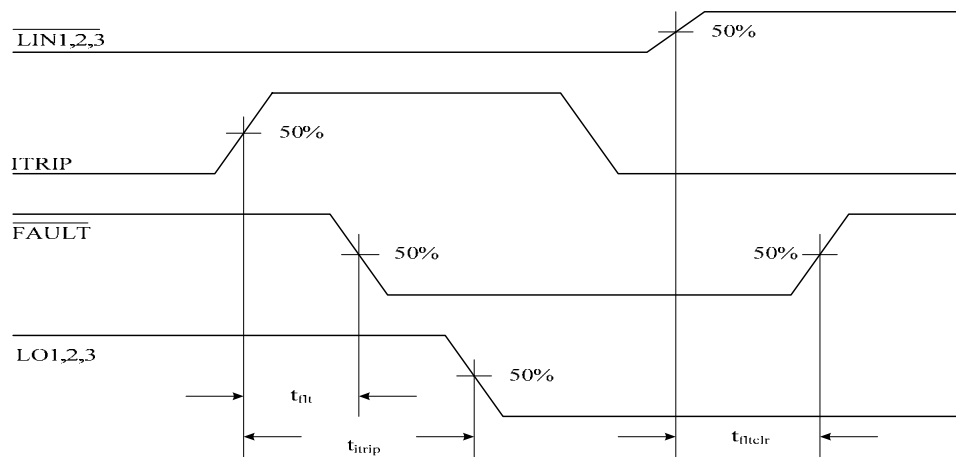

Fig. 4. Overcurrent Shutdown Switching Time Waveform Definitions

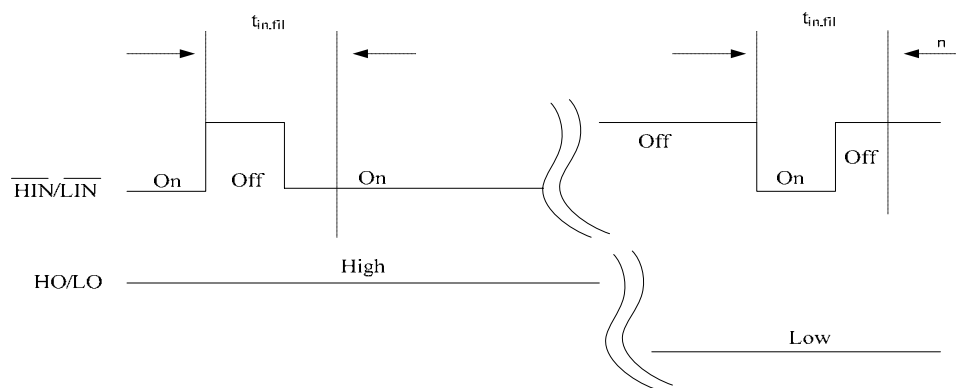

Fig. 5. Input Filter Function

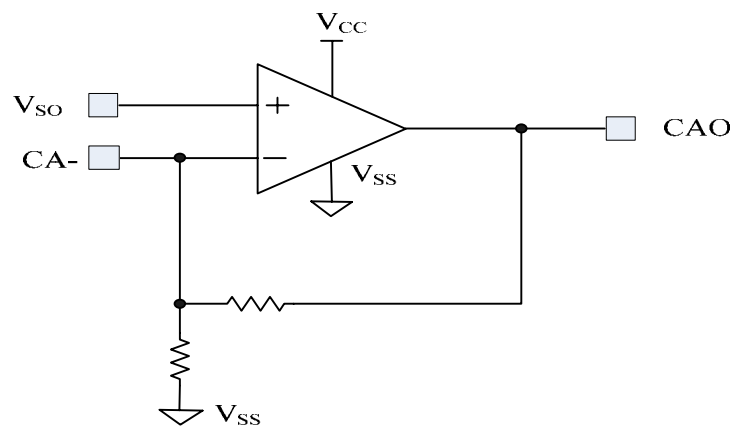
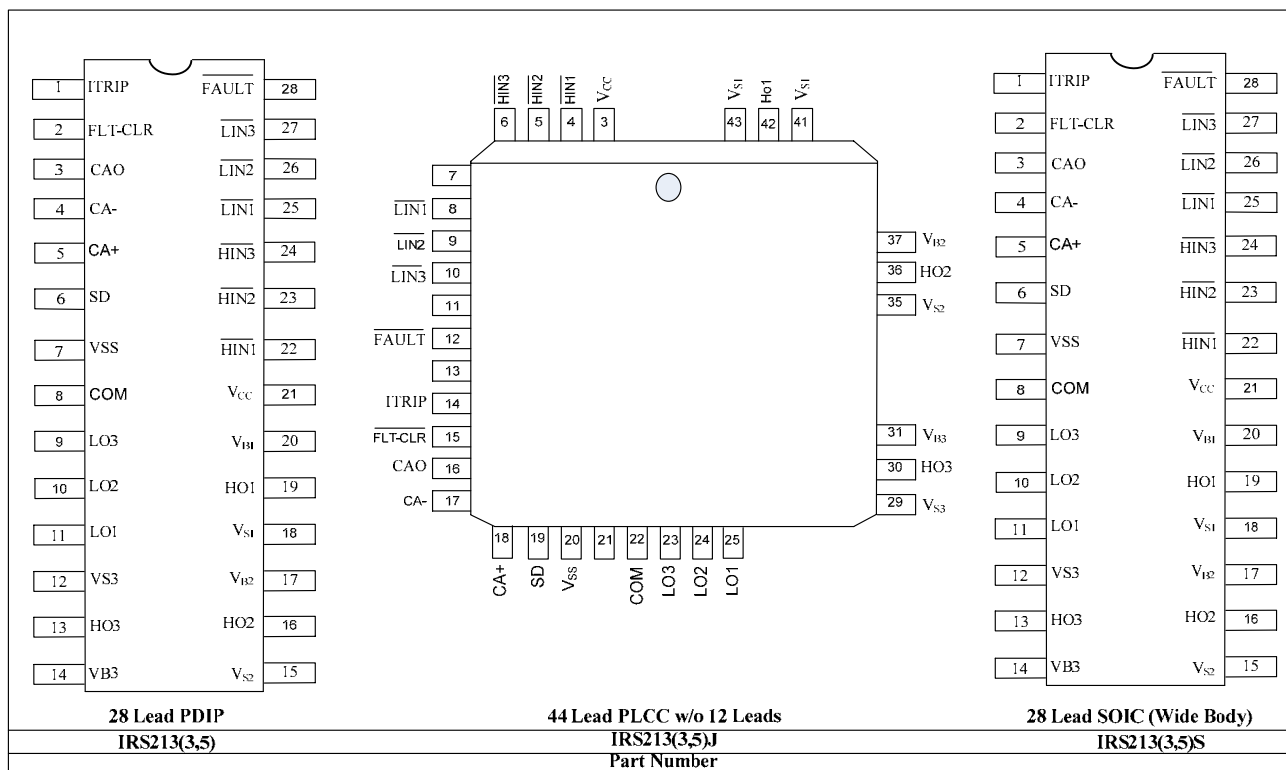

Fig. 6. Diagnostic Feedback Operational Amplifier Circuit

### Lead Definitions

Symbol	Description
HIN1,2,3	Logic input for high side gate driver outputs (HO1,2,3), out of phase
LIN1,2,3	Logic input for low side gate driver outputs (LO1,2,3), out of phase
$\overline{\text{FAULT}}$	Indicates over-current or undervoltage lockout (low side) has occurred, negative logic
V <sub>CC</sub>	Logic and low side fixed supply
ITRIP	Input for over-current shut down
$\overline{\text{FLT-CLR}}$	Logic input for fault clear, negative logic
SD	Logic input for shutdown
CAO	Output of current amplifier
CA-	Negative input of current amplifier
CA+	Positive input of current amplifier
V <sub>SS</sub>	Logic ground
Com	Low side return
V <sub>B1,2,3</sub>	High side floating supplies
HO1,2,3	High side gate drive outputs
V <sub>S1,2,3</sub>	High side floating supply returns
LO1,2,3	Low side gate drive outputs

### Lead Assignments



Functional Block Diagram

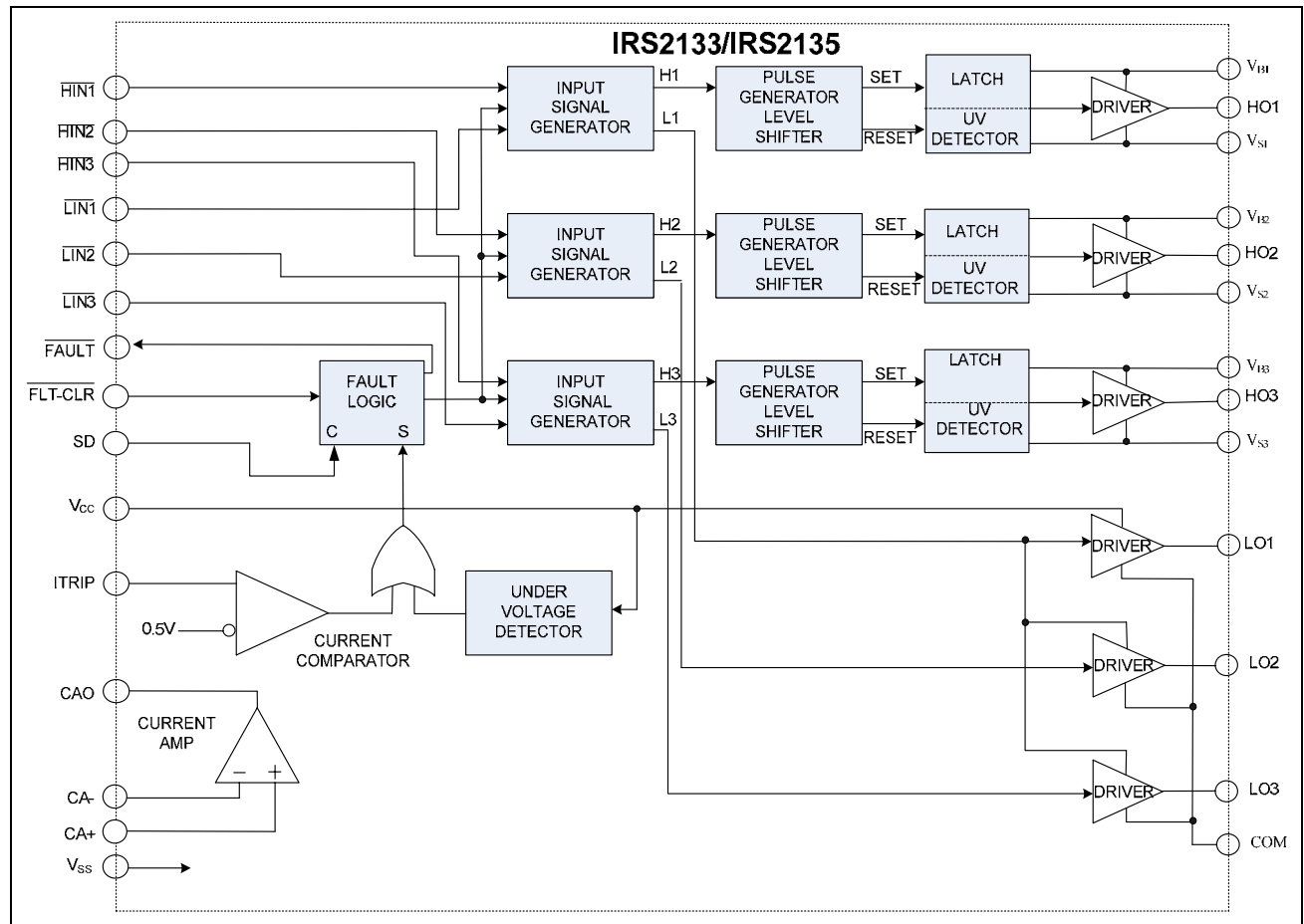



## 1 PCB Layout Tips

### 1.1 Distance from H to L Voltage

The IRS213(3,5)J package lacks some pins (see page 7) in order to maximizing the distance between the high voltage and low voltage pins. It's strongly recommended to place the components tied to the floating voltage in the respective high voltage portions of the device ( $V_{B1,2,3}$ ,  $V_{S1,2,3}$ ) side.

### 1.2 Ground Plane

To minimize noise coupling ground plane must not be placed under or near the high voltage floating side.

### 1.3 Gate Drive Loops

Current loops behave like an antenna able to receive and transmit EM noise (see Fig. 7). In order to reduce EM coupling and improve the power switch turn on/off performances, gate drive loops must be reduced as much as possible. Moreover, current can be injected inside the gate drive loop via the IGBT collector-to-gate parasitic capacitance. The parasitic auto-inductance of the gate loop contributes to develop a voltage across the gate-emitter increasing the possibility of self turn-on effect.

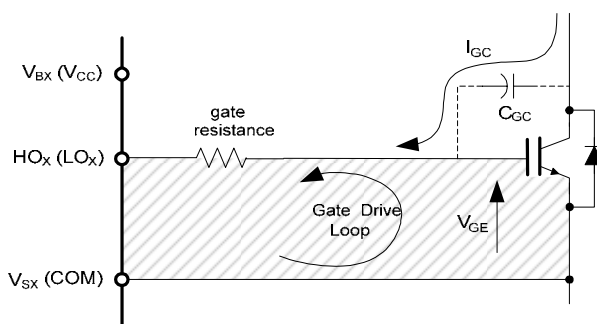

Fig. 7. Antenna Loops

### 1.4 Supply Capacitors

Supply capacitors must be placed as close as possible to the device pins ( $V_{CC}$  and  $V_{SS}$  for the ground tied supply,  $V_B$  and  $V_S$  for the floating supply) in order to minimize parasitic inductance/resistance.

### 1.5 Routing and Placement

Power stage PCB parasitic may generate dangerous voltage transients for the gate driver and the control logic. In particular it's recommended to limit phase voltage negative transients.

In order to avoid such undervoltage it is highly recommended to minimize high side emitter to low side collector distance and low side emitter to negative bus rail stray inductance. See DT04-4 at [www.irf.com](http://www.irf.com) for more detailed information.

Figures 8-38 provide information on the experimental performance of the IRS2133S HVIC. The line plotted in each figure is generated from actual lab data. A large number of individual samples were tested at three temperatures (-40 °C, 25 °C, and 125 °C) in order to generate the experimental (Exp.) curve. The line labeled Exp. consist of three data points (one data point at each of the tested temperatures) that have been connected together to illustrate the understood trend. The individual data points on the curve were determined by calculating the averaged experimental value of the parameter (for a given temperature).

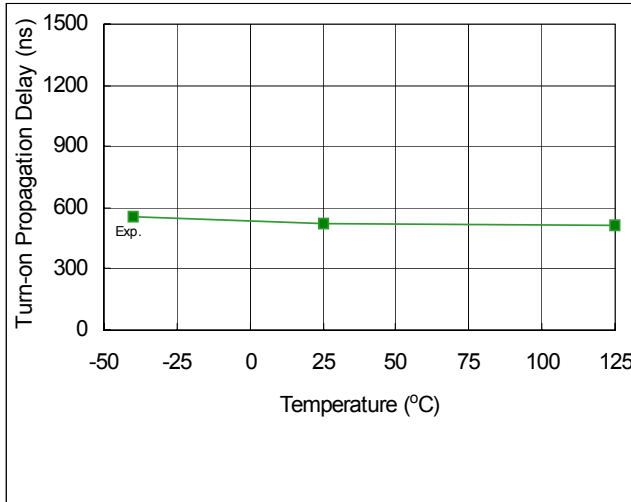

Fig. 8. Turn-On Propagation Delay vs. Temperature

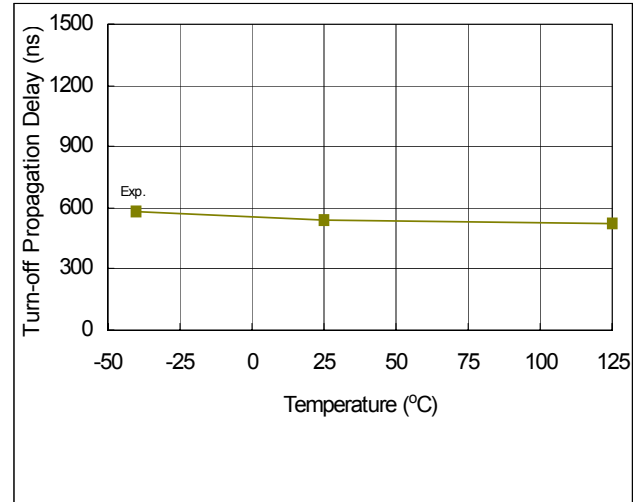

Fig. 9. Turn-Off Propagation Delay vs. Temperature

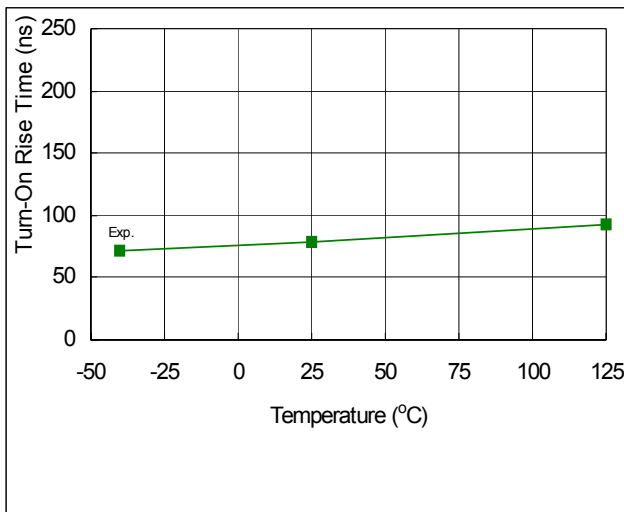

Fig. 10. Turn-On Rise Time vs. Temperature

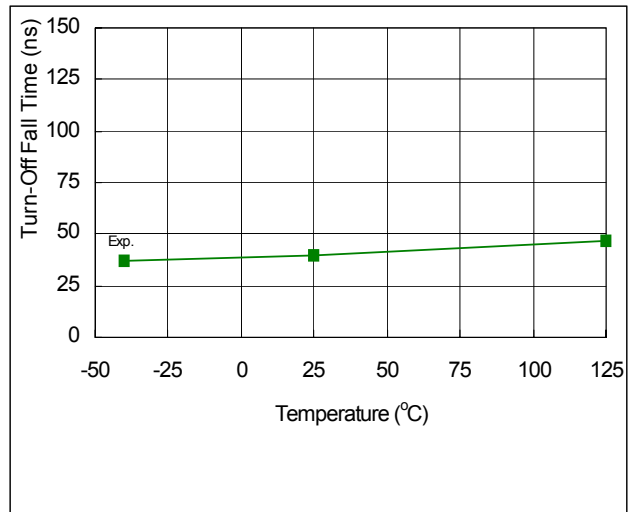

Fig. 11. Turn-Off Fall Time vs. Temperature

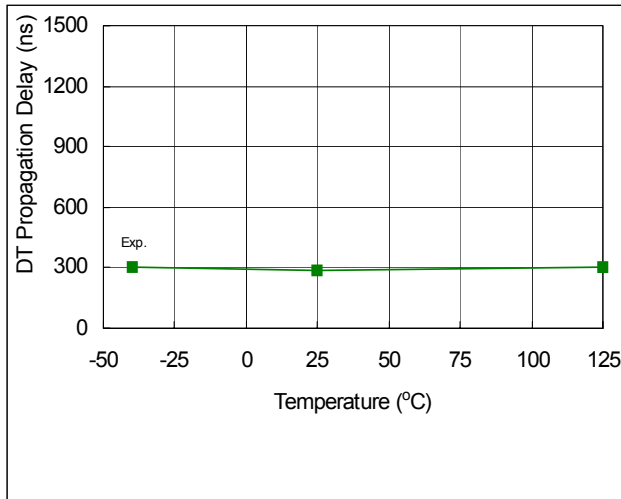

Fig. 12. DT Propagation Delay vs. Temperature

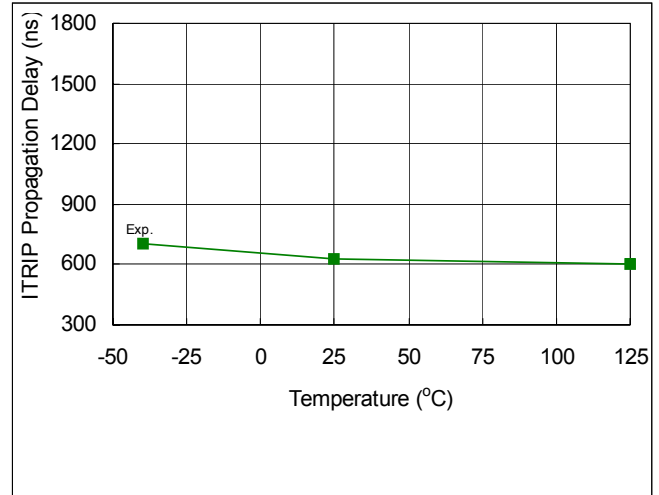

Fig. 13.  $T_{ITRIP}$  Propagation Delay vs. Temperature

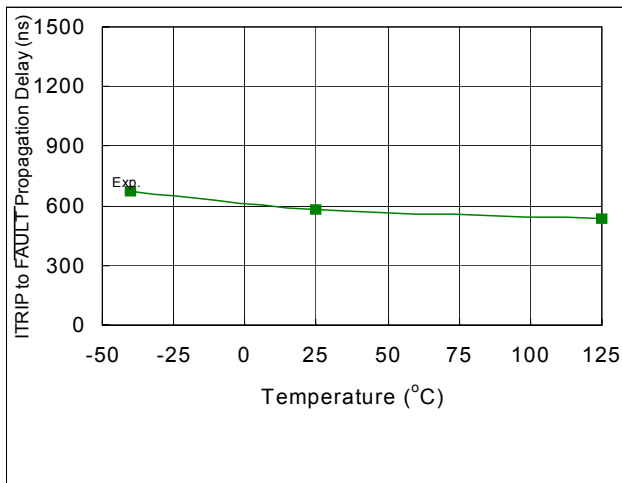

Fig. 14. ITRIP to FAULT Propagation Delay vs. Temperature

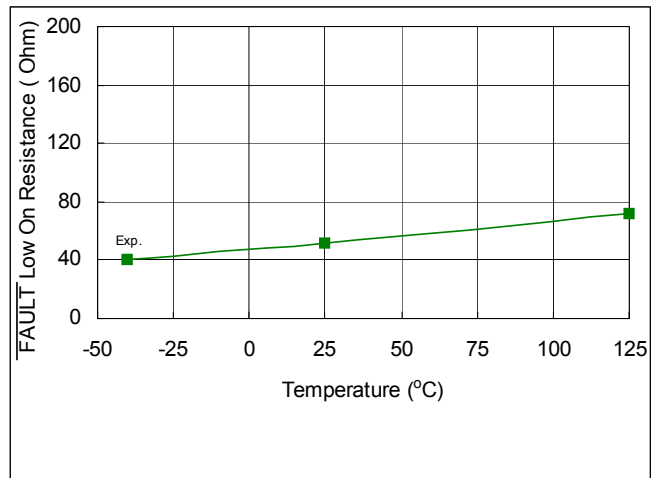

Fig. 15. FAULT Low On Resistance vs. Temperature

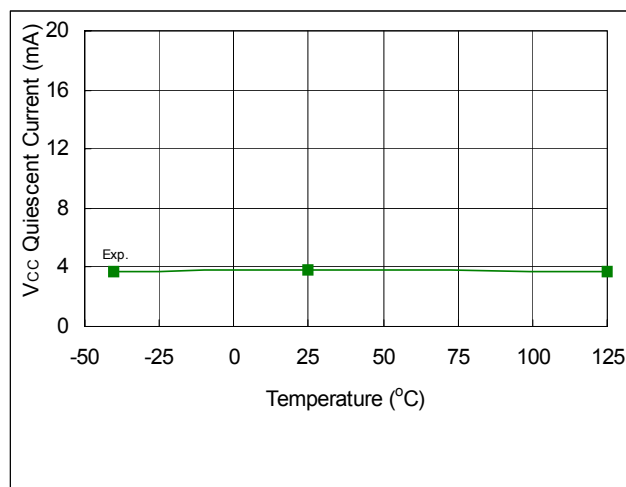

Fig. 16.  $V_{CC}$  Quiescent Current vs. Temperature

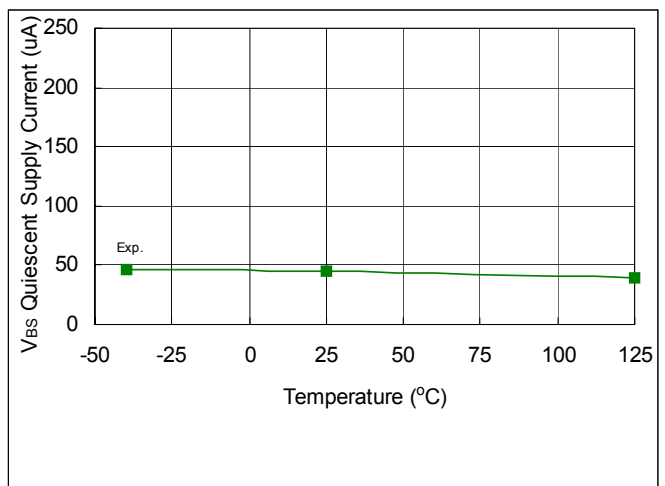

Fig. 17.  $V_{BS}$  Quiescent Current vs. Temperature

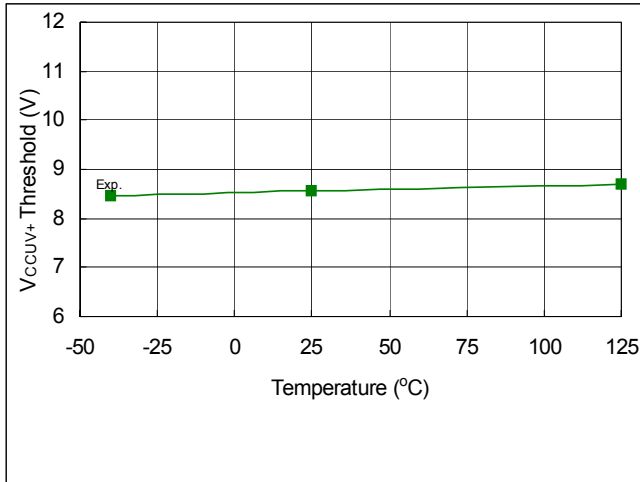

Fig. 18. V<sub>CCUV+</sub> Threshold vs. Temperature

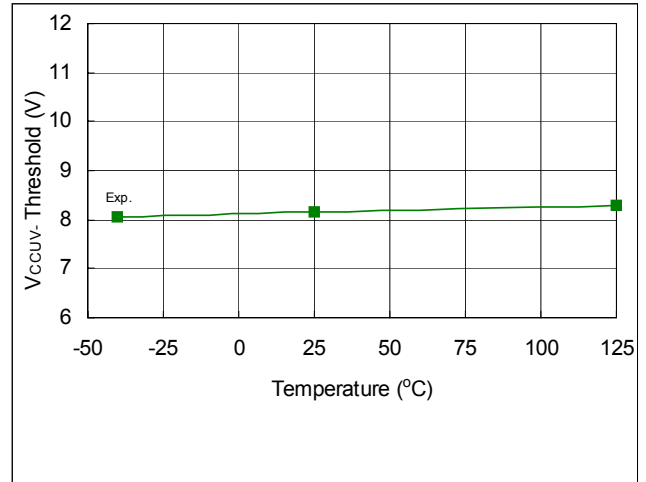

Fig. 19. V<sub>CCUV-</sub> Threshold vs. Temperature

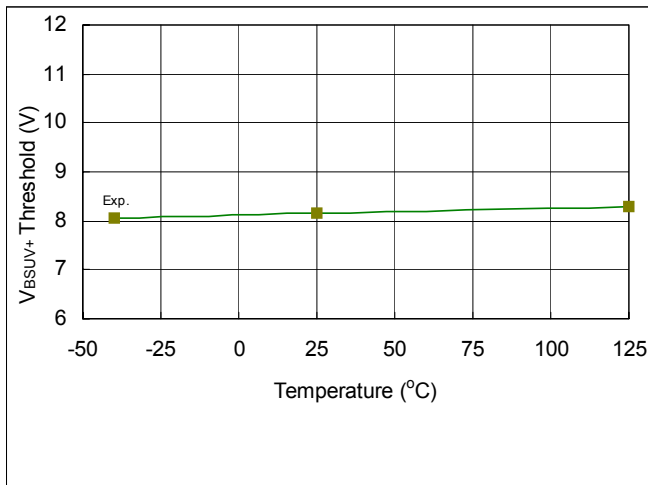

Fig. 20. V<sub>BSUV+</sub> Threshold vs. Temperature

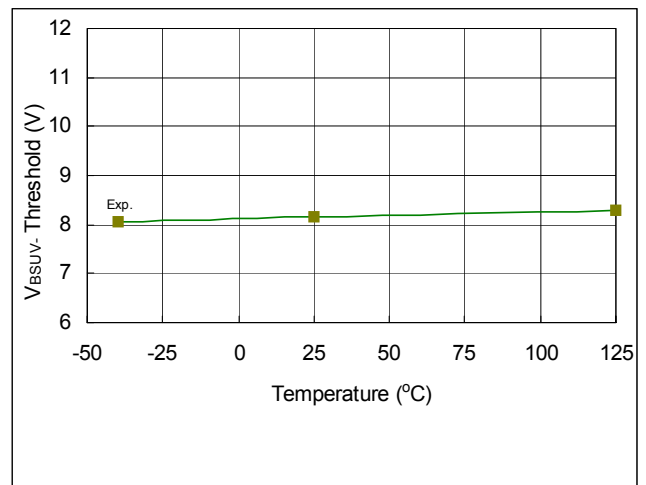

Fig. 21. V<sub>BSUV-</sub> Threshold vs. Temperature

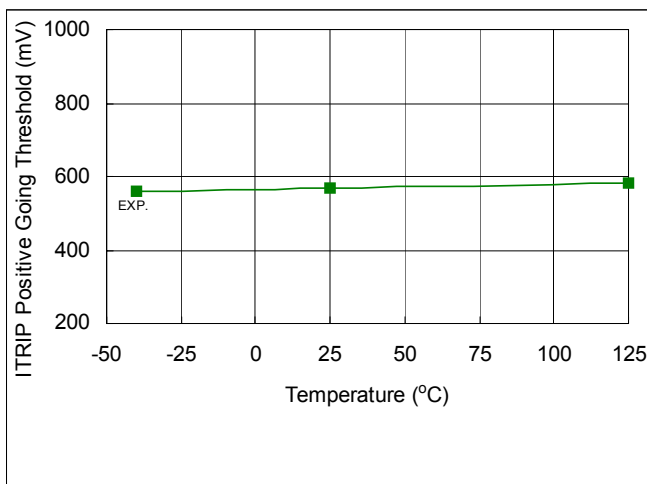

Fig. 22. ITRIP Positive Going Threshold vs. Temperature

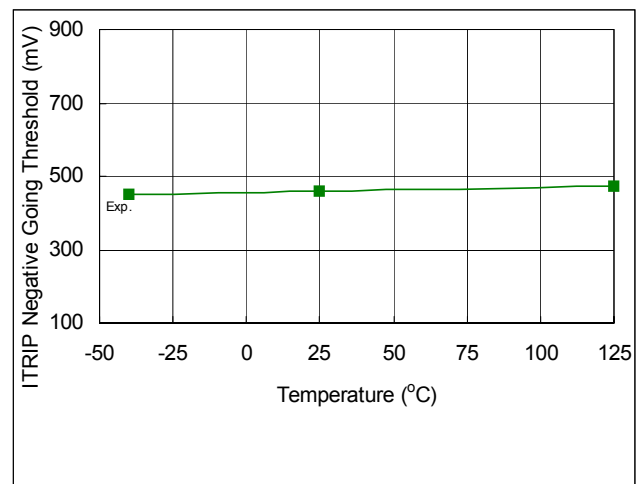

Fig. 23. ITRIP Negative Going Threshold vs. Temperature

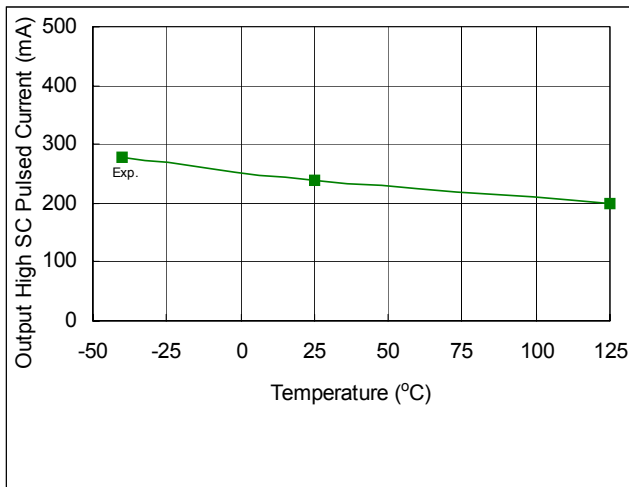

Fig. 24. Output High SC Pulsed Current vs. Temperature

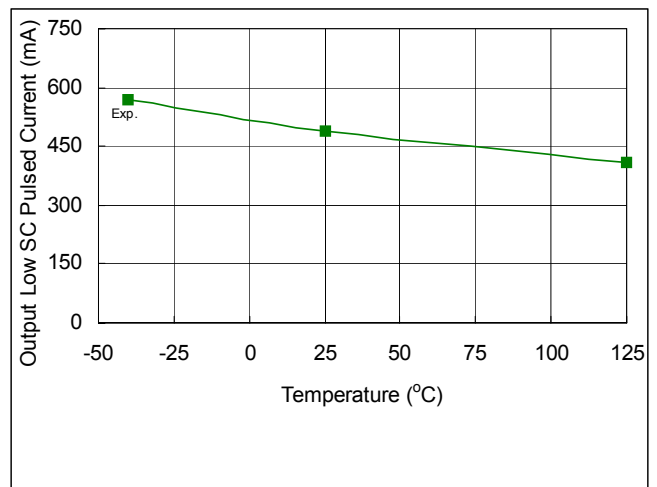

Fig. 25. Output Low SC Pulsed Current vs. Temperature

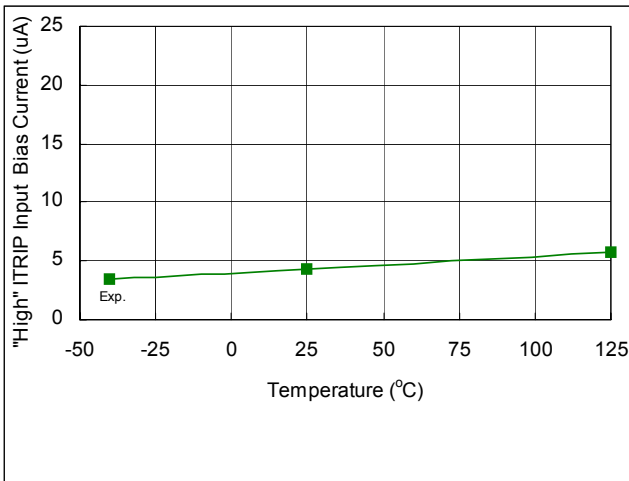

Fig. 26. "High" ITRIP Bias Current vs. Temperature

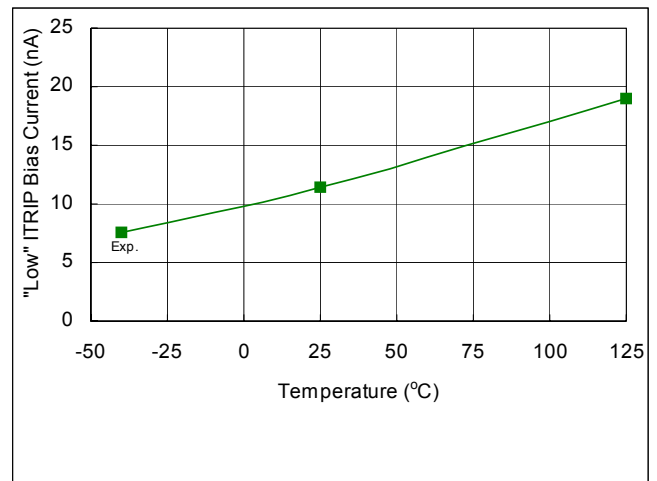

Fig. 27. "Low" ITRIP Bias Current vs. Temperature

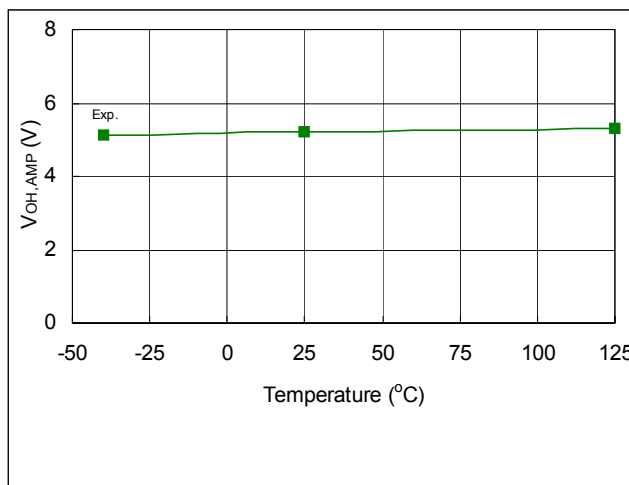

Fig. 28. V<sub>OH,AMP</sub> vs. Temperature

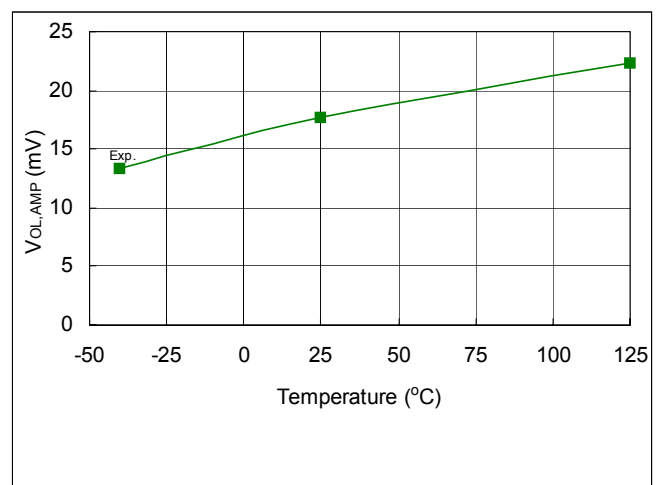

Fig. 29. V<sub>OL,AMP</sub> vs. Temperature

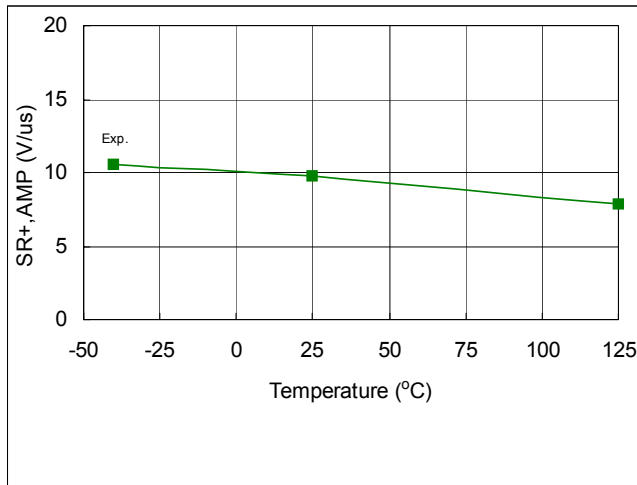

Fig. 30. SR+,AMP vs. Temperature

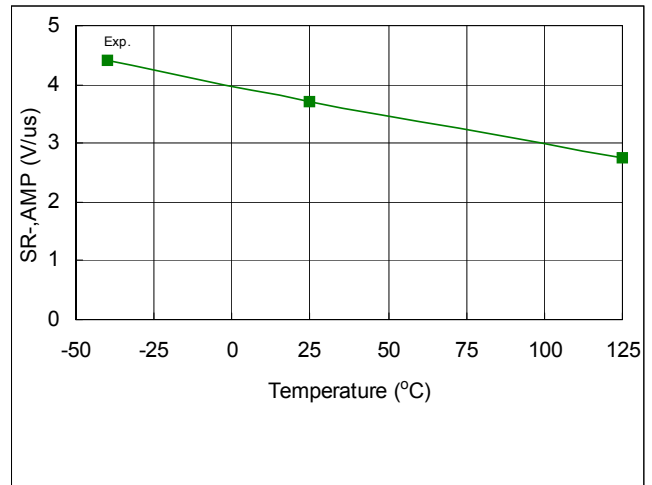

Fig. 31. SR-,AMP vs. Temperature

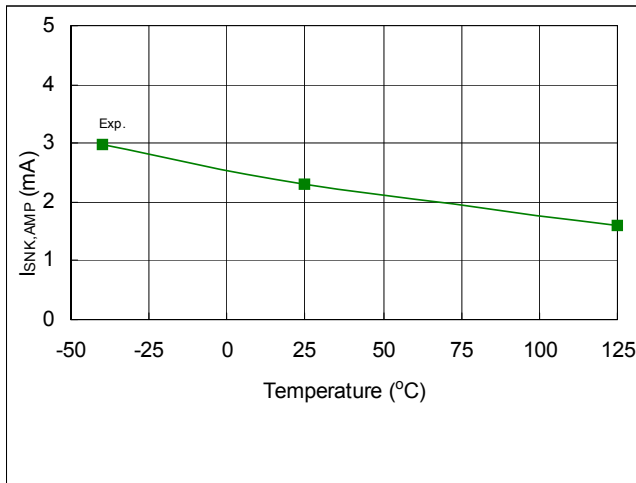

Fig. 32. ISNK,AMP vs. Temperature

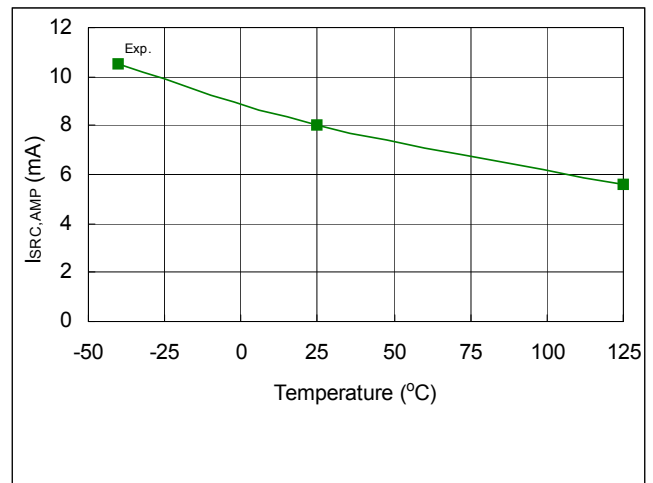

Fig. 33. ISRC,AMP vs. Temperature

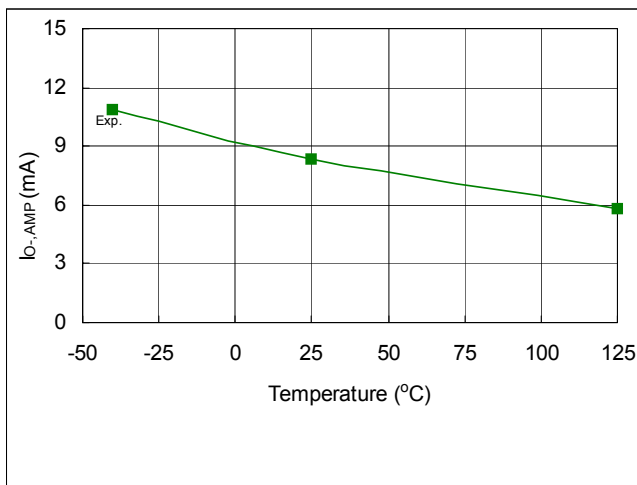

Fig. 34. IO-,AMP vs. Temperature

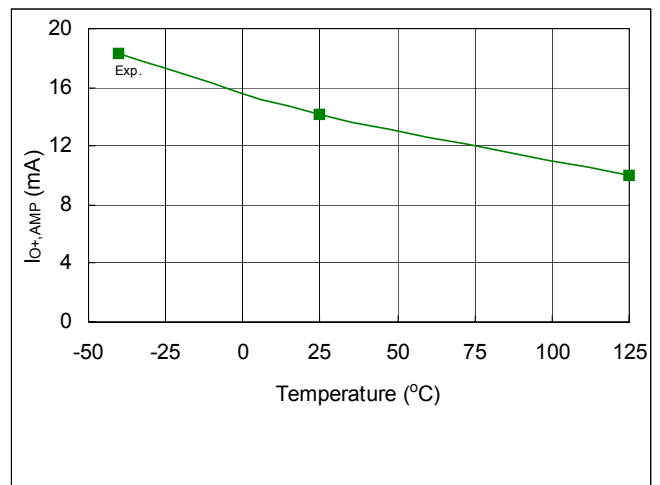

Fig. 35. IO+,AMP vs. Temperature

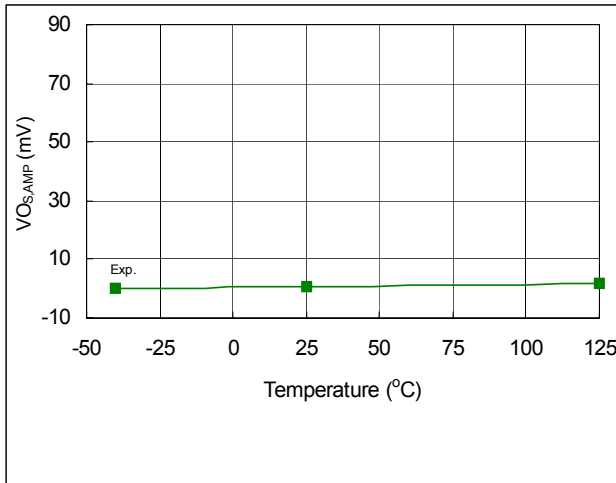

Fig. 36.  $V_{OS,AMP}$  vs. Temperature

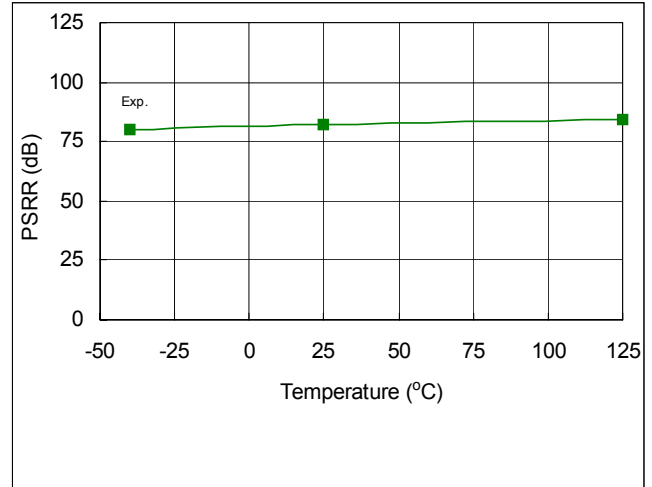

Fig. 37. PSRR vs. Temperature

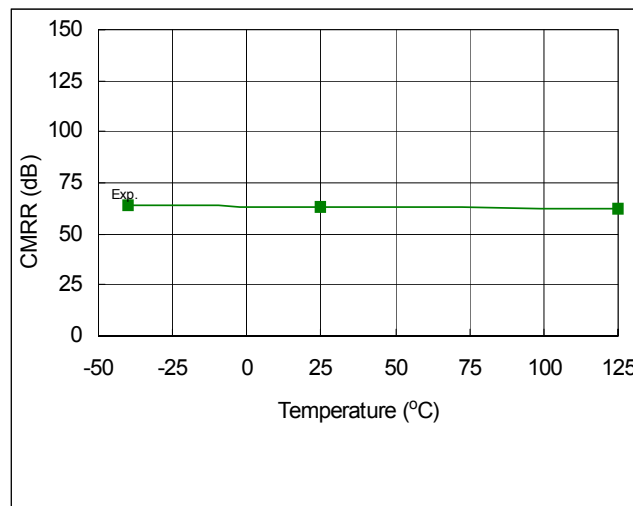
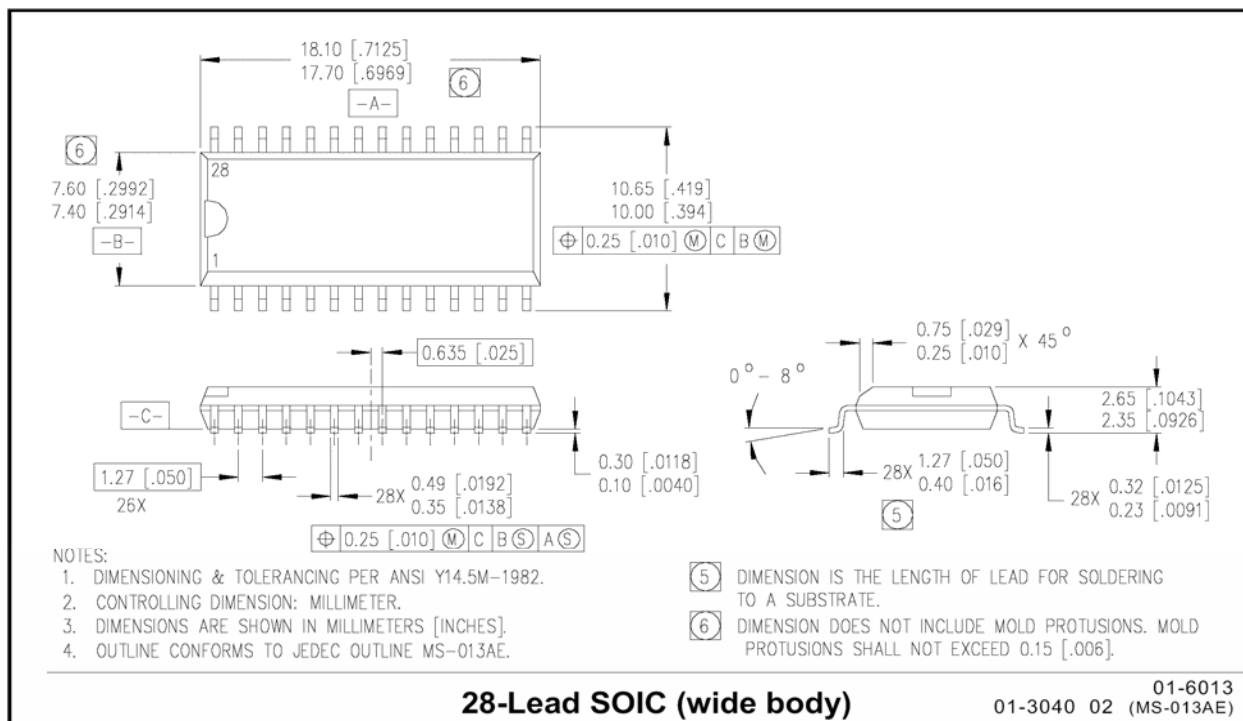
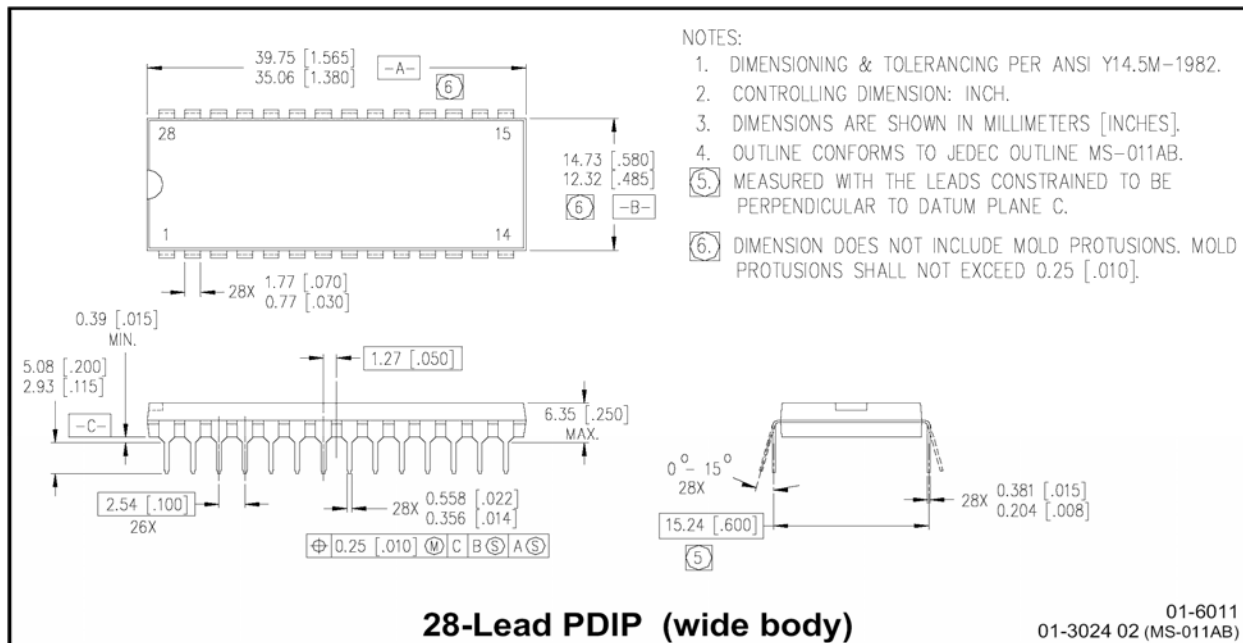

Fig. 38. CMRR vs. Temperature

### Case Outlines





Case Outlines

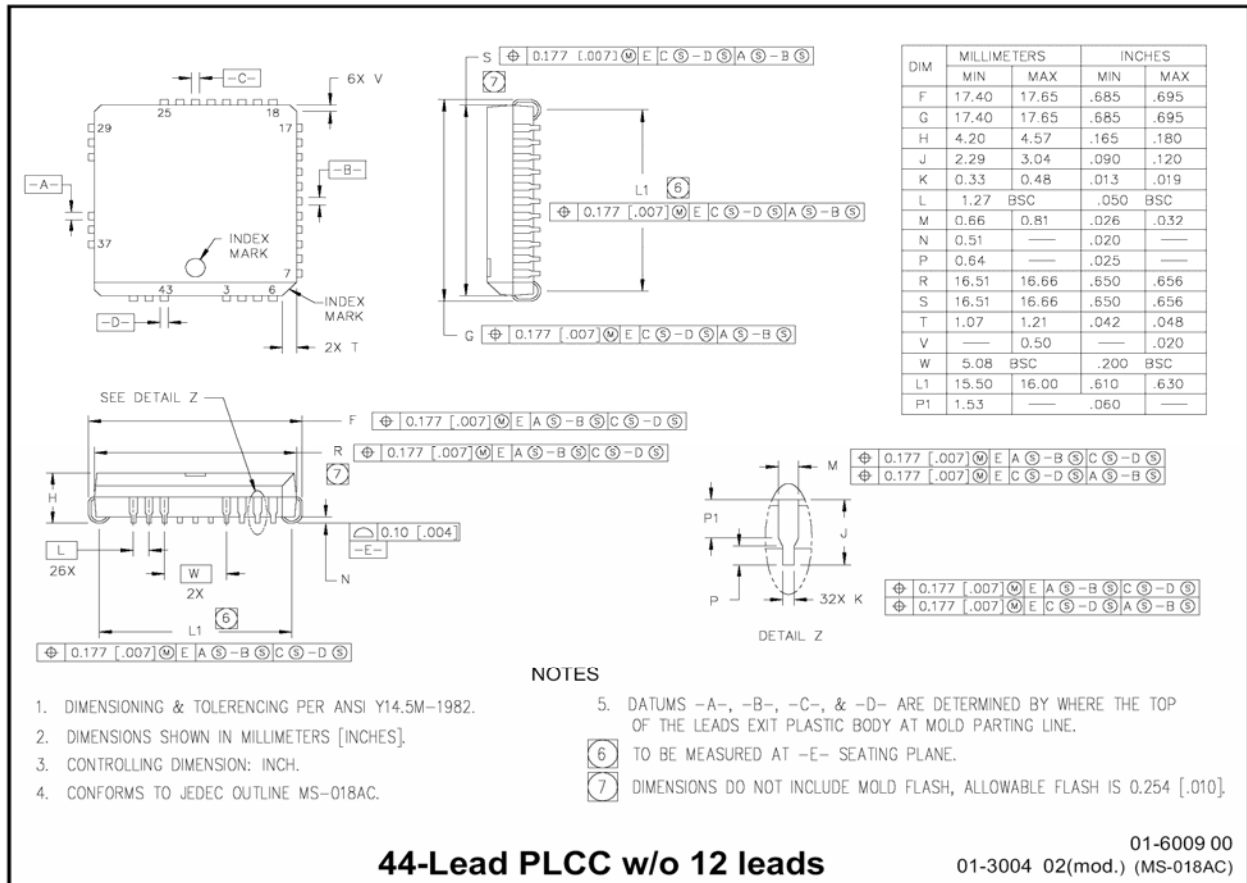

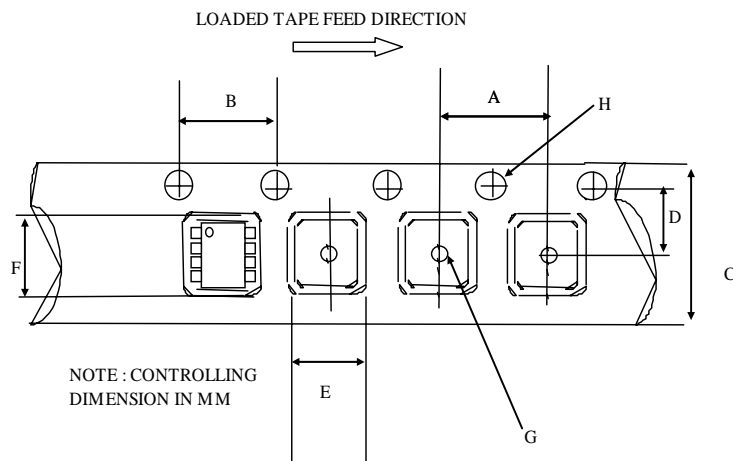

CARRIER TAPE DIMENSION FOR 28SOICW

Code	Metric		Imperial	
	Min	Max	Min	Max
A	11.90	12.10	0.468	0.476
B	3.90	4.10	0.153	0.161
C	23.70	24.30	0.933	0.956
D	11.40	11.60	0.448	0.456
E	10.80	11.00	0.425	0.433
F	18.20	18.40	0.716	0.724
G	1.50	n/a	0.059	n/a
H	1.50	1.60	0.059	0.062

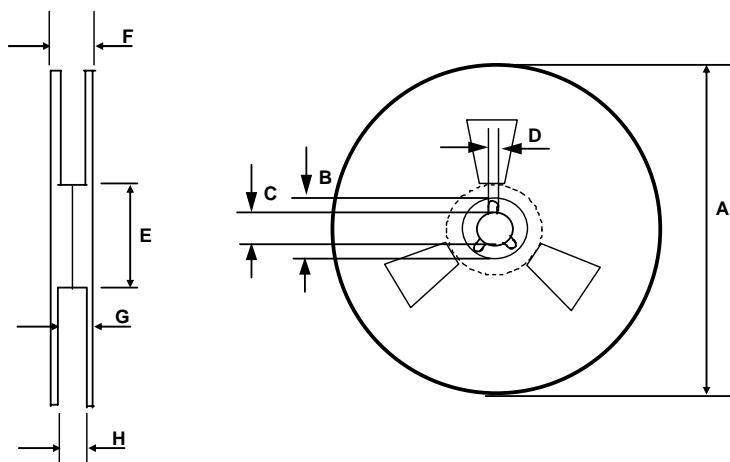

REEL DIMENSIONS FOR 28SOICW

Code	Metric		Imperial	
	Min	Max	Min	Max
A	329.60	330.25	12.976	13.001
B	20.95	21.45	0.824	0.844
C	12.80	13.20	0.503	0.519
D	1.95	2.45	0.767	0.096
E	98.00	102.00	3.858	4.015
F	n/a	30.40	n/a	1.196
G	26.50	29.10	1.04	1.145
H	24.40	26.40	0.96	1.039

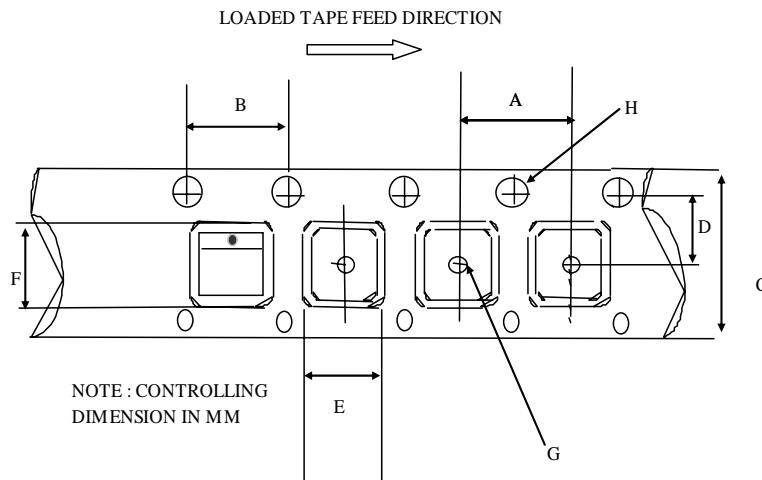

CARRIER TAPE DIMENSION FOR 44PLCC

Code	Metric		Imperial	
	Min	Max	Min	Max
A	23.90	24.10	0.94	0.948
B	3.90	4.10	0.153	0.161
C	31.70	32.30	1.248	1.271
D	14.10	14.30	0.555	0.562
E	17.90	18.10	0.704	0.712
F	17.90	18.10	0.704	0.712
G	2.00	n/a	0.078	n/a
H	1.50	1.60	0.059	0.062

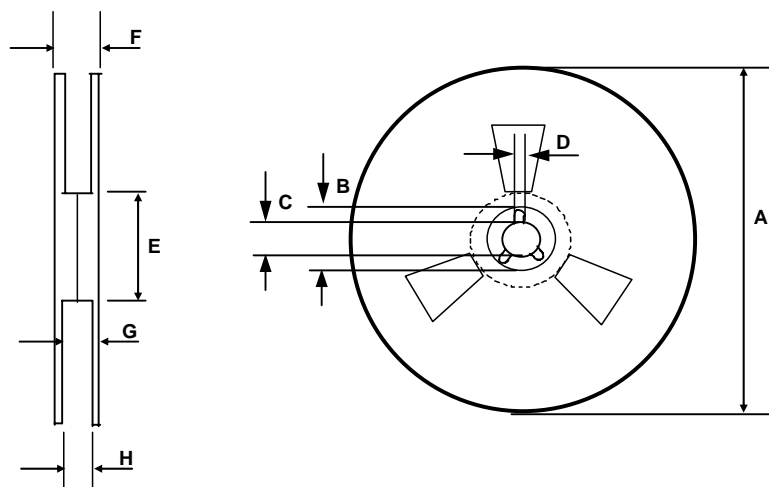

REEL DIMENSIONS FOR 44PLCC

Code	Metric		Imperial	
	Min	Max	Min	Max
A	329.60	330.25	12.976	13.001
B	20.95	21.45	0.824	0.844
C	12.80	13.20	0.503	0.519
D	1.95	2.45	0.767	0.096
E	98.00	102.00	3.858	4.015
F	n/a	38.4	n/a	1.511
G	34.7	35.8	1.366	1.409
H	32.6	33.1	1.283	1.303

**LEAD-FREE PART MARKING INFORMATION**

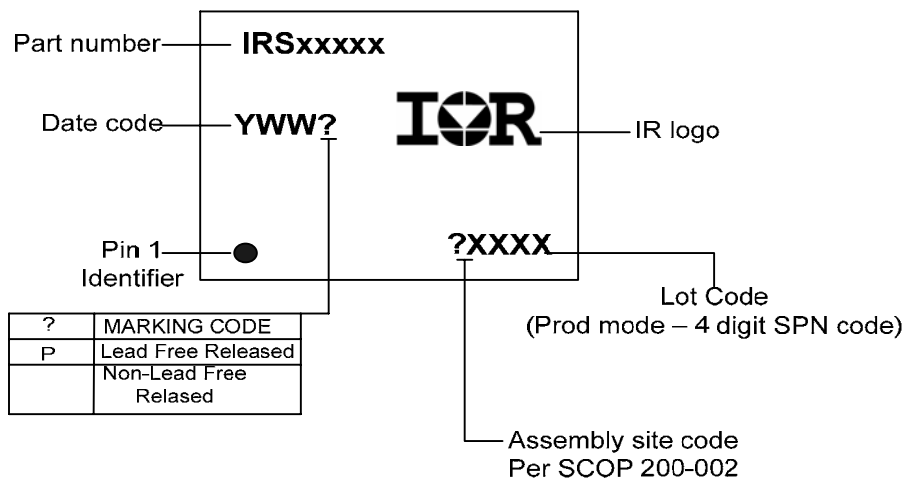

**ORDER INFORMATION**

- 28-Lead PDIP IRS2133PbF
- 28-Lead PDIP IRS2135PbF
- 28-Lead SOIC IRS2133SPbF
- 28-Lead SOIC IRS2135SPbF
- 44-Lead PLCC IRS2133JPbF
- 44-Lead PLCC IRS2135JPbF

- 28-Lead SOIC Tape & Reel IRS2133STRPbF
- 28-Lead SOIC Tape & Reel IRS2135STRPbF
- 44-Lead PLCC Tape & Reel IRS2133JTRPbF
- 44-Lead PLCC Tape & Reel IRS2135JTRPbF