

IRS2130/IRS21303/IRS2132 (J&S)PbF

3-PHASE BRIDGE DRIVER

Features

- Floating channel designed for bootstrap operation
- Fully operational to +600 V
- Tolerant to negative transient voltage, dV/dt immune
- Gate drive supply range from 10 V to 20 V
- Undervoltage lockout for all channels
- Over-current shutdown turns off all six drivers
- Three Independent half-bridge drivers
- Matched propagation delay for all channels
- 2.5 V logic compatible
- Outputs out of phase with inputs
- Cross-conduction prevention logic
- All parts are LEAD-FREE

Product Summary

V_{OFFSET}	600 V max.
$I_{\text{O}+/-}$ (min.)	200 mA / 420 mA
V_{OUT}	10 V – 20 V (IRS213(0,2)) 13 V – 20 V (IRS21303)
$t_{\text{on/off}}$ (typ.)	500 ns
Deadtime (typ.)	2.0 μs (IRS2130) 0.7 μs (IRS213(2,03))

Applications:

- *Motor Control
- *Air Conditioners/ Washing Machines
- *General Purpose Inverters
- *Micro/Mini Inverter Drives

Description

The IRS213(0, 03, 2) are high voltage, high speed power MOSFET and IGBT drivers with three independent high and low side referenced output channels. Proprietary HVIC technology enables ruggedized monolithic construction. Logic inputs are compatible with CMOS or LSTTL outputs, down to 2.5 V logic. A ground-referenced operational amplifier provides analog feedback of bridge current via an external current sense resistor. A current trip function which terminates all six outputs is also derived from this resistor. An open drain FAULT signal indicates if an over-current or undervoltage shutdown has occurred. The output drivers feature a high pulse current buffer stage designed for minimum driver cross-conduction. Propagation delays are matched to simplify use at high frequencies. The floating channels can be used to drive N-channel power MOSFETs or IGBTs in the high side configuration which operates up to 600 V.

Packages

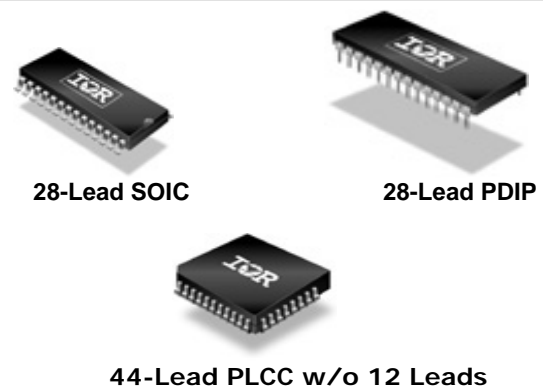

Typical Connection

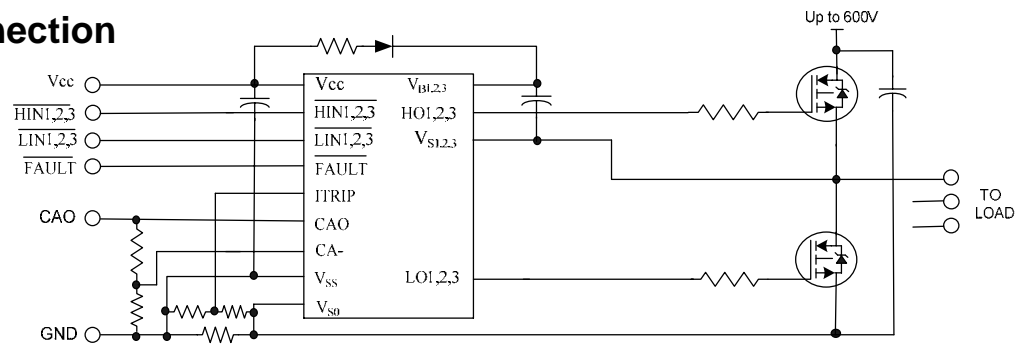

(Refer to Lead Assignments for correct pin configuration). This diagram shows electrical connections only. Please refer to our Application Notes and Design Tips for proper circuit board layout.

Absolute Maximum Ratings

Absolute Maximum Ratings indicate sustained limits beyond which damage to the device may occur. All voltage parameters are absolute voltages referenced to V_{SO} . The thermal resistance and power dissipation ratings are measured under board mounted and still air conditions. Zener clamps are included between V_{CC} & V_{SO} (25 V), V_{CC} & V_{SS} (20V), and V_{Bx} & V_{Sx} (20 V).

Symbol	Definition	Min.	Max.	Units	
$V_{B1,2,3}$	High side floating supply voltage	-0.3	625	V	
$V_{S1,2,3}$	High side floating offset voltage	$V_{B1,2,3} - 20$	$V_{B1,2,3} + 0.3$		
$V_{HO1,2,3}$	High side floating output voltage	$V_{S1,2,3} - 0.3$	$V_{B1,2,3} + 0.3$		
V_{CC}	Low side and logic fixed supply voltage	-0.3	25		
V_{SS}	Logic ground	$V_{CC} - 20$	$V_{CC} + 0.3$		
$V_{LO1,2,3}$	Low side output voltage	-0.3	$V_{CC} + 0.3$		
V_{IN}	Logic input voltage ($\overline{HIN1,2,3}$, $\overline{LIN1,2,3}$ & ITRIP)	$V_{SS} - 0.3$	($V_{SS} + 15$) or ($V_{CC} + 0.3$), whichever is lower		
V_{FLT}	\overline{FAULT} output voltage	$V_{SS} - 0.3$	$V_{CC} + 0.3$		
V_{CAO}	Operational amplifier output voltage	$V_{SS} - 0.3$	$V_{CC} + 0.3$		
V_{CA-}	Operational amplifier inverting input voltage	$V_{SS} - 0.3$	$V_{CC} + 0.3$		
dV_S/dt	Allowable offset supply voltage transient	—	50	V/ns	
P_D	Package power dissipation @ $T_A \leq +25$ °C	(28 lead PDIP)	—	1.5	W
		(28 lead SOIC)	—	1.6	
		(44 lead PLCC)	—	2.0	
$R_{th,JA}$	Thermal resistance, junction to ambient	(28 lead PDIP)	—	83	°C/W
		(28 lead SOIC)	—	78	
		(44 lead PLCC)	—	63	
T_J	Junction temperature	—	150	°C	
T_S	Storage temperature	-55	150		
T_L	Lead temperature (soldering, 10 seconds)	—	300		

Recommended Operating Conditions

The input/output logic timing diagram is shown in Fig. 1. For proper operation, the device should be used within the recommended conditions. All voltage parameters are absolute voltage referenced to V_{SO} . The V_S offset rating is tested with all supplies biased at a 15 V differential.

Symbol	Definition		Min.	Max.	Units
$V_{B1,2,3}$	High side floating supply voltage	IRS213(0,2)	$V_{S1,2,3} + 10$	$V_{S1,2,3} + 20$	V
		IRS21303	$V_{S1,2,3} + 13$		
$V_{S1,2,3}$	High side floating offset voltage		Note 1	600	
$V_{HO1,2,3}$	High side floating output voltage		$V_{S1,2,3}$	$V_{B1,2,3}$	
V_{CC}	Low side and logic fixed supply voltage	IRS213(0,2)	10	20	
		IRS21303	13		
V_{SS}	Logic ground		-5	5	
$V_{LO1,2,3}$	Low side output voltage		0	V_{CC}	
V_{IN}	Logic input voltage ($\overline{HIN1,2,3}$, $\overline{LIN1,2,3}$ & ITRIP)		V_{SS}	$V_{SS} + 5$	
V_{FLT}	\overline{FAULT} output voltage		V_{SS}	V_{CC}	
V_{CAO}	Operational amplifier output voltage		V_{SS}	$V_{SS} + 5$	
V_{CA-}	Operational amplifier inverting input voltage		V_{SS}	$V_{SS} + 5$	
T_A	Ambient temperature		-40	125	°C

Note 1: Logic operational for V_S of ($V_{SO} - 8$ V) to ($V_{SO} + 600$ V). Logic state held for V_S of ($V_{SO} - 8$ V) to ($V_{SO} - V_{BS}$).
(Please refer to the Design Tip DT97-3 for more details).

Note 2: The CAO pin and all input pins (except CA-) are internally clamped with a 5.2 V zener diode.

Static Electrical Characteristics

V_{BIAS} (V_{CC} , $V_{BS1,2,3}$) = 15 V, $V_{SO1,2,3}$ = V_{SS} and T_A = 25 °C unless otherwise specified. The V_{IN} , V_{TH} , and I_{IN} parameters are referenced to V_{SS} and are applicable to all six logic input leads: $\overline{HIN1,2,3}$ & $\overline{LIN1,2,3}$. The V_O and I_O parameters are referenced to $V_{SO1,2,3}$ and are applicable to the respective output leads: $HO1,2,3$ or $LO1,2,3$.

Symbol	Definition	Min.	Typ.	Max.	Units	Test Conditions		
V_{IH}	Logic "0" input voltage (OUT = LO)	2.2	—	—	V			
V_{IL}	Logic "1" input voltage (OUT = HI)	—	—	0.8				
$V_{IT,TH+}$	ITRIP input positive going threshold	400	490	580	mV			
V_{OH}	High level output voltage, $V_{BIAS} - V_O$	—	—	1	V	$V_{IN} = 0$ V, $I_O = 20$ mA		
V_{OL}	Low level output voltage, V_O	—	—	400	mV	$V_{IN} = 5$ V, $I_O = 20$ mA		
I_{LK}	Offset supply leakage current	—	—	50	μ A	$V_B = V_S = 600$ V		
I_{QBS}	Quiescent V_{BS} supply current	—	30	70		$V_{IN} = 0$ V		
I_{QCC}	Quiescent V_{CC} supply current	—	3	5	μ A			
I_{IN+}	Logic "1" input bias current (OUT = HI)	—	300	400			μ A	
I_{IN-}	Logic "0" input bias current (OUT = LO)	—	220	300	$V_{IN} = 5$ V			
I_{ITRIP+}	"High" ITRIP bias current	—	5	10	nA	ITRIP = 5 V		
I_{ITRIP-}	"Low" ITRIP bias current	—	—	100		ITRIP = 0 V		
V_{BSUV+}	V_{BS} supply undervoltage positive going threshold	IRS213(0,2)	7.5	8.35	9.2	V		
		IRS21303	11	—	13			
V_{BSUV-}	V_{BS} supply undervoltage negative going threshold	IRS213(0,2)	7.1	7.95	8.8			
		IRS21303	9	—	11			
V_{CCUV+}	V_{CC} supply undervoltage positive going threshold	IRS213(0,2)	8.3	9	9.7			
		IRS21303	11	—	13			
V_{CCUV-}	V_{CC} supply undervoltage negative going threshold	IRS213(0,2)	8	8.7	9.4			
		IRS21303	9	—	11			
V_{CCUVH}	Hysteresis	IRS213(0,2)	—	0.3	—			
		IRS21303	—	2	—			
V_{BSUVH}	Hysteresis	IRS213(0,2)	—	0.4	—			
		IRS21303	—	2	—			
$R_{on,FLT}$	\overline{FAULT} low on-resistance	—	55	75	Ω			
I_{O+}	Output high short circuit pulsed current	200	250	—	mA			$V_O = 0$ V, $V_{IN} = 0$ V $PW \leq 10$ μ s
I_{O-}	Output low short circuit pulsed current	420	500	—		$V_O = 15$ V, $V_{IN} = 5$ V $PW \leq 10$ μ s		
V_{OS}	Operational amplifier input offset voltage	—	—	10	mV	$V_{SO} = V_{CA-} = 0.2$ V		
I_{CA-}	CA- input bias current	—	—	50	nA	$V_{CA-} = 2.5$ V		
CMRR	Operational amplifier common mode rejection ratio	TBD	80	—	dB	$V_{SO} = V_{CA-} = 0.1$ V & 1.1 V		
PSRR	Operational amplifier power supply rejection ratio	TBD	75	—		$V_{SO} = V_{CA-} = 0.2$ V $V_{CC} = 10$ V & 20 V		
$V_{OH,AMP}$	Operational amplifier high level output voltage	4.9	5.2	5.4	V	$V_{CA-} = 0$ V, $V_{SO} = 1$ V		
$V_{OL,AMP}$	Operational amplifier low level output voltage	—	—	30	mV	$V_{CA-} = 1$ V, $V_{SO} = 0$ V		

Static Electrical Characteristics - (Continued)

V_{BIAS} (V_{CC} , $V_{BS1,2,3}$) = 15 V, $V_{SO1,2,3}$ = V_{SS} and T_A = 25 °C unless otherwise specified. The V_{IN} , V_{TH} , and I_{IN} parameters are referenced to V_{SS} and are applicable to all six logic input leads: $HIN1,2,3$ & $LIN1,2,3$. The V_O and I_O parameters are referenced to $V_{SO1,2,3}$ and are applicable to the respective output leads: $HO1,2,3$ or $LO1,2,3$.

Symbol	Definition	Min.	Typ.	Max.	Units	Test Conditions
$I_{SRC,AMP}$	Operational amplifier output source current	4	7	—	mA	$V_{CA-} = 0\text{ V}$, $V_{SO} = 1\text{ V}$ $V_{CAO} = 4\text{ V}$
$I_{SNK,AMP}$	Operational amplifier output sink current	1	2.1	—		$V_{CA-} = 1\text{ V}$, $V_{SO} = 0\text{ V}$ $V_{CAO} = 2\text{ V}$
$I_{O+,AMP}$	Operational amplifier output high short circuit current	—	10	—		$V_{CA-} = 0\text{ V}$, $V_{SO} = 5\text{ V}$ $V_{CAO} = 0\text{ V}$
$I_{O-,AMP}$	Operational amplifier output low short circuit current	—	4	—		$V_{CA-} = 5\text{ V}$, $V_{SO} = 0\text{ V}$ $V_{CAO} = 5\text{ V}$

Dynamic Electrical Characteristics

V_{BIAS} (V_{CC} , $V_{BS1,2,3}$) = 15 V, $V_{SO1,2,3}$ = V_{SS} , C_L = 1000 pF, T_A = 25 °C unless otherwise specified.

Symbol	Definition	Min.	Typ.	Max.	Units	Test Conditions
t_{on}	Turn-on propagation delay	400	500	700	ns	$V_{S1,2,3} = 0\text{ V to }600\text{ V}$
t_{off}	Turn-off propagation delay	400	500	700		
t_r	Turn-on rise time	—	80	125		
t_f	Turn-off fall time	—	35	55		
t_{trip}	ITRIP to output shutdown propagation delay	400	660	920		
t_{bl}	ITRIP blanking time	—	400	—		
t_{flt}	ITRIP to FAULT indication delay	350	550	870		
$t_{flt, in}$	Input filter time (all six inputs)	—	325	—		
t_{fltclr}	LIN1,2,3 to FAULT clear time IRS213(0,2) LIN1,2,3 & HIN1,2,3 to FAULT clear time IRS21303	5300	8500	13700		
DT	Deadtime	IRS2130	1300	2000		
		IRS213(2,03)	500	700	1100	
SR+	Operational amplifier slew rate (+)	5	10	—	V/μs	1 V input step
SR-	Operational amplifier slew rate (-)	2.4	3.2	—		

NOTE: For high side PWM, HIN pulse width must be $\geq 1.5\ \mu\text{s}$.

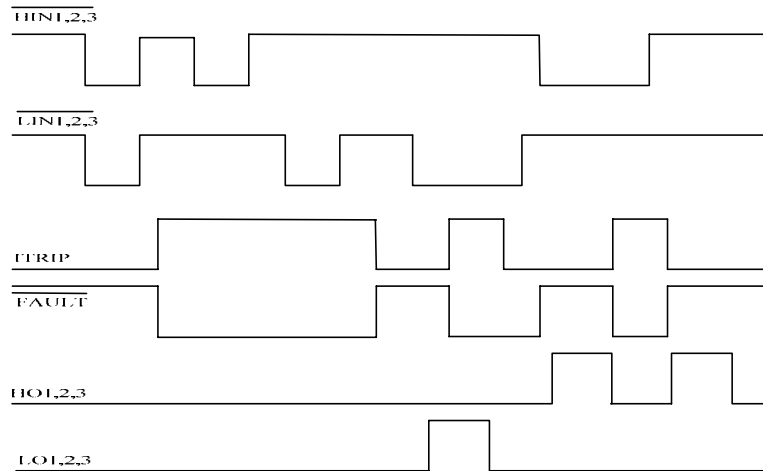

Fig. 1. Input/Output Timing Diagram

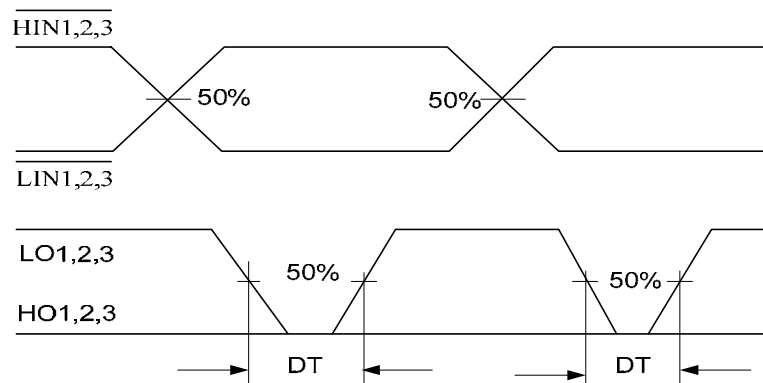

Fig. 2. Deadtime Waveform Definitions

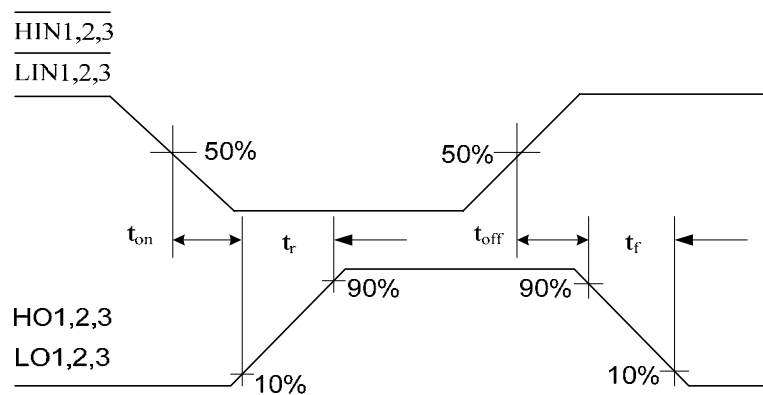

Fig. 3. Input/Output Switching Time Waveform Definitions

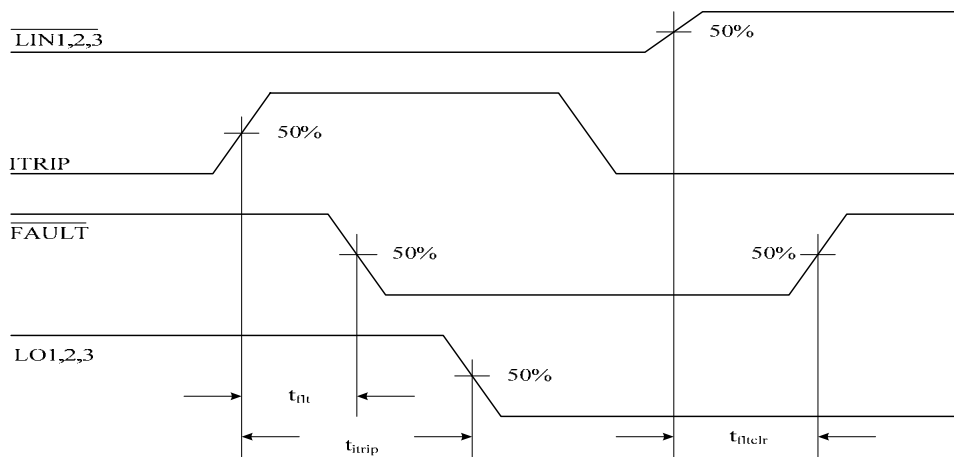

Fig. 4. Overcurrent Shutdown Switching Time Waveform Definitions

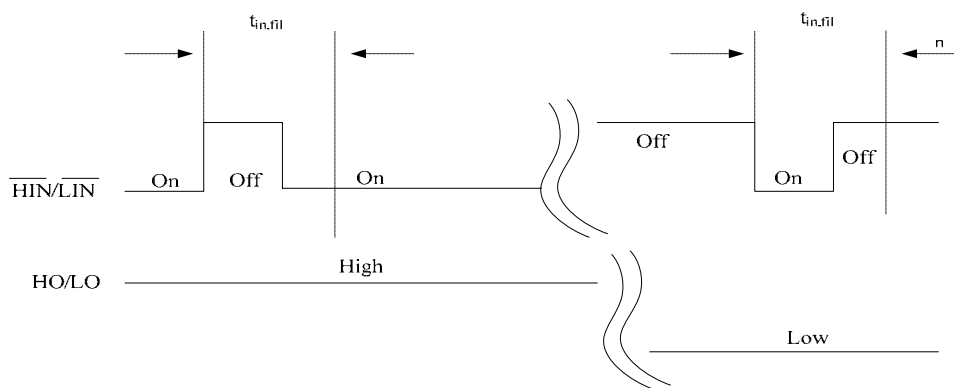

Fig. 5. Input Filter Function

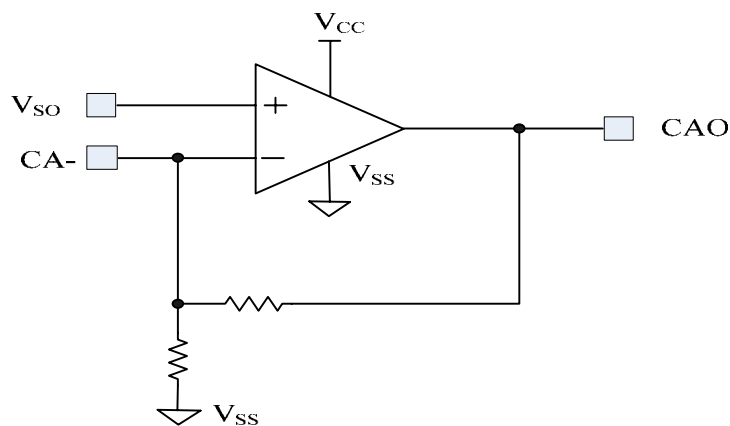
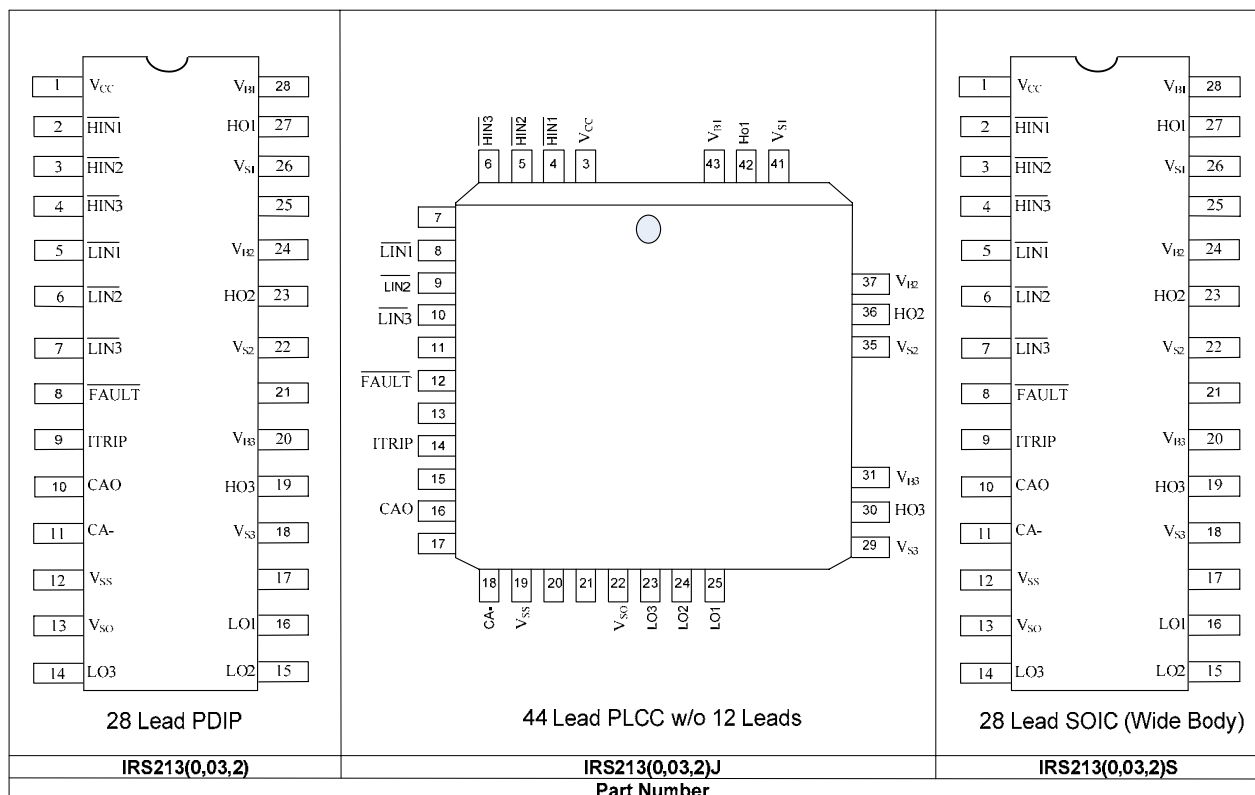

Fig. 6. Diagnostic Feedback Operational Amplifier Circuit

Lead Definitions

Symbol	Description
HIN1,2,3	Logic input for high side gate driver outputs (HO1,2,3), out of phase
LIN1,2,3	Logic input for low side gate driver output (LO1,2,3), out of phase
FAULT	Indicates over-current or undervoltage lockout (low side) has occurred, negative logic
V _{CC}	Low side and logic fixed supply
ITRIP	Input for over-current shutdown
CAO	Output of current amplifier
CA-	Negative input of current amplifier
V _{SS}	Logic ground
V _{B1,2,3}	High side floating supply
HO1,2,3	High side gate drive output
V _{S1,2,3}	High side floating supply return
LO1,2,3	Low side gate drive output
V _{SO}	Low side return and positive input of current amplifier

Lead Assignments



Functional Block Diagram

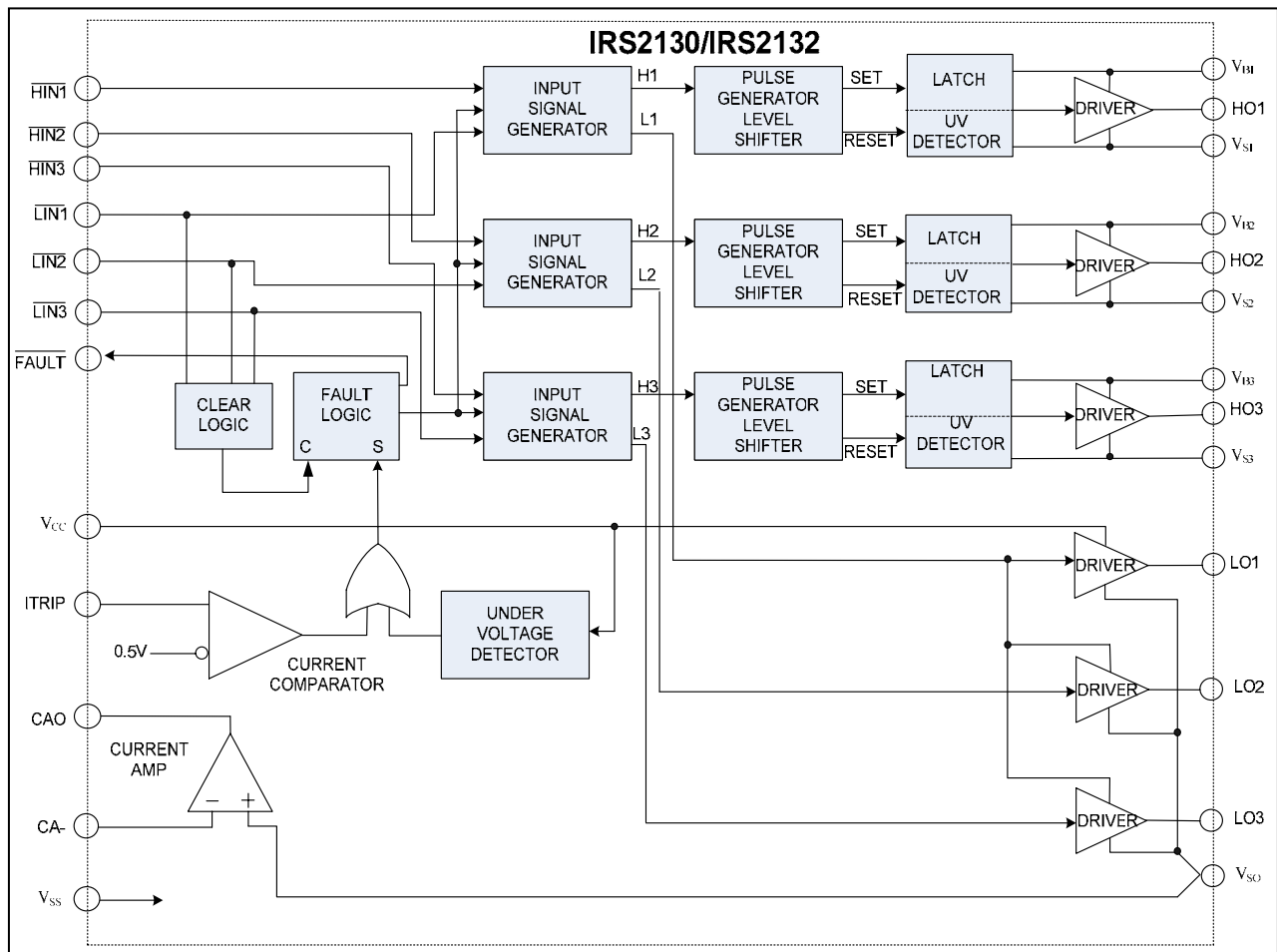

Functional Block Diagram

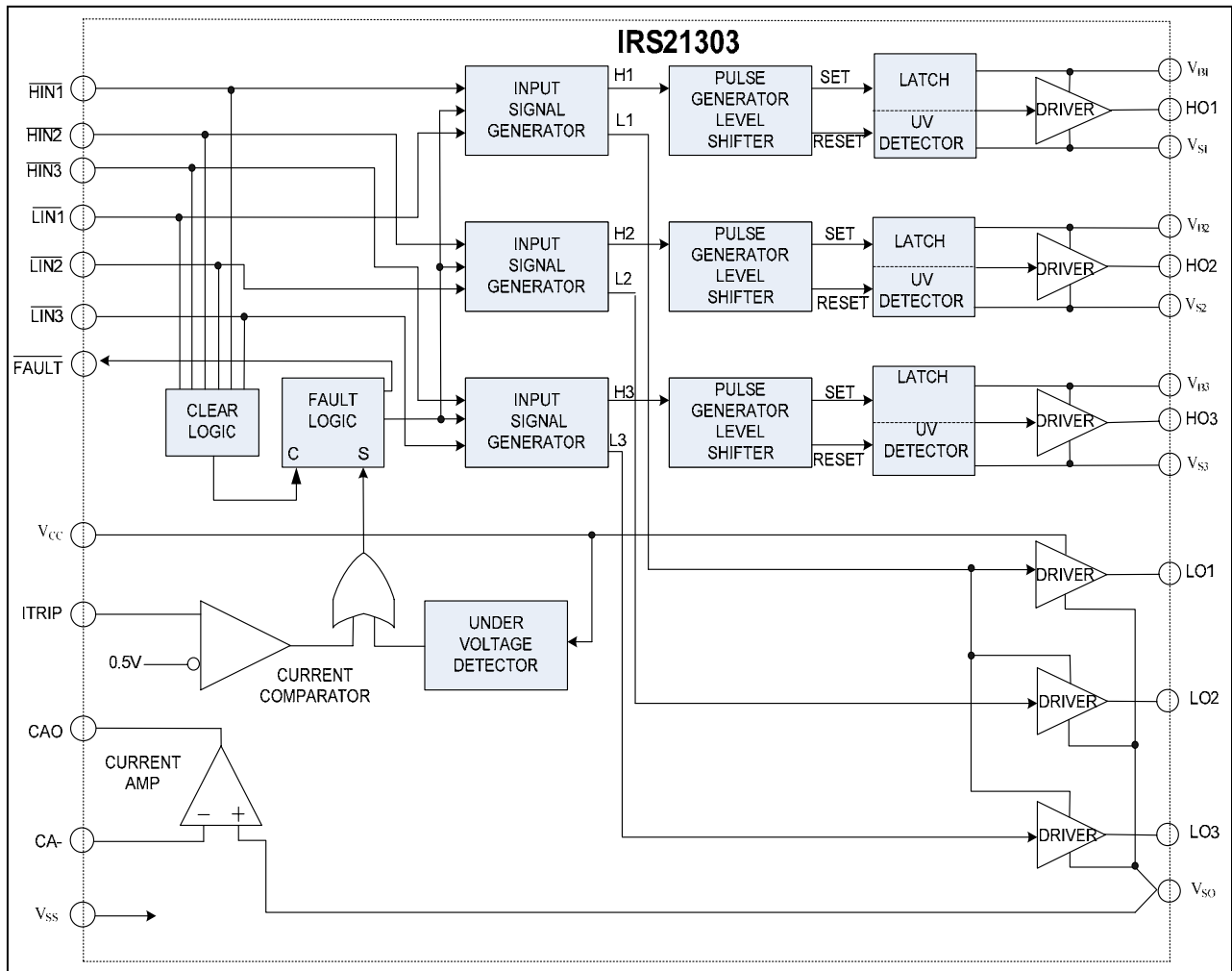

1 PCB Layout Tips

1.1 Distance from H to L Voltage

The IRS213(0,03,2)J package lacks some pins (see page 8) in order to maximizing the distance between the high voltage and low voltage pins. It's strongly recommended to place the components tied to the floating voltage in the respective high voltage portions of the device ($V_{B1,2,3}$, $V_{S1,2,3}$) side.

1.2 Ground Plane

To minimize noise coupling the ground plane must not be placed under or near the high voltage floating side.

1.3 Gate Drive Loops

Current loops behave like an antenna able to receive and transmit EM noise (see Fig. 7). In order to reduce EM coupling and improve the power switch turn on/off performances, gate drive loops must be reduced as much as possible. Moreover, current can be injected inside the gate drive loop via the IGBT collector-to-gate parasitic capacitance. The parasitic auto-inductance of the gate loop contributes to develop a voltage across the gate-emitter increasing the possibility of self turn-on effect.

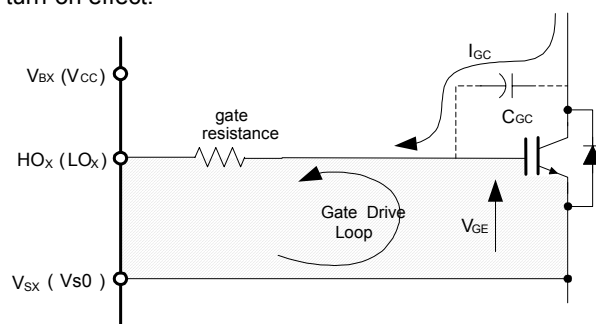

Fig. 7. Antenna Loops

1.4 Supply Capacitors

Supply capacitors must be placed as close as possible to the device pins (V_{CC} and V_{SS} for the ground tied supply, V_B and V_S for the floating supply) in order to minimize parasitic inductance/resistance.

1.5 Routing and Placement

Power stage PCB parasitic may generate dangerous voltage transients for the gate driver and the control logic. In particular it's recommended to limit phase voltage negative transients.

In order to avoid such undervoltage it is highly recommended to minimize high side emitter to low side collector distance and low side emitter to negative bus rail stray inductance. See DT04-4 at www.irf.com for more detailed information.

Figures 8-38 provide information on the experimental performance of the IRS2130S HVIC. The line plotted in each figure is generated from actual lab data. A large number of individual samples were tested at three temperatures (-40 °C, 25 °C, and 125 °C) in order to generate the experimental (Exp.) curve. The line labeled Exp. consist of three data points (one data point at each of the tested temperatures) that have been connected together to illustrate the understood trend. The individual data points on the curve were determined by calculating the averaged experimental value of the parameter (for a given temperature).

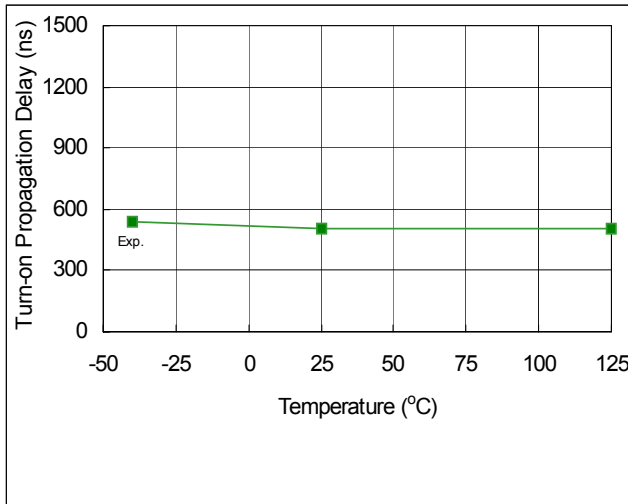

Fig. 8. Turn-On Propagation Delay vs. Temperature

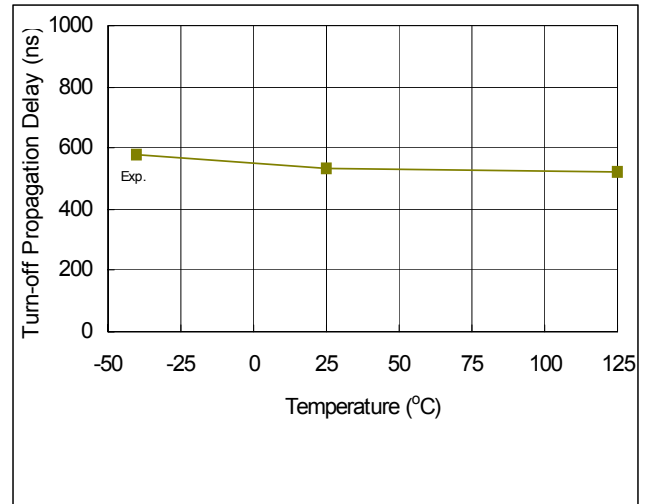

Fig. 9. Turn-Off Propagation Delay vs. Temperature

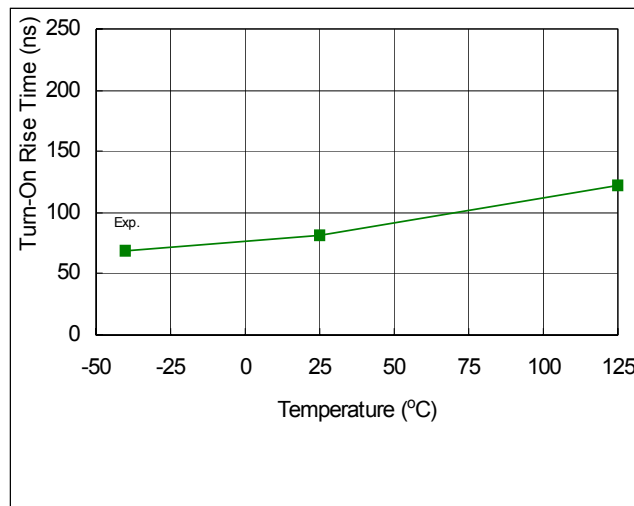

Fig. 10. Turn-On Rise Time vs. Temperature

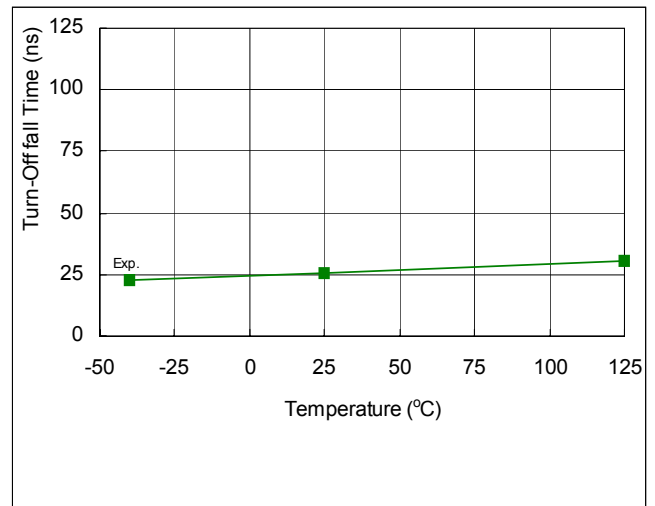

Fig. 11. Turn-Off Fall Time vs. Temperature

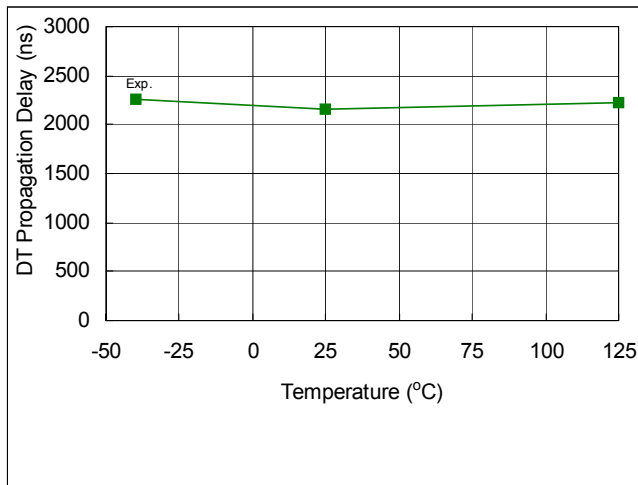

Fig. 12. DT Propagation Delay vs. Temperature

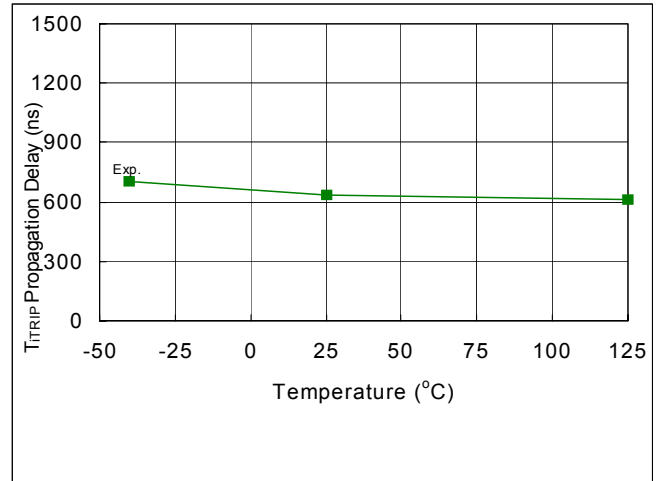

Fig. 13. T_{ITRIP} Propagation Delay vs. Temperature

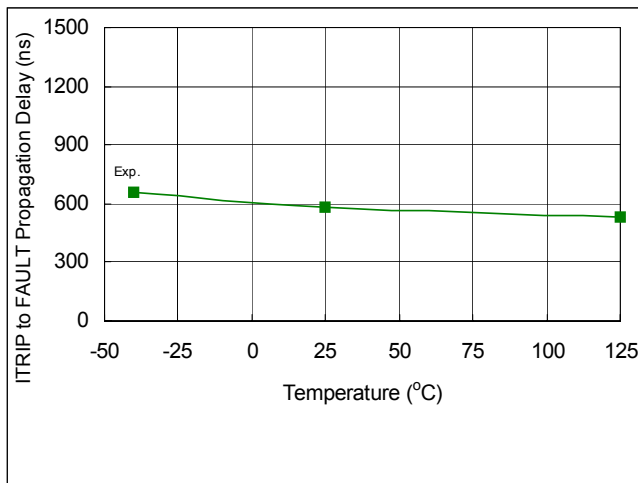

Fig. 14. ITRIP to FAULT Propagation Delay vs. Temperature

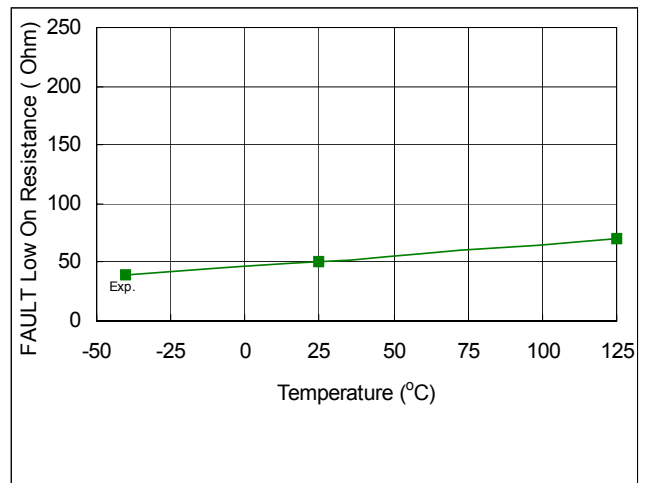

Fig.15. FAULT Low On Resistance vs. Temperature

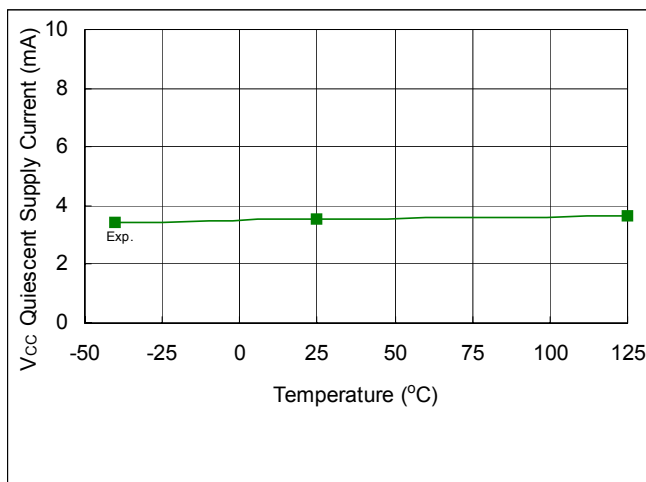

Fig. 16. V_{CC} Quiescent Current vs. Temperature

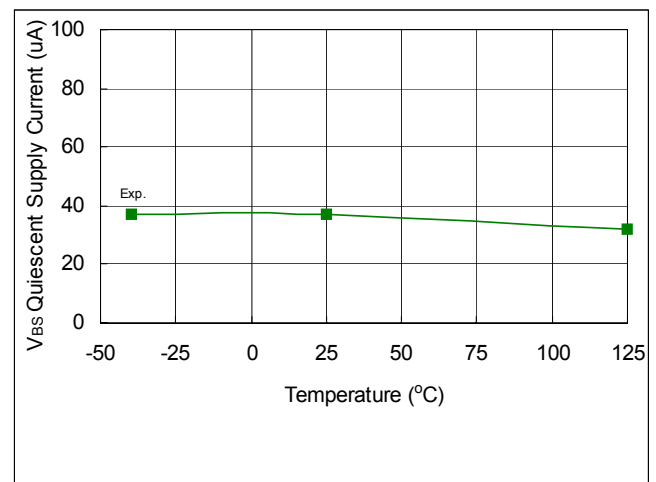

Fig. 17. V_{BS} Quiescent Current vs. Temperature

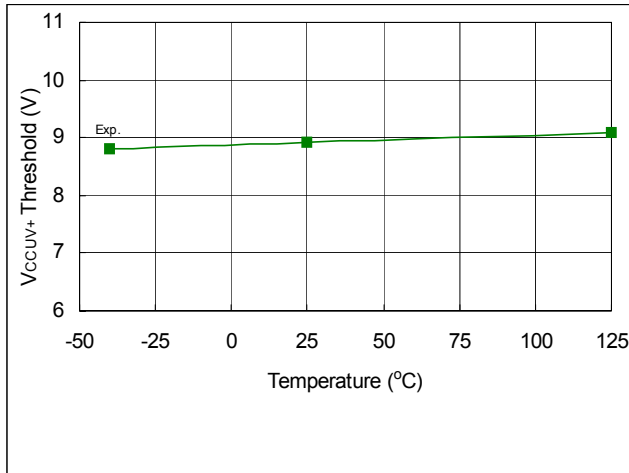

Fig. 18. V_{CCUV+} Threshold vs. Temperature

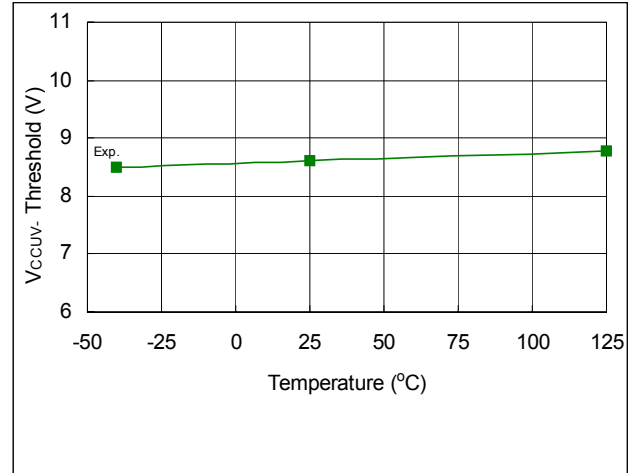

Fig. 19. V_{CCUV-} Threshold vs. Temperature

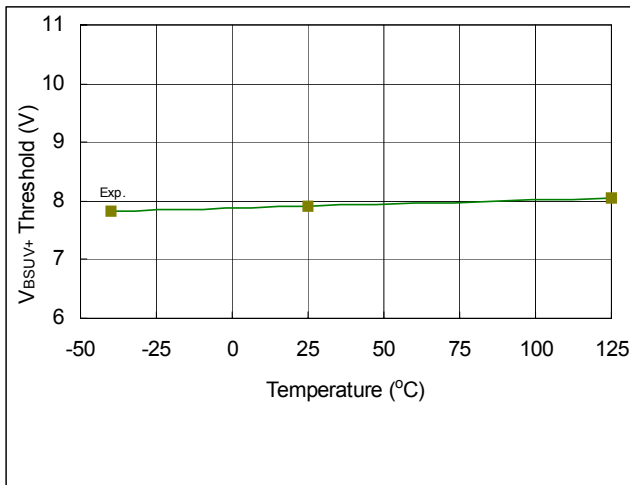

Fig. 20. V_{BSUV+} Threshold vs. Temperature

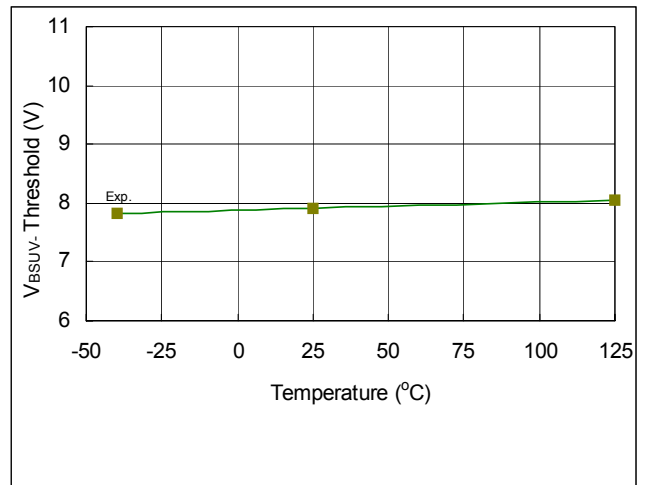

Fig. 21. V_{BSUV-} Threshold vs. Temperature

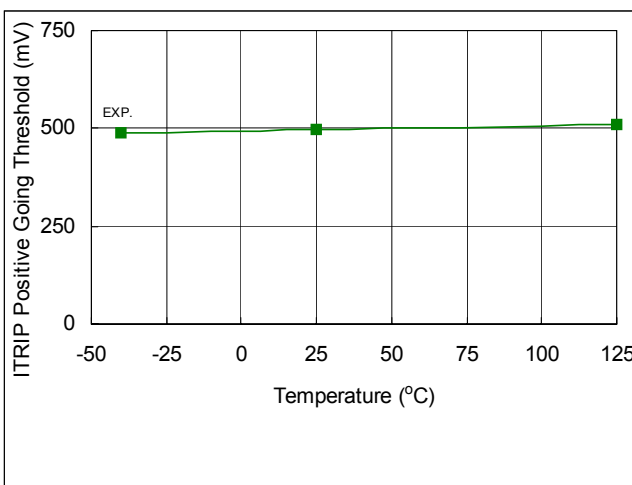

Fig. 22. ITRIP Positive Going Threshold vs. Temperature

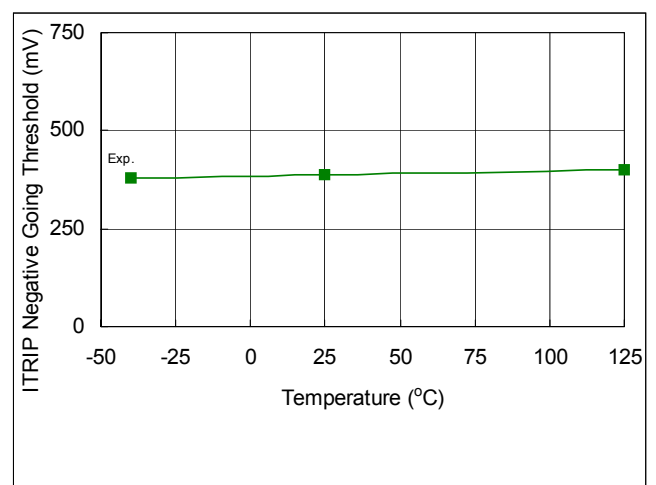

Fig. 23. ITRIP Negative Going Threshold vs. Temperature

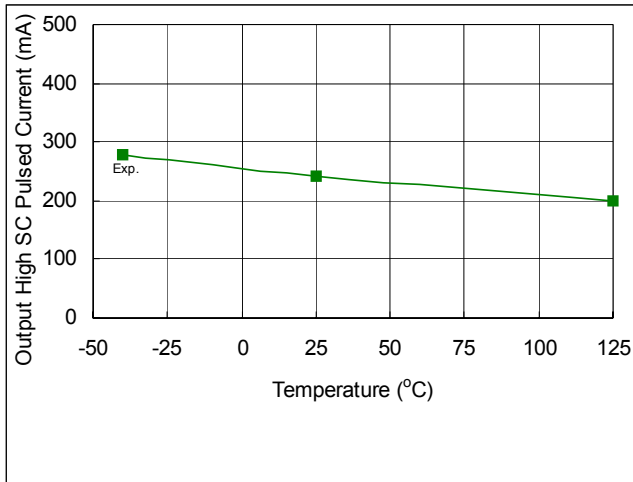

Fig. 24. Output High Short Circuit Pulsed Current vs. Temperature

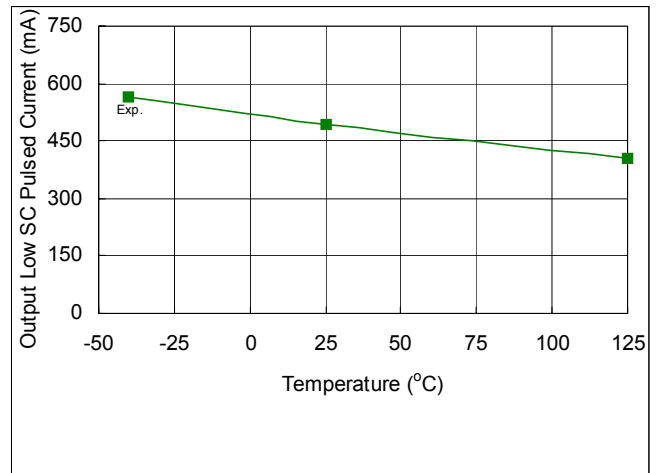

Fig. 25. Output Low Short Circuit Pulsed Current vs. Temperature

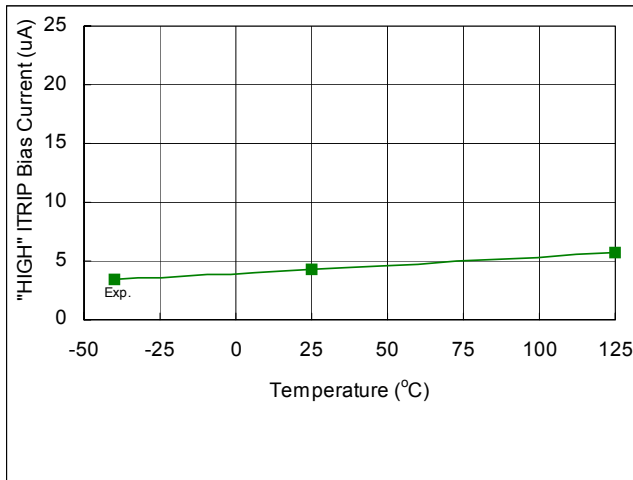

Fig. 26. "High" ITRIP Bias Current vs. Temperature

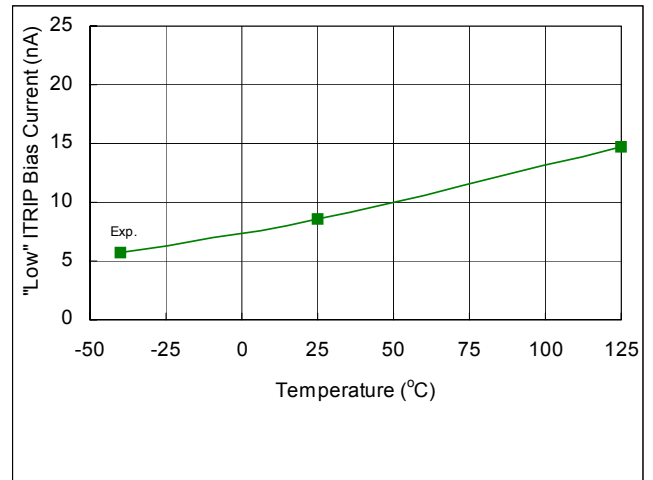

Fig. 27. "Low" ITRIP Bias Current vs. Temperature

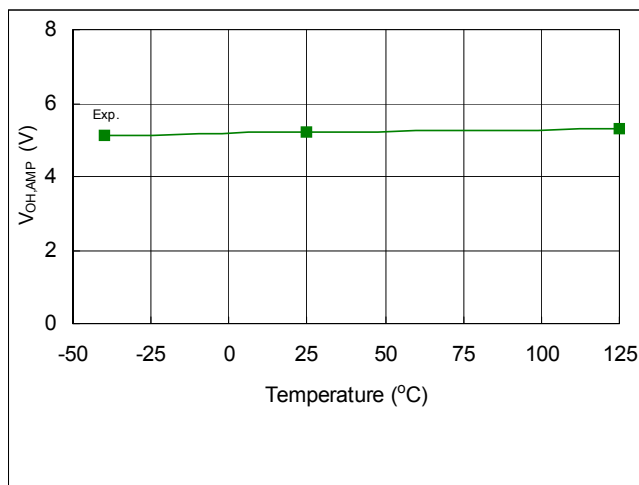

Fig. 28. V_{OH,AMP} vs. Temperature

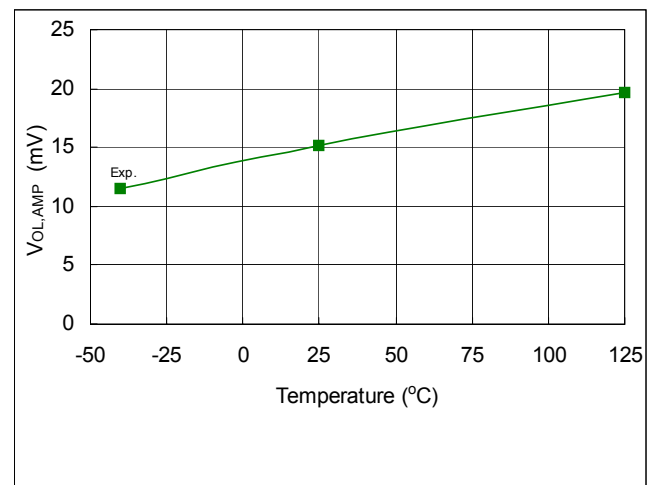

Fig. 29. V_{OL,AMP} vs. Temperature

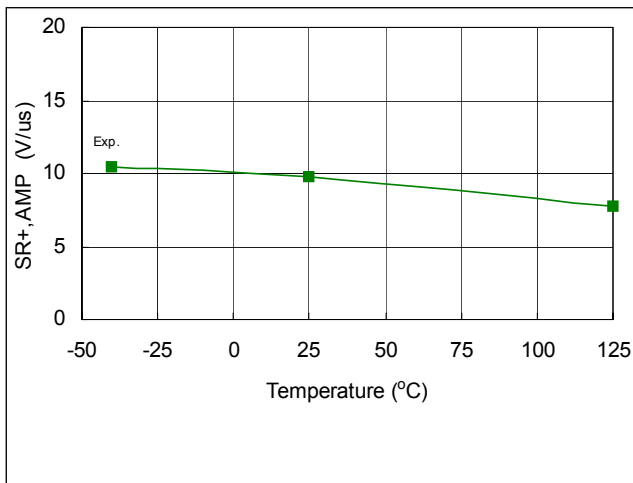

Fig. 30. SR+,AMP vs. Temperature

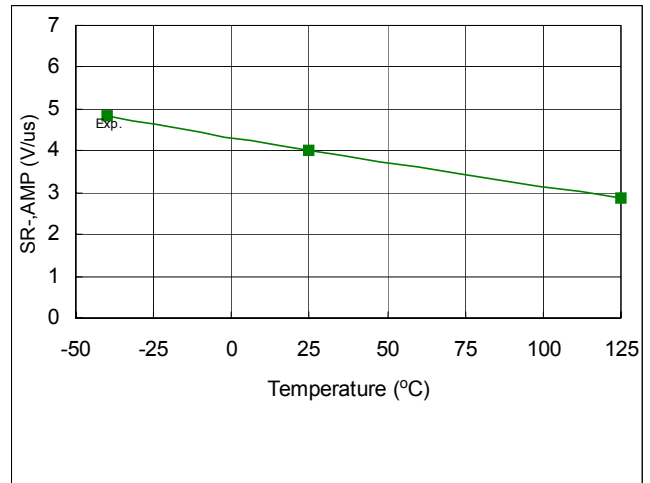

Fig. 31. SR-,AMP vs. Temperature

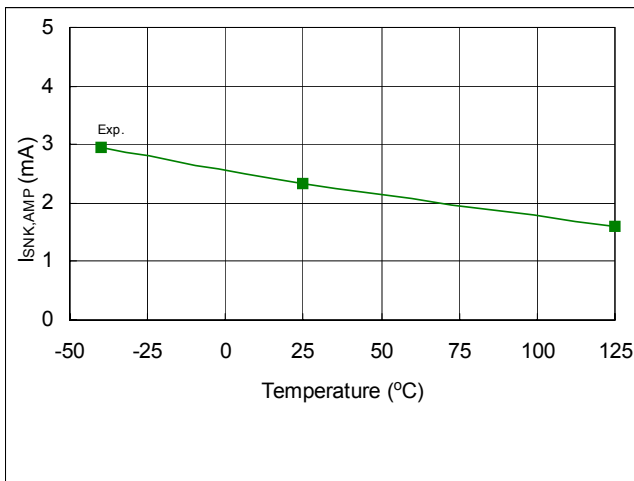

Fig. 32. ISNK,AMP vs. Temperature

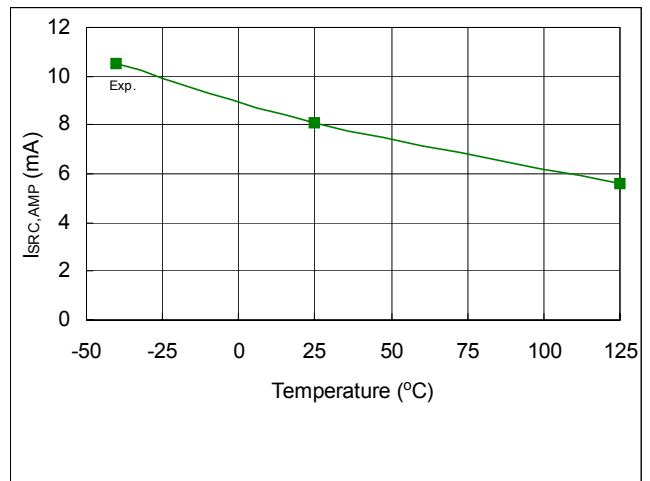

Fig. 33. ISRC,AMP vs. Temperature

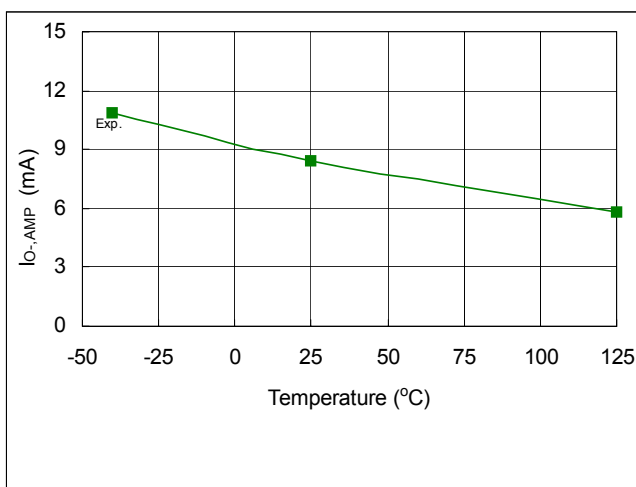

Fig. 34. IO-,AMP vs. Temperature

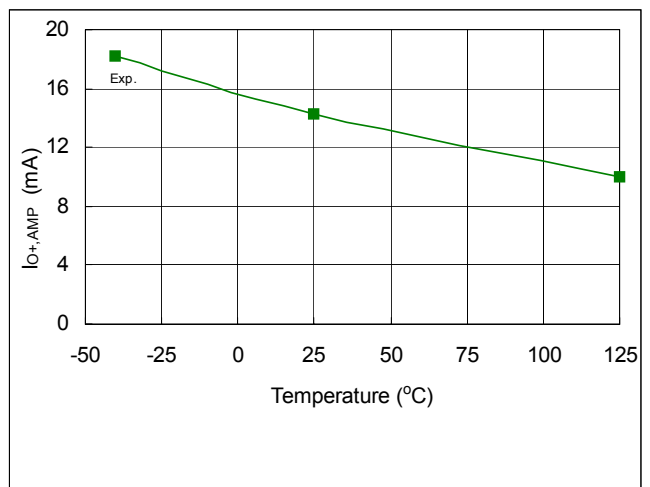

Fig. 35. IO+,AMP vs. Temperature

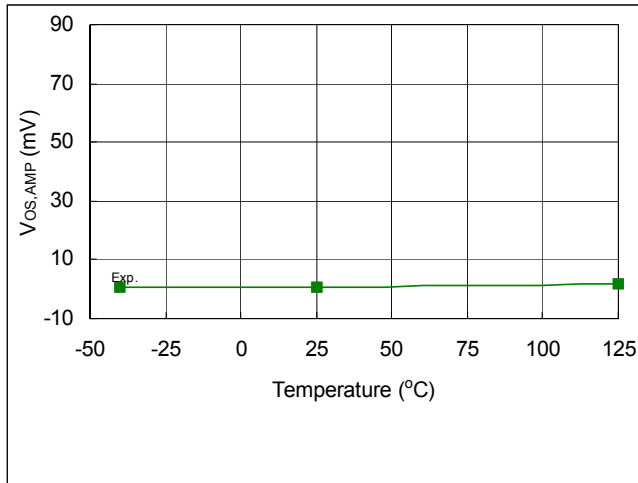

Fig. 36. V_{OS,AMP} vs. Temperature

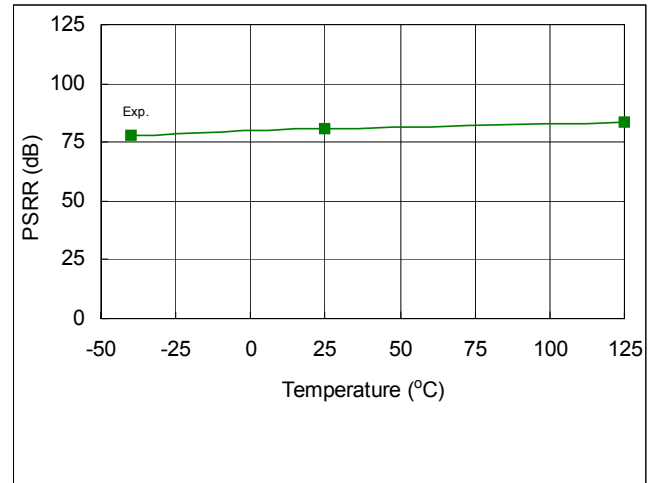

Fig. 37. PSRR vs. Temperature

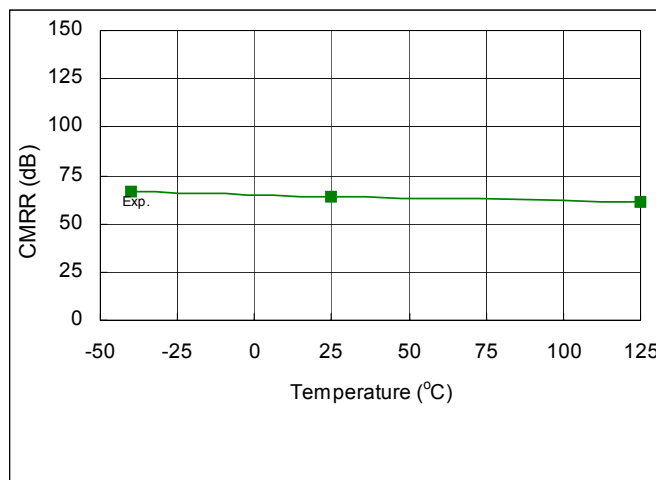
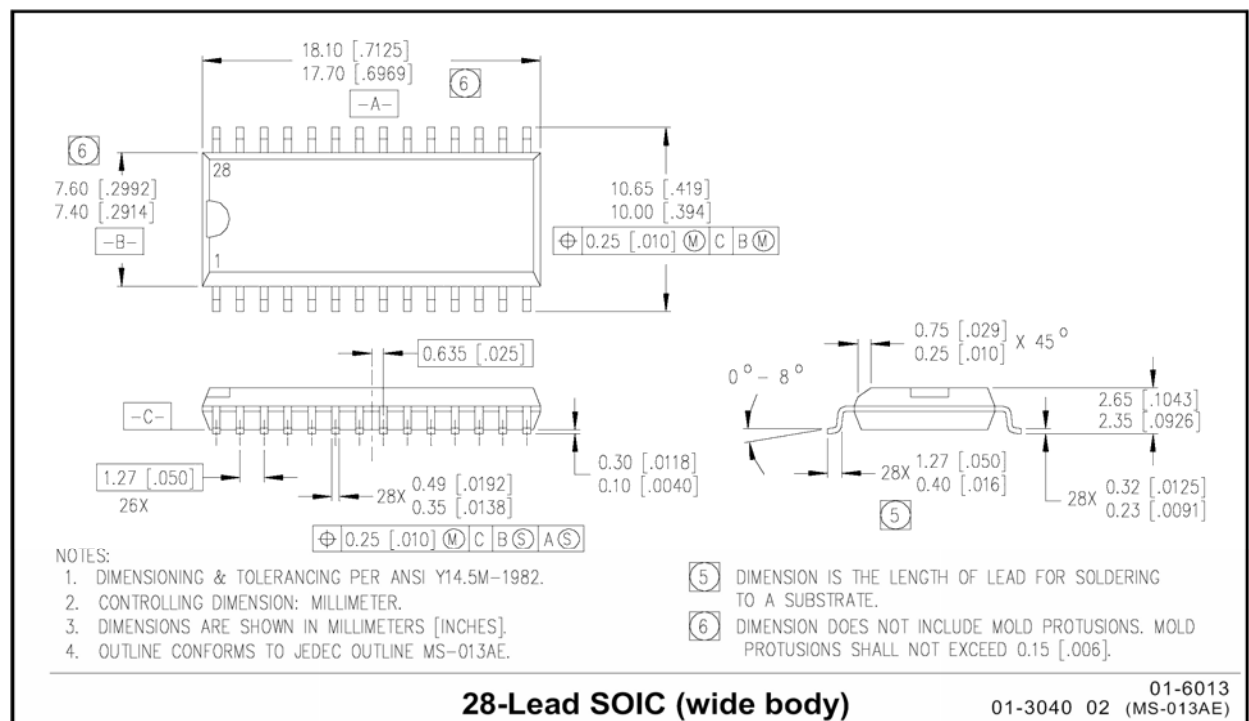
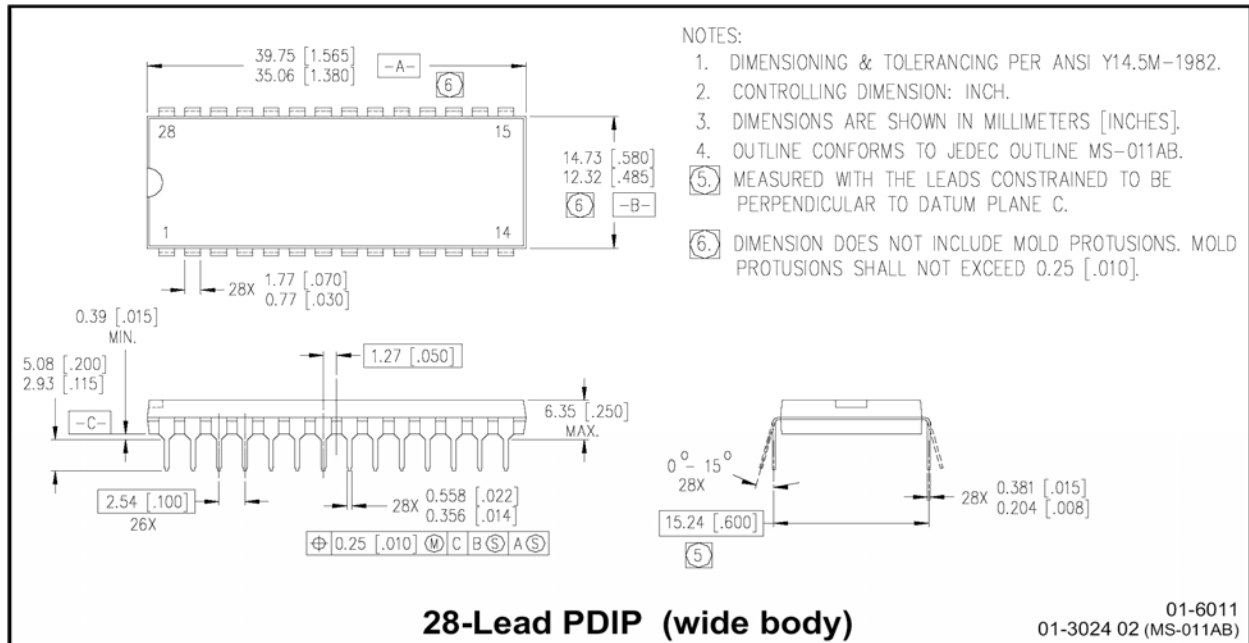
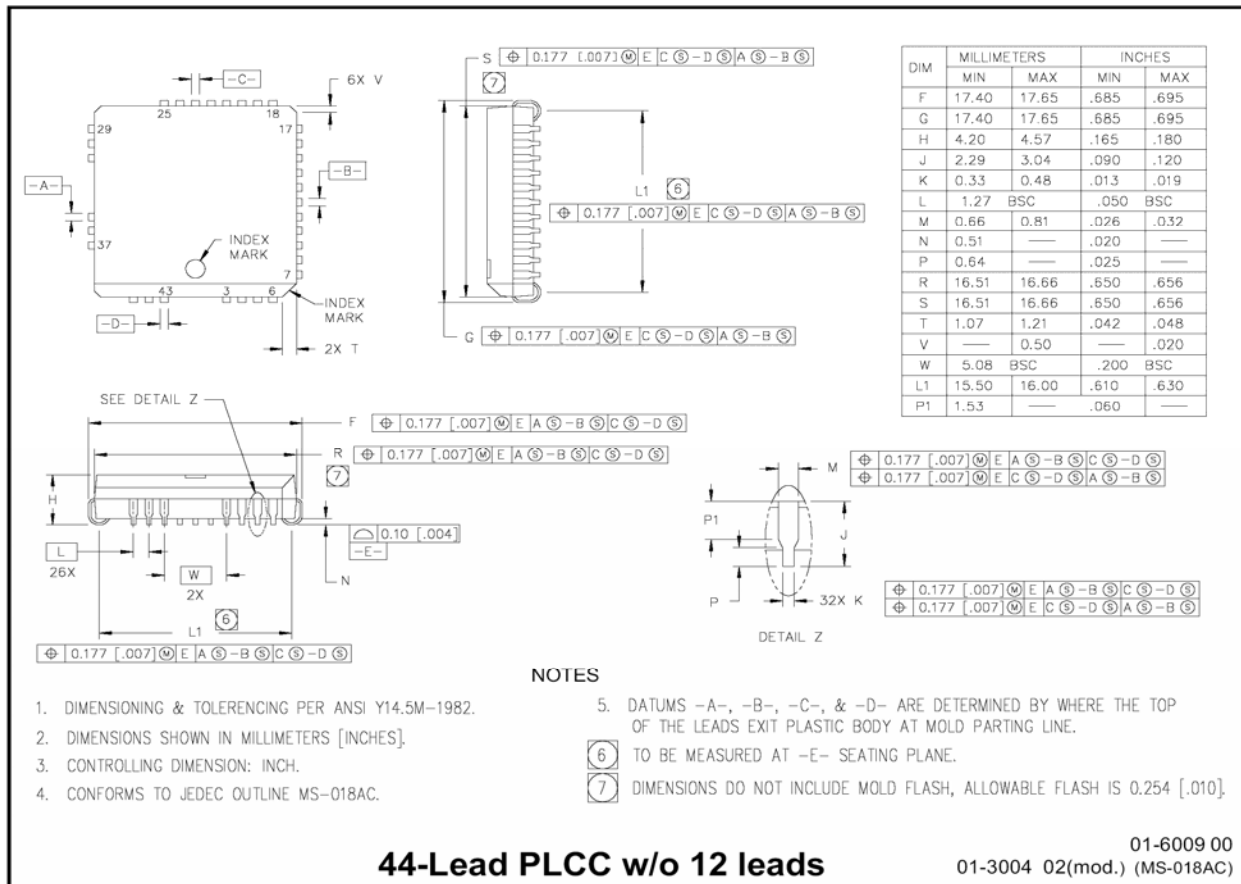

Fig. 38. CMRR vs. Temperature

Case Outlines



Case Outlines



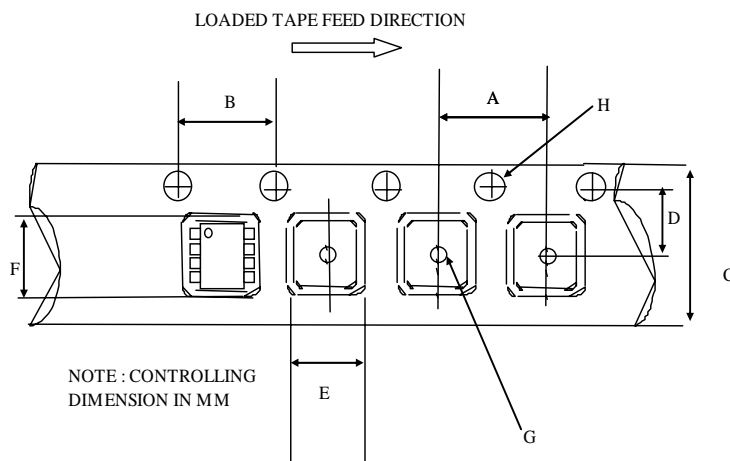

CARRIER TAPE DIMENSION FOR 28SOICW

Code	Metric		Imperial	
	Min	Max	Min	Max
A	11.90	12.10	0.468	0.476
B	3.90	4.10	0.153	0.161
C	23.70	24.30	0.933	0.956
D	11.40	11.60	0.448	0.456
E	10.80	11.00	0.425	0.433
F	18.20	18.40	0.716	0.724
G	1.50	n/a	0.059	n/a
H	1.50	1.60	0.059	0.062

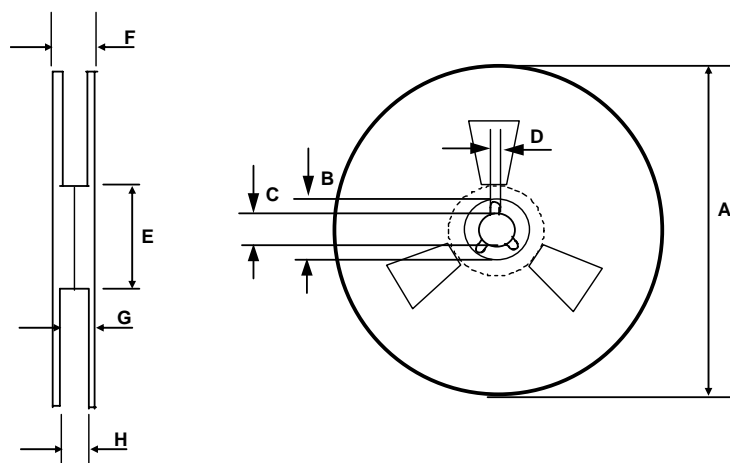

REEL DIMENSIONS FOR 28SOICW

Code	Metric		Imperial	
	Min	Max	Min	Max
A	329.60	330.25	12.976	13.001
B	20.95	21.45	0.824	0.844
C	12.80	13.20	0.503	0.519
D	1.95	2.45	0.767	0.096
E	98.00	102.00	3.858	4.015
F	n/a	30.40	n/a	1.196
G	26.50	29.10	1.04	1.145
H	24.40	26.40	0.96	1.039

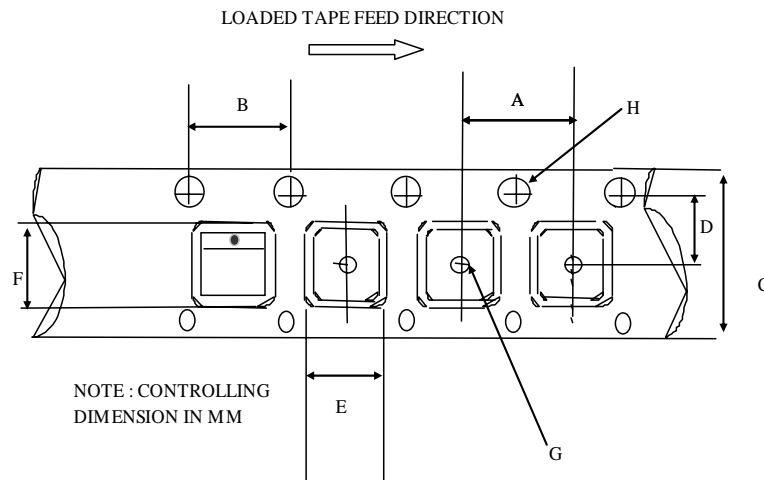

CARRIER TAPE DIMENSION FOR 44PLCC

Code	Metric		Imperial	
	Min	Max	Min	Max
A	23.90	24.10	0.94	0.948
B	3.90	4.10	0.153	0.161
C	31.70	32.30	1.248	1.271
D	14.10	14.30	0.555	0.562
E	17.90	18.10	0.704	0.712
F	17.90	18.10	0.704	0.712
G	2.00	n/a	0.078	n/a
H	1.50	1.60	0.059	0.062

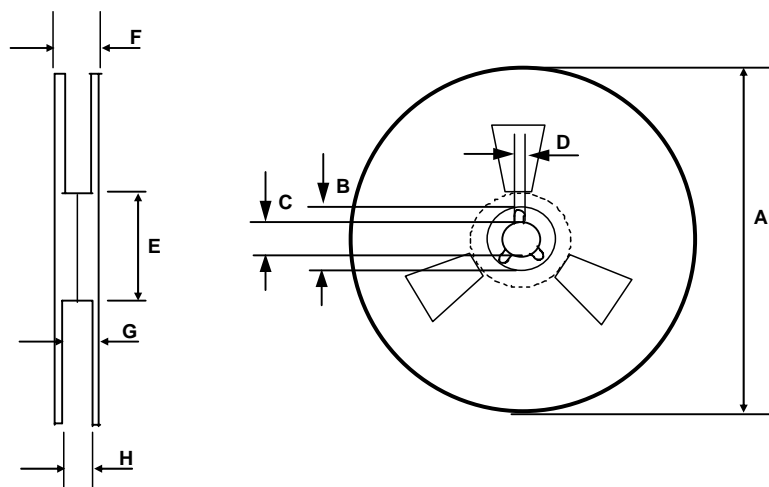

REEL DIMENSIONS FOR 44PLCC

Code	Metric		Imperial	
	Min	Max	Min	Max
A	329.60	330.25	12.976	13.001
B	20.95	21.45	0.824	0.844
C	12.80	13.20	0.503	0.519
D	1.95	2.45	0.767	0.096
E	98.00	102.00	3.858	4.015
F	n/a	38.4	n/a	1.511
G	34.7	35.8	1.366	1.409
H	32.6	33.1	1.283	1.303

LEAD-FREE PART MARKING INFORMATION

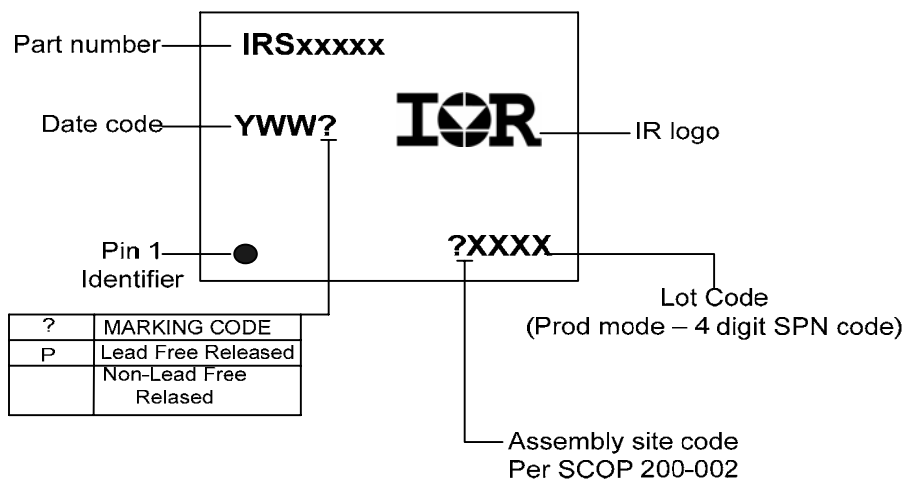

ORDER INFORMATION

- 28-Lead PDIP IRS2130PbF
- 28-Lead PDIP IRS21303PbF
- 28-Lead PDIP IRS2132PbF
- 28-Lead SOIC IRS2130SPbF
- 28-Lead SOIC IRS21303SPbF
- 28-Lead SOIC IRS2132SPbF
- 44-Lead PLCC IRS2132JPbF
- 44-Lead PLCC IRS21303JPbF
- 44-Lead PLCC IRS2132JPbF

- 28-Lead SOIC Tape & Reel IRS2130STRPbF
- 28-Lead SOIC Tape & Reel IRS21303STRPbF
- 28-Lead SOIC Tape & Reel IRS2132STRPbF
- 44-Lead PLCC Tape & Reel IRS2130JTRPbF
- 44-Lead PLCC Tape & Reel IRS21303JTRPbF
- 44-Lead PLCC Tape & Reel IRS2132JTRPbF