

# IPS5751/IPS5751S

## FULLY PROTECTED HIGH SIDE POWER MOSFET SWITCH

### Features

- Over temperature protection (with auto-restart)
- Over current shutdown
- Active clamp
- E.S.D protection
- Status feedback
- Open load detection
- Logic ground isolated from power ground

### Description

The IPS5751/IPS5751S are fully protected five terminal high side switch with built in short circuit, over-temperature, ESD protection, inductive load capability and diagnostic feedback. The over-current protection latches off the device if the output current exceeds  $I_{shutdown}$ . It can be reset by turning the input pin low. The over-temperature protection turns off the high side switches if the junction temperature exceeds  $T_{shutdown}$ . It will automatically restart after the junction has cooled  $7^{\circ}\text{C}$  below  $T_{shutdown}$ . A diagnostic pin is provided for status feedback of over-current, over-temperature and open load detection. The double level shifter circuitry allows large offsets between the logic ground and the load ground.

### Product Summary

$R_{ds(on)}$	25m $\Omega$ (max)
$V_{clamp}$	50V
$I_{shutdown}$	35A
$I_{open\ load}$	1A

### Truth Table

Op. Conditions	In	Out	Dg
Normal	H	H	H
Normal	L	L	H
Open load	H	H	L
Open load	L	X	H
Over current	H	L (latched)	L
Over current	L	L	H
Over-temperature	H	L (cycling)	L (cycling)
Over-temperature	L	L	H

### Typical Connection

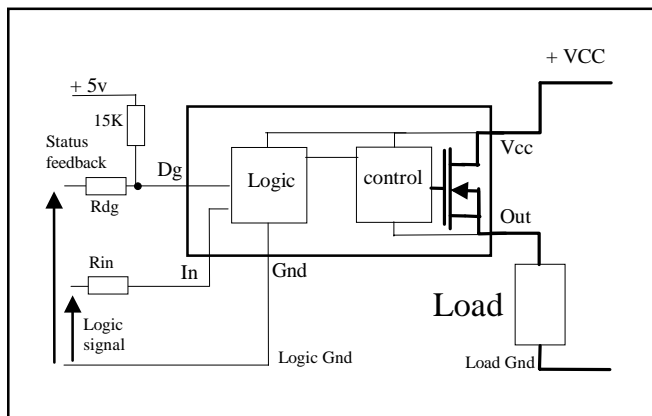

### Packages

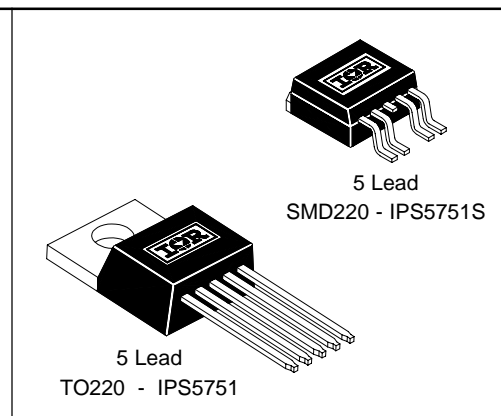

# IPS5751/IPS5751S

International  
IR Rectifier

## Absolute Maximum Ratings

Absolute maximum ratings indicate sustained limits beyond which damage to the device may occur. All voltage parameters are referenced to GROUND lead. ( $T_{Ambient} = 25^{\circ}C$  unless otherwise specified).

Symbol	Parameter	Min.	Max.	Units	Test Conditions
$V_{out}$	Maximum output voltage	$V_{CC}-45$	$V_{CC}+0.3$	V	
$V_{offset}$	Maximum logic ground to load ground offset	$V_{CC}-45$	$V_{CC}+0.3$		
$V_{in}$	Maximum Input voltage	-0.3	5.5		
$I_{in, max}$	Maximum IN current	-5	10	mA	
$V_{dg}$	Maximum diagnostic output voltage	-0.3	5.5	V	
$I_{dg, max}$	Maximum diagnostic output current	-1	10	mA	
$I_{sd cont.}$	Diode max. continuous current <sup>(1)</sup>			A	
	(Rth=60°C/W) IPS5751	—	2.8		
	(Rth=80°C/W) IPS5751S	—	2.2		
$I_{sd pulsed}$	Diode max. pulsed current <sup>(1)</sup>	—	45		
ESD1	Electrostatic discharge voltage (Human Body)	—	4	kV	C=100pF, R=1500Ω,
ESD2	Electrostatic discharge voltage (Machine Model)	—	0.5		C=200pF, R=0Ω, L=10μH
$P_d$	Maximum power dissipation <sup>(1)</sup>			W	
	(Rth=60°C/W) IPS5751	—	2		
	(Rth=80°C/W) IPS5751S	—	1.56		
$T_j max.$	Max. storage & operating junction temp.	-40	+150	°C	
$T_{lead}$	Lead temperature (soldering 10 seconds)	—	300		
$V_{cc max.}$	Maximum Vcc voltage	—	45	V	

## Thermal Characteristics

Symbol	Parameter	Min.	Typ.	Max.	Units	Test Conditions
$R_{th 1}$	Thermal resistance junction to case	—	2	—	°C/W	TO-220
$R_{th 2}$	Thermal resistance junction to ambient	—	55	—		
$R_{th 1}$	Thermal resistance with standard footprint	—	60	—		D <sup>2</sup> PAK (SMD220)
$R_{th 2}$	Thermal resistance with 1" square footprint	—	35	—		
$R_{th 3}$	Thermal resistance junction to case	—	5	—		

(1) Limited by junction temperature (pulsed current limited also by internal wiring)

### Recommended Operating Conditions

These values are given for a quick design. For operation outside these conditions, please consult the application notes.

Symbol	Parameter	Min.	Max.	Units
V <sub>CC</sub>	Continuous V <sub>CC</sub> voltage	5.5	28	V
V <sub>IH</sub>	High level input voltage	4	5.5	
V <sub>IL 1</sub>	Low level input voltage	-0.3	0.9	
I <sub>out</sub>	Continuous output current (T <sub>ambient</sub> = 85°C, T <sub>j</sub> = 125°C, R <sub>th</sub> = 60°C/W) IPS5751	—	4	A
	(T <sub>ambient</sub> = 85°C, T <sub>j</sub> = 125°C, R <sub>th</sub> = 80°C/W) IPS5751S	—	3.5	
I <sub>out</sub> T <sub>c</sub> =85°C	Continuous output current (T <sub>Case</sub> = 85°C, I <sub>N</sub> = 5V, T <sub>j</sub> = 125°C, R <sub>th</sub> = 5°C/W)	—	14	
R <sub>in</sub>	Recommended resistor in series with IN pin	4	6	kΩ
R <sub>dg</sub>	Recommended resistor in series with DG pin	10	20	

### Static Electrical Characteristics

(T<sub>j</sub> = 25°C, V<sub>CC</sub> = 14V unless otherwise specified.)

Symbol	Parameter	Min.	Typ.	Max.	Units	Test Conditions
R <sub>ds(on)</sub> @T <sub>j</sub> =25°C	ON state resistance T <sub>j</sub> = 25°C	—	19	25	mΩ	V <sub>in</sub> = 5V, I <sub>out</sub> = 14A
R <sub>ds(on)</sub> (V <sub>CC</sub> =6V)	ON state resistance @ V <sub>CC</sub> = 6V	—	22	30		V <sub>in</sub> = 5V, I <sub>out</sub> = 7A
R <sub>ds(on)</sub> @T <sub>j</sub> =150°C	ON state resistance T <sub>j</sub> = 150°C	—	32	—		V <sub>in</sub> = 5V, I <sub>out</sub> = 14A
V <sub>CC oper.</sub>	Functional operating range	5.5	—	35	V	
V <sub>clamp 1</sub>	V <sub>CC</sub> to OUT clamp voltage 1	45	49	—		I <sub>d</sub> = 10mA (see Fig.1 & 2)
V <sub>clamp 2</sub>	V <sub>CC</sub> to OUT clamp voltage 2	—	50	60		I <sub>d</sub> = I <sub>shutdown</sub> (see Fig.1 & 2)
V <sub>f</sub>	Body diode forward voltage	—	0.9	1.2		I <sub>d</sub> = 14A, V <sub>in</sub> = 0V
I <sub>out</sub> leakage	Output leakage current	—	10	50	μA	V <sub>out</sub> = 0V, T <sub>j</sub> = 25°C
I <sub>CC off</sub>	Supply current when OFF	—	10	50		V <sub>in</sub> = 0V, V <sub>out</sub> = 0V
I <sub>CC on</sub>	Supply current when ON	—	4.5	10	mA	V <sub>in</sub> = 5V
I <sub>CC ac</sub>	Ripple current when ON (AC RMS)	—	20	—	μA	V <sub>in</sub> = 5V
V <sub>dgl</sub>	Low level diagnostic output voltage	—	0.3	0.45	V	I <sub>dg</sub> = 0.3 mA
I <sub>dg</sub> leakage	Diagnostic output leakage current	—	1.5	10	μA	V <sub>dg</sub> = 4.5V
V <sub>ih</sub>	IN high threshold voltage	—	2.7	3.4	V	
V <sub>il</sub>	IN low threshold voltage	1	2.0	—		
I <sub>in, on</sub>	On state IN positive current	—	30	80	μA	V <sub>in</sub> = 4V
V <sub>CCuv+</sub>	V <sub>CC</sub> UVLO positive going threshold	—	4.7	5.5	V	
V <sub>CCuv-</sub>	V <sub>CC</sub> UVLO negative going threshold	3.0	4.4	—		
I <sub>nhyst.</sub>	Input hysteresis	0.2	0.6	1.5		

# IPS5751/IPS5751S

International  
**IR** Rectifier

## Switching Electrical Characteristics

$V_{CC} = 14V$ , Resistive Load =  $1\Omega$ ,  $T_j = 25^\circ C$ , (unless otherwise specified).

Symbol	Parameter	Min.	Typ.	Max.	Units	Test Conditions
$T_{don}$	Turn-on delay time	—	5	20	$\mu s$	See figure 3
$T_{r1}$	Rise time to $V_{out} = V_{CC} - 5V$	—	4	20		
$T_{r2}$	Rise time from the end of $T_{r1}$ to $V_{out} = 90\%$ of $V_{CC}$	—	65	150		
$dV/dt$ (on)	Turn ON $dV/dt$	—	3	6	$V/\mu s$	
$E_{on}$	Turn ON energy	—	2	—	$mJ$	See figure 4
$T_{doff}$	Turn-off delay time	—	65	150	$\mu s$	
$T_f$	Fall time to $V_{out} = 10\%$ of $V_{CC}$	—	8	20		
$dV/dt$ (off)	Turn OFF $dV/dt$	—	5	10	$V/\mu s$	
$E_{off}$	Turn OFF energy	—	0.75	—	$mJ$	

## Protection Characteristics

Symbol	Parameter	Min.	Typ.	Max.	Units	Test Conditions
$T_{sd+}$	Over-temp. positive going threshold	—	165	—	$^\circ C$	See fig. 2
$T_{sd-}$	Over-temp. negative going threshold	—	158	—	$^\circ C$	See fig. 2
$I_{sd}$	Over-current threshold	22	35	50	A	See fig. 2
$I_{open\ load}$	Open load detection threshold	0.3	1	2	A	
$T_{reset}$	Minimum time to reset protections	—	50	—	$\mu s$	$V_{in} = 0V$
$T_{dg}$	Blanking time before considering $Dg$	—	7	100	$\mu s$	Part turned on with $V_{in} = 5V$

## Functional Block Diagram (All values are typical)

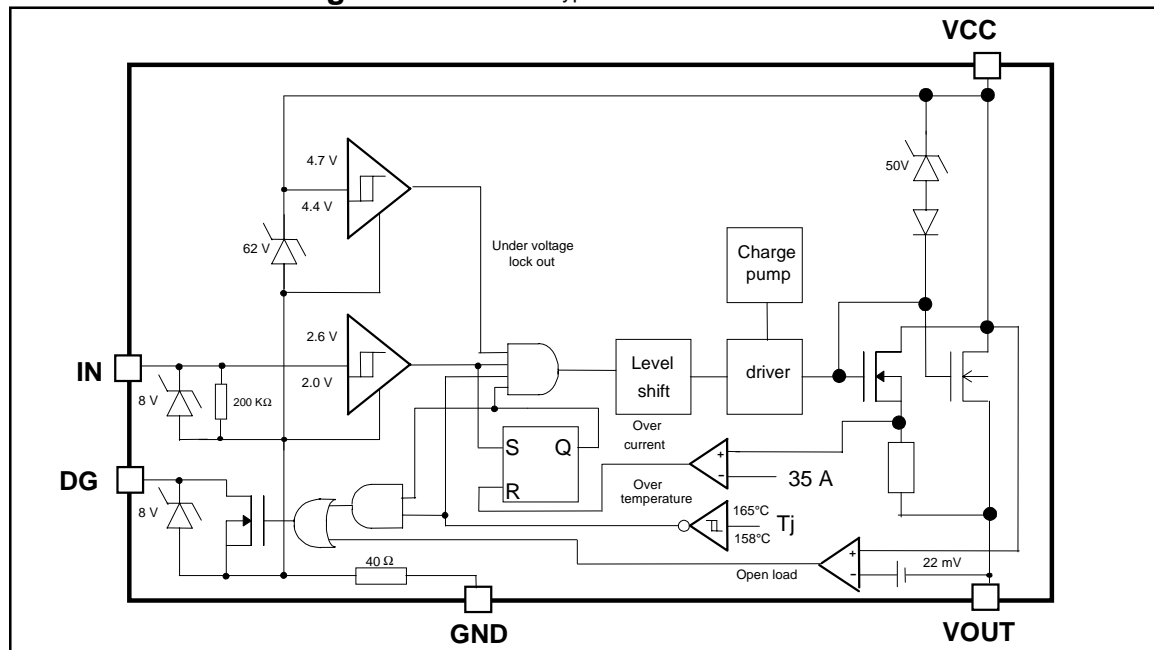

**Lead Assignments**

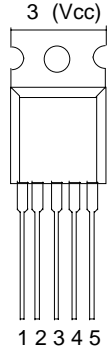
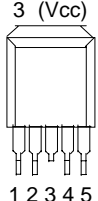
 <p>3 (Vcc)</p> <p>1 2 3 4 5</p> <p>5 Lead - TO220</p>	<p>1 - Ground                  2 - In                  3 - Vcc                  4 - DG                  5 - Out</p>	 <p>3 (Vcc)</p> <p>1 2 3 4 5</p> <p>5 Lead - D<sup>2</sup>PAK (SMD220)</p>
<p><b>IPS5751</b>                  (qualifications based on AEC Q 101)</p>		<p><b>IPS5751S</b>                  (qualifications based on industrial level)</p>
<p><b>Part Number</b></p>		

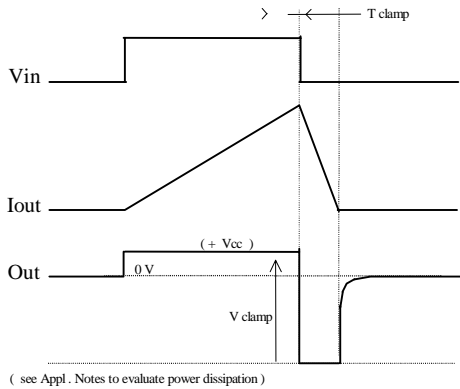

Figure 1 - Active clamp waveforms

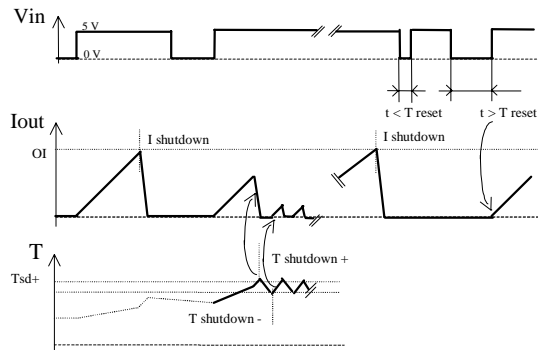

Figure 2 - Protection timing diagram

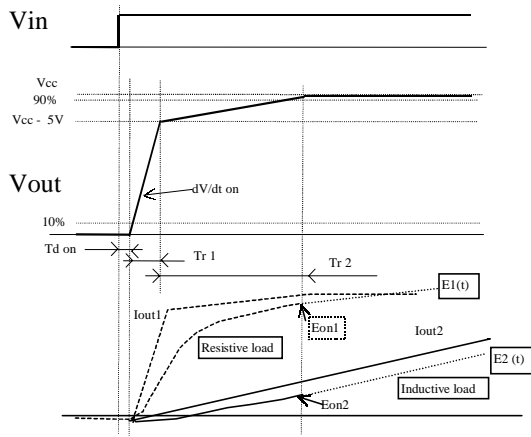

Figure 3 - Switching times definition (turn-on)  
Turn on energy with a resistive or an inductive load

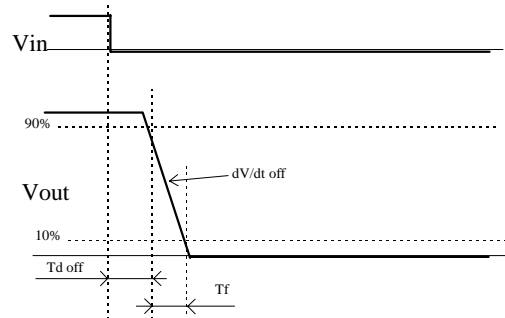

Figure 4 - Switching times definition (turn-off)

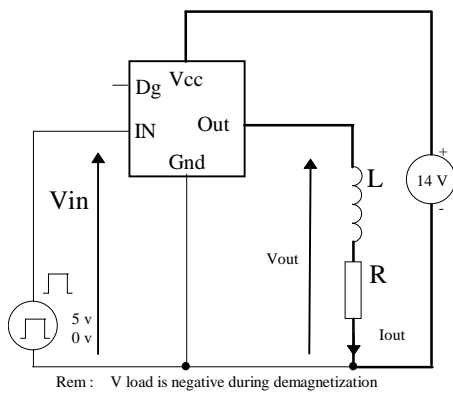

Figure 5 - Active clamp test circuit

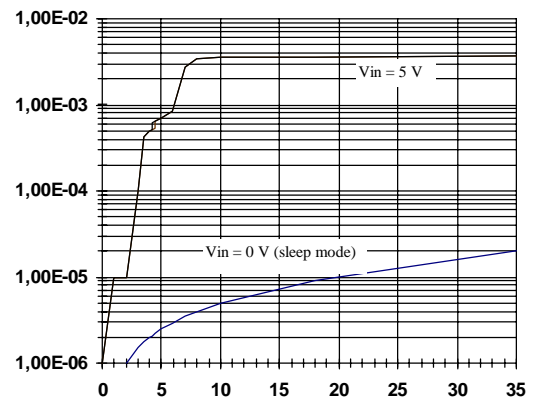

Figure 6 - Icc (mA) Vs Vcc (V)

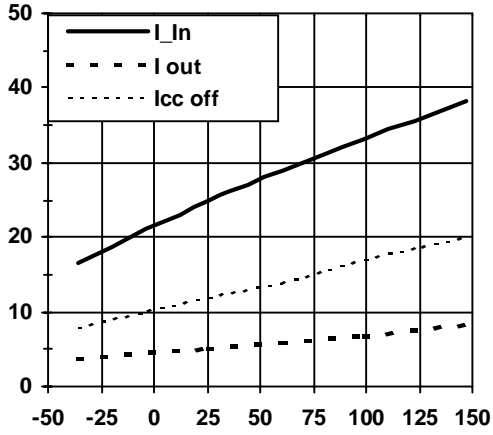

Figure 7 -  $I_{in}$ ,  $I_{out}$  &  $I_{cc\ off}$  ( $\mu A$ ) Vs  $T_j$  (°C)

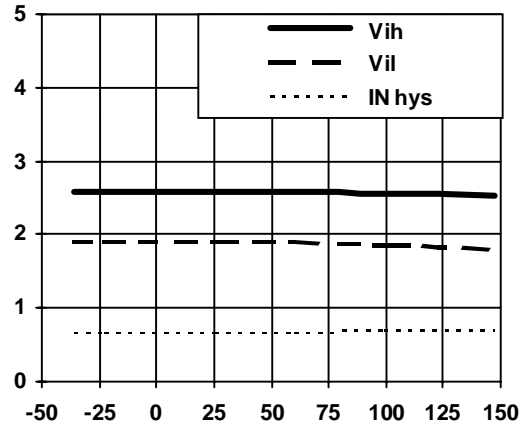

Figure 8 -  $V_{ih}$ ,  $V_{il}$  &  $I_N\ hyst.$  (V) Vs  $T_j$  (°C)

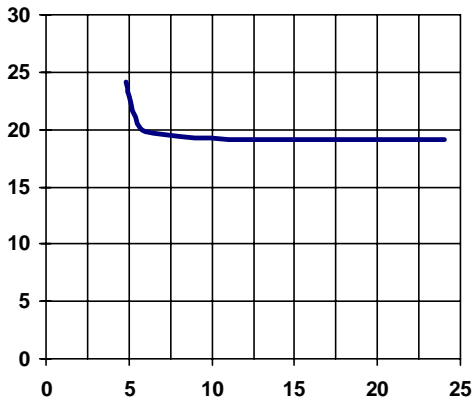

Figure 9 -  $R_{dson}$  ( $m\Omega$ ) vs  $V_{cc}$  (V)

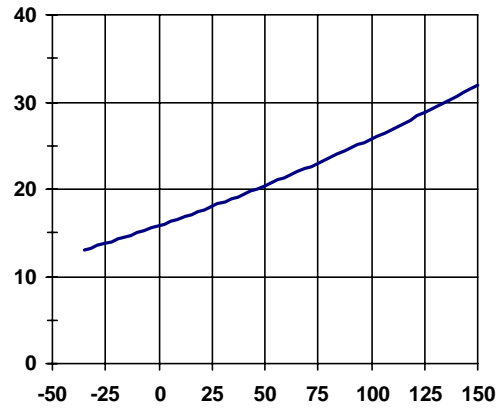

Figure 10 -  $R_{dson}$  ( $m\Omega$ ) vs  $T_j$  (°C)

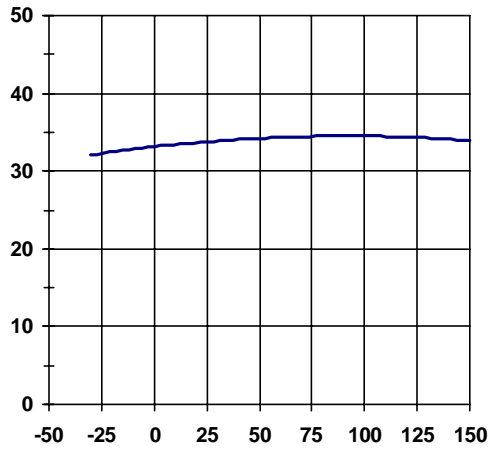

Figure 11 - I shutdown (A) vs Tj (°C)

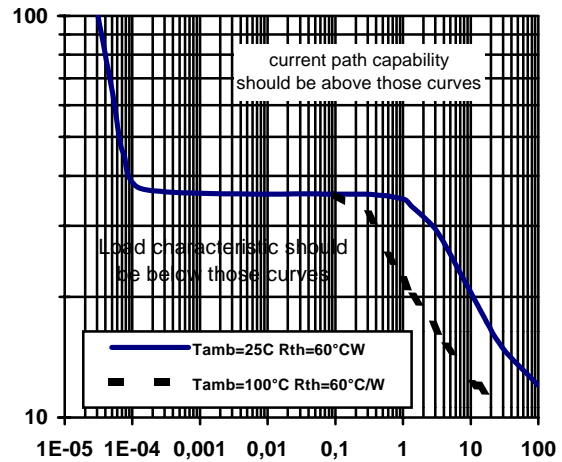

Figure 12 - Protection characteristic - (A) vs (S) \*

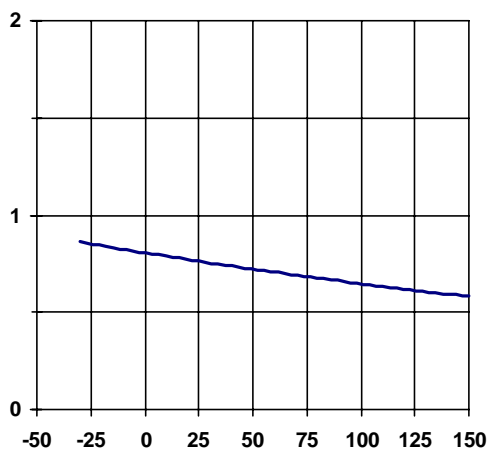

Figure 13 - I open load (A) vs Tj (°C)

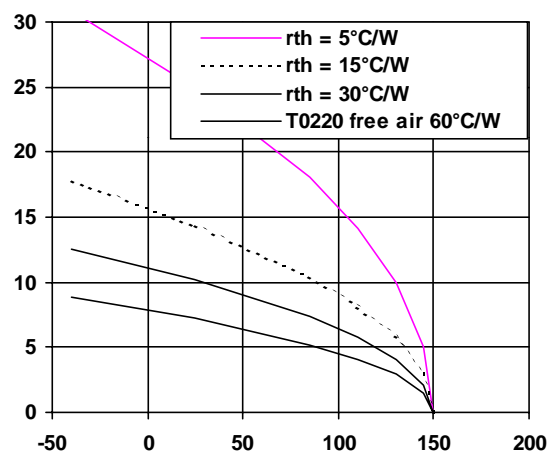

Figure 14 - Max. Cont. Ids (A) Vs Amb. Temperature (°C)

NOTE: \* Over-current protection for less than 1ms and thermal protection for durations higher than 1s.



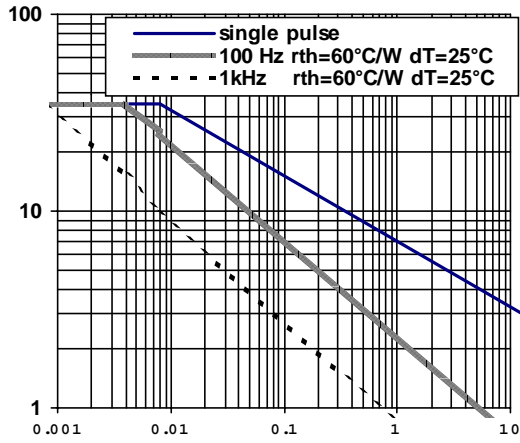

Figure 15 -Max. I clamp ( A ) Vs Inductive Load ( m H )

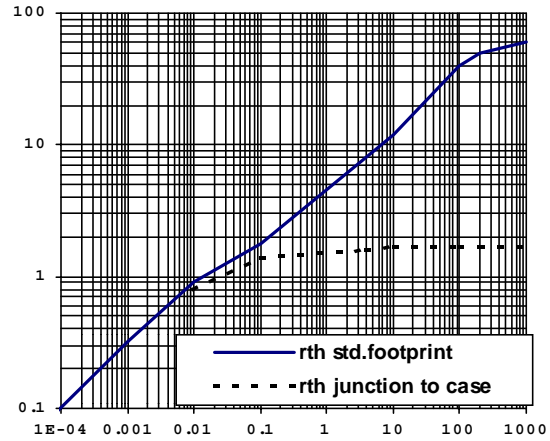

Figure 16 - Transient Rth ( °C/W ) Vs Time ( s )

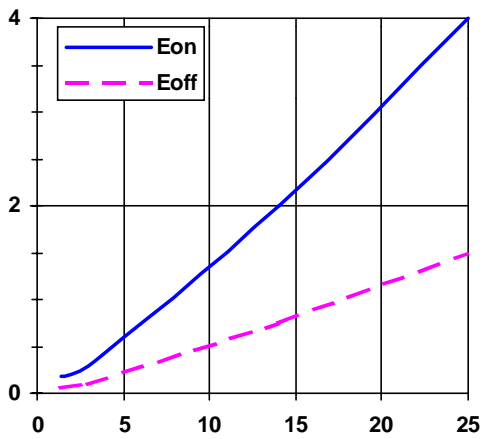

Figure 17 - Eon, Eoff @ Vcc=14V (mJ) vs Iout (A)

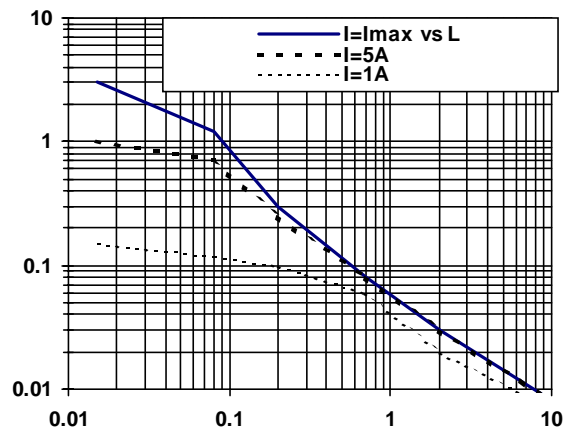
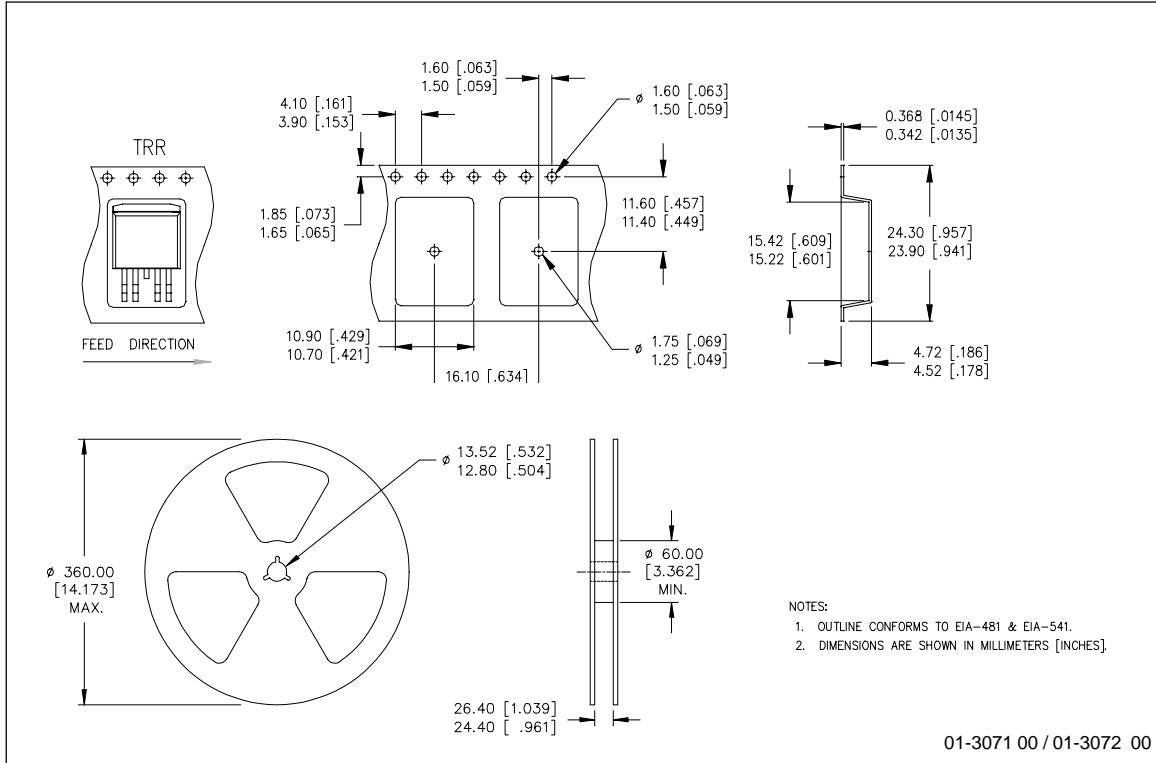

Figure 18 - Eon @ Vcc=14V (mJ) vs Inductance (mH)

# IPS5751/IPS5751S

International  
**IR** Rectifier

## Tape & Reel - D<sup>2</sup>PAK (SMD220) - 5 Lead



## Case Outline - TO220 (5 lead)

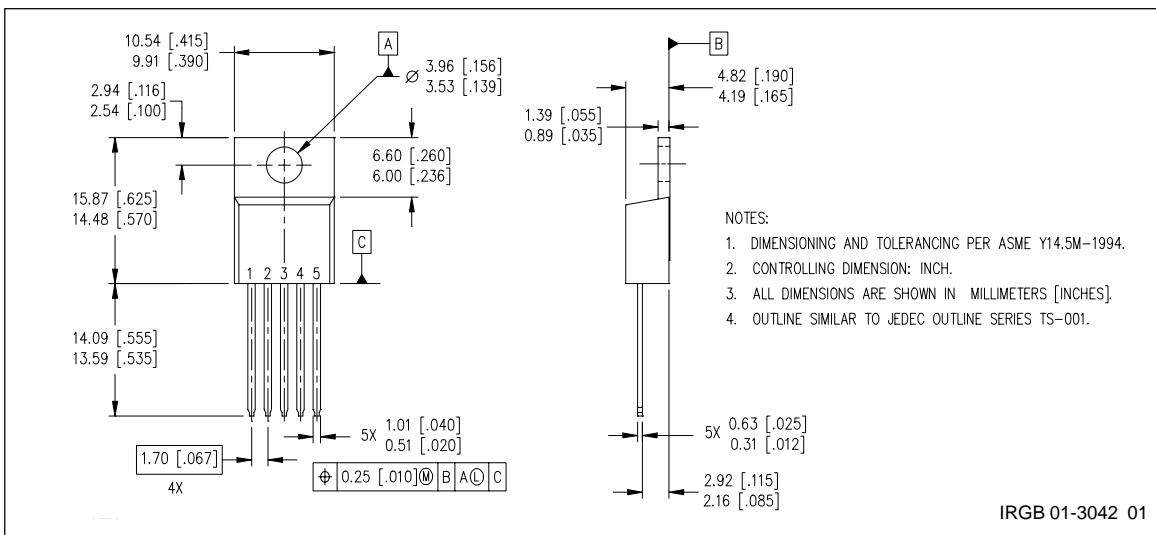

**Case Outline - D<sup>2</sup>PAK (SMD220) - 5 Lead**

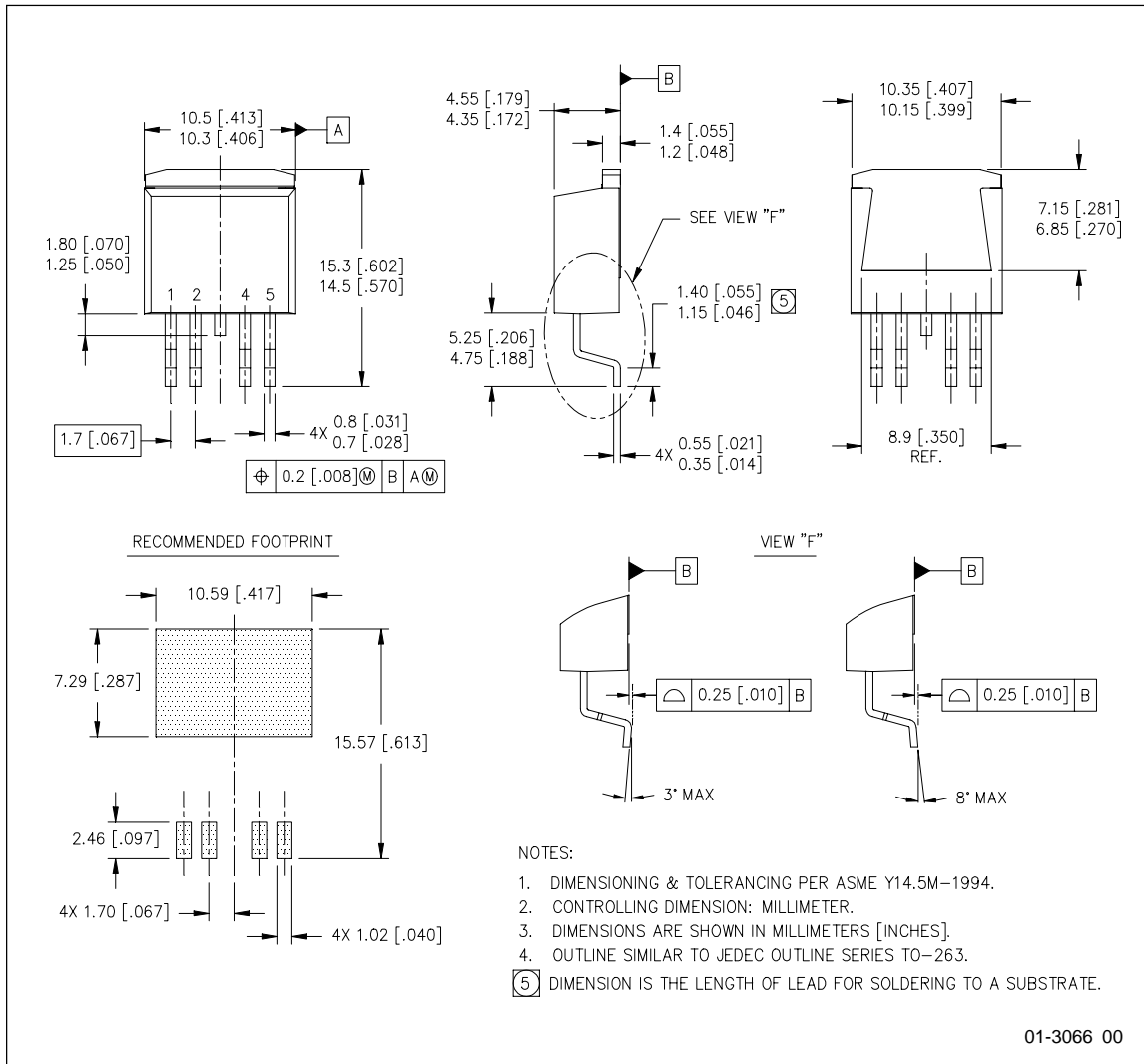

Note: For the most current drawings please refer to the IR website at:  
<http://www.irf.com/package/>