

## Solving high-voltage off-line HB-LED constant-current control-circuit issues

> Giovanni Carraro, International Rectifier

HB-LED (high-brightness light-emitting diode) use is on the rise in a growing list of applications. Driving their acceptance is an impressive list of attributes attractive to OEMs and end users alike. HB-LED's combination of high efficiency, small size, and safe low-voltage operation open opportunities for more flexible designs than traditional lighting devices. The lamps exhibit excellent cold weather performance, superior color gamut and brightness, and excellent operating life. They are also free of mercury—a growing advantage as environmental concerns push the lighting industry toward cleaner technologies.

However, with LED per-package wattages and operating currents having reached 5 W and 1.5 A, respectively, the devices' large manufacturing tolerances (Table 1) reveal that traditional control methods, such as resistive current limiting, are neither sufficiently accurate nor efficient. New circuits address the need for accurate and efficient current control

and, in some cases, economically provide useful features that simplify the application-level design.

Luxeon III	VF (V) @ 25°C			VF variation	VF Tempco (mV/°C)
	Min	Typ	Max		
White, Green, Blue	3,03	3,7	4,47	19,50%	-2
	@0.7A	@0.7A	@0.7A		
Red, Amber	2,31	2,95	3,51	20,30%	-2
	@1.4A	@1.4A	@1.4A		

Table1: Example of LED forward voltage variations

### String theory

HB-LED's brightness and color are both functions of forward current. To ensure that each HB-LED in a string produces the same light output, connect them in series. This arrangement, however, requires a current-control circuit with a large compliance voltage. Parallel connections yield poor results owing to the steepness of the HB-LED's IV curve,

**Light-Based Technologies**  
Simplify your designs with intelligent, cost-effective analog LED control and driver technologies.

**Intellectual Property**  
Unique portfolio of technologies, product designs and application techniques for the lighting and information technology industries.

**LBT High-Efficiency LED Driver**

- Current draw minimized to a single element on the load + supply
- Practically zero current draw unless load is applied
- Minimal to no heat dissipation
- No series-parallel arrangements required (12VAC can run more than 30 white LEDs at 20 mA in Series only)

\* Applications include LED replacement bulbs, SSL products, signage, matrix displays, and more.

**LB3CSA1 LED Control ASIC**

- Analog infinite resolve technology in three phase output format
- Built-in color, cycling, overlap, speed and brightness control
- Open-ended interfacing to all input sources and output loads
- Suitable for hundreds of design applications

\* Applications include RGB and white LED control, sensory and indication lighting, IT, and more.

Toll Free: (800) 875-0170 (North America)  
Global: (604) 939-4957  
Email: [info@lightbasedtechnologies.com](mailto:info@lightbasedtechnologies.com)  
[www.lightbasedtechnologies.com](http://www.lightbasedtechnologies.com)

## LED Test and Measurement



A photograph showing a large, spherical LED test chamber on a stand, connected to various electronic test equipment including a power supply, a multimeter, and a laptop displaying data graphs.

Measure all optical and electrical parameters of single LEDs, high-power LEDs and LED modules in conformity to international standards accurately and within seconds. With equipment from INSTRUMENT SYSTEMS – the world leader in LED metrology.

- Luminous intensity (candela)
- Luminous flux (lumen)
- Dominant wavelength (nm)
- Color coordinates (x, y, z)
- Spatial radiation pattern
- Thermal behavior

**INSTRUMENT SYSTEMS**  
LIGHT MEASUREMENT

phone +49 89 45 49 43-0  
[info@instrumentsystems.de](mailto:info@instrumentsystems.de)  
[www.instrumentsystems.de](http://www.instrumentsystems.de)

**WE BRING QUALITY TO LIGHT**

manufacturing tolerances that affect  $V_F$  (the forward voltage), and  $V_F$ 's drift over temperature. For example, the  $V_F$  of Lumiled's Luxeon III might vary from part to part by as much as 20% (Table 1).

Drivers for series-connected HB-LED strings must maintain constant average load current despite changes in the lamp's electrical parameters, such as temperature related drifts. A small sense resistor in series with the HB-LED provides continuous feedback of the string current.

A ground-referenced sense resistor simplifies the current-sense circuitry but requires a high-voltage driver in the buck converter. To avoid isolation transformers a design must choose either high-side sensing and a low-voltage driver or low-side sensing and a high-voltage driver. An effective method to achieve the latter is to use a high-voltage buck-converter driver with time-delayed hysteretic control (Figure 1)

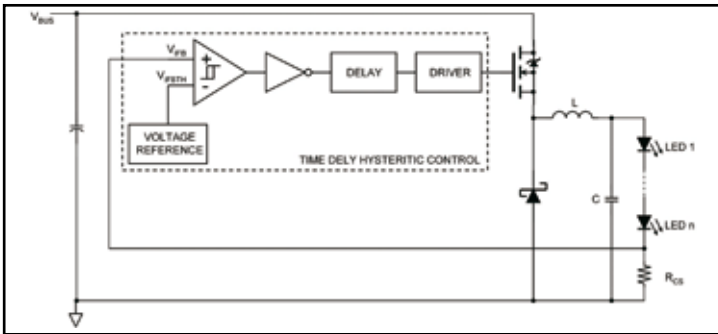

Figure 1: Time-delay hysteretic-control circuit block diagram..

## Keep current

This circuit's controller regulates the output current by comparing the feedback voltage,  $V_{FB}$ , to a nominal 0.5 V internal reference,  $V_{FBTH}$ . When  $V_{FB}$  is below  $V_{FBTH}$ , the MOSFET is on, powering the HB-LED string from the DC bus. Simultaneously, the LC resonant circuit stores energy while  $V_{FB}$  increases. When  $V_{FB}$  reaches the threshold  $V_{FBTH}$ , the MOSFET turns off after the circuit's intrinsic fixed-time delay.

The delay allows  $V_{FB}$  to increase beyond the threshold prior to the MOSFET's turn-off. With the MOSFET off, the resonant circuit releases its stored energy, powering the string. During this interval,  $V_{FB}$  linearly decreases until it reaches the fixed threshold. Though the comparator switches at the threshold crossing, the circuit's delay allows  $V_{FB}$  to decrease further before turning on the MOSFET and beginning the next cycle.

The result of the fixed time delay and the circuit's consequent continuous switching is that the controller regulates the string current to an average value  $I_{OUT(AVG)}$ , which is the numeric quotient of  $V_{FBTH}$  (nominally 0.5V) and the sense resistor,  $R_{CS}$ . This relation is valid so long as the LC tank is large enough to maintain sufficiently low ripple—less than 0.1 V.

The regulation method, which exploits the controller's delays to achieve hysteresis, allows the buck converter to operate adaptively as long as the ratio of input to output voltages stays reasonably bounded. Increasing the input-output-voltage ratio increases current ripple. The input voltage and current-limit requirements set the duty cycle. This topology provides continuous and accurate current control independent of both input and HB-LED forward voltage variations.

Figures 2 and 3 and Tables 2 and 3 reflect results this circuit attains while driving two boards of six LUXEON FLOOD 25-0032 HB-LEDs in series at 350 mA and the input voltage in the universal input range of 90 to 265 VAC. Table 2 shows good current regulation over the input-voltage range.

VAC Input (VAC)	Pin (W)	I <sub>in</sub> (mA)	I <sub>led</sub> (mA)	V <sub>led</sub> (V)	LO freq (kHz)	V <sub>BUS</sub> (V)	Efficiency $\frac{V_{led} \cdot I_{led}}{Pin}$
90	14.8	241	340	33.4	200	120	76.7%
120	15.5	207	342	33.4	180	165	73.7%
140	16.1	190	345	33.4	160	190	71.6%
180	17.4	168	348	33.4	137	245	66.8%
220	19	157	356	33.4	115	300	62.6%
265	20.8	150	362	33.4	95	360	58.1%

Table 2: Experimental results with 12 HB-LEDs (two LUXEON flood 25-0032 boards) @ 350 mA. Figures 2 and 3 indicate slightly worse ripple for higher input voltages as theory predicts, owing to the correspondingly small duty cycle. This suggests better performance in low mains-voltage regions such as North America and Japan. However, even under the worst-case condition, the controller maintains tight current regulation over the AC input range of 90 to 265 VAC. Additional measurements using one board of six HB-LEDs (Table 3) shows  $\pm 1.3\%$  regulation varying the load voltage from 33.4V to 16.4V.

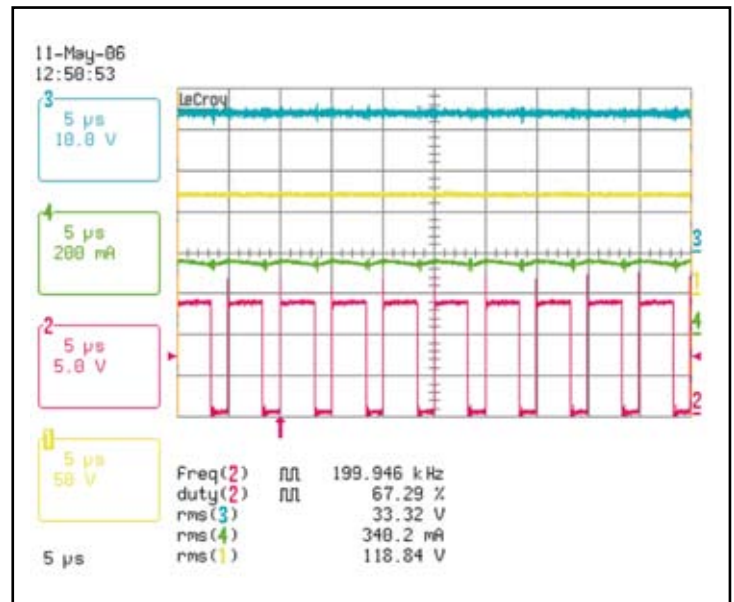

Figure 2: Oscilloscope Images: 12HB-LEDs @ 350mA 90VAC input: Yellow: (CH1) DC-Bus voltage; Red: (CH2) LO pin voltage; Blue: (CH3) HB-LEDs Voltage; Green: (CH4); HB-LEDs Current

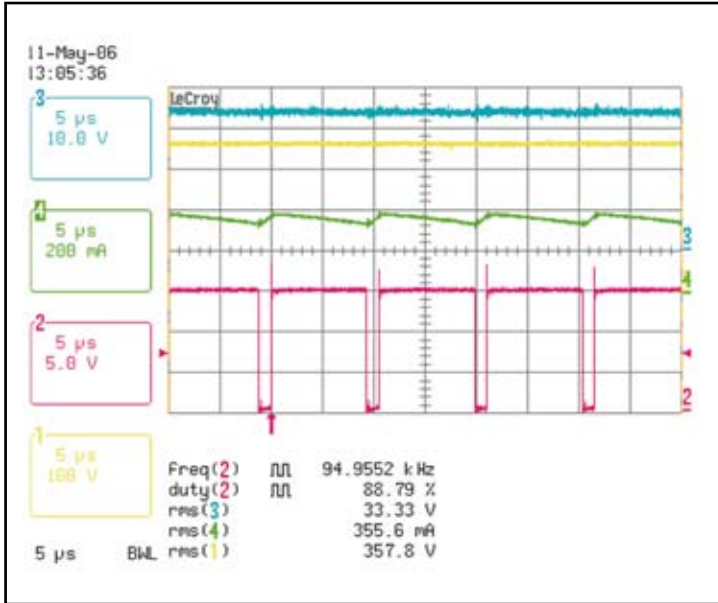

Figure 3: Oscilloscope Images: 12HB-LEDs @ 350mA 265VAC input: Yellow: (CH1) DC-Bus voltage; Red: (CH2) LO pin voltage; Blue: (CH3) HB-LEDs Voltage; Green: (CH4) HB-LEDs Current

The six-HB-LED system was less efficient than the 12-device configuration because this topology's efficiency is an inverse function of the bus-to-output voltage ratio, also illustrated in table 3. The efficiency of the six-HB-LED system can improve, however, by modifying the resonant circuit.

VAC Input (VAC)	Pin (W)	I <sub>in</sub> (mA)	I <sub>led</sub> (mA)	V <sub>led</sub> (V)	LO freq (kHz)	V <sub>BUS</sub> (V)	Efficiency (V <sub>led</sub> /I <sub>led</sub> Pin)
90	14.8	241	340	33.4	200	120	76.7%
120	15.5	207	342	33.4	180	165	73.7%
140	16.1	190	345	33.4	160	190	71.6%
180	17.4	168	348	33.4	137	245	66.8%
220	19	157	356	33.4	115	300	62.6%
265	20.8	150	362	33.4	95	360	58.1%

Table 3: Experimental results with six HB-LEDs (one LUXEON flood 25-0032 board) @ 350 mA

## In synch

Modifying the converter to a synchronous-buck topology improves the circuit's efficiency, particularly for higher load currents and input voltages, with a minimal increase in circuit complexity and cost (Figure 4). Because the bus-to-output voltage ratio sets the buck converter's duty-cycle, the low-side device conducts for most of the switching period in high ratio systems. The MOSFET's I<sup>2</sup>RDS(on) conduction losses are usually small compared to the diode's VI dissipation term. However, to properly compare the two topologies, also consider the losses due to the diode's reverse-recovery time compared to that of the MOSFET's body diode.

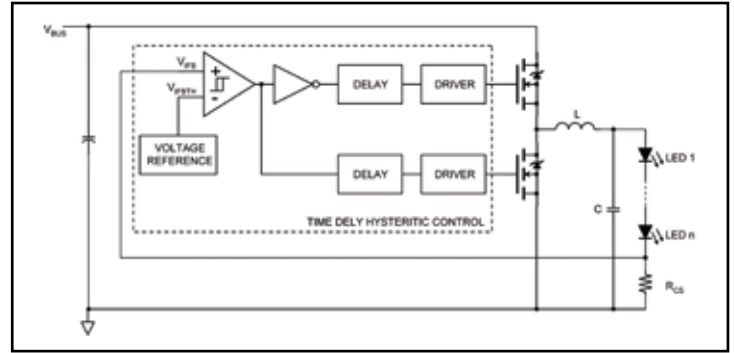

Figure 4: Time Delay Hysteretic Control block diagram circuit implemented in a synchronous buck converter configuration.

When the high-side MOSFET turns on, the common node, VS, rapidly slews from ground to V<sub>BUS</sub> and the low-side MOSFET or the diode conducts current from VS to ground during the reverse-recovery time. This results in power loss, heating, and component stress to the low-side switching device. The diode's reverse-recovery time is typically much shorter in comparison to the MOSFET's body diode. At low frequencies and load currents, the MOSFET body diode's long recovery time may not be an issue but at high frequencies and currents be sure to compare each topology's total losses through the low-side device to optimize your design.

To mitigate the MOSFET body diode's reverse recovery losses, connect a Schottky diode in parallel with the MOSFET. Due to the difference in the two devices' forward voltages, the inductor will draw its current through the Schottky during the switching deadtime. When the high-side FET turns on, the Schottky's faster reverse-recovery time will dominate the circuit behavior because the body diode will not have been operating in its forward conduction mode. During the low-side conduction interval, however, the MOSFET's low RDS(on) will ensure low conduction losses.

## References

1. *Limiteds Luxeon III DS45*
2. *K.H. Billings, Switch mode power supply handbook, McGraw Hill, 1989*
3. *O. Ronat, P. Green; International Rectifier, El Segundo, CA; Selecting the Right Driver Topology for an LED System; Intertech LED 2005 Proceedings; Oct.2005*
4. *O. Ronat, P. Green, S.Ragona; International Rectifier, El Segundo, CA; Accurate current control to drive high power LED string; APEC 2006 Proceedings; Mar.2006*