

**High Efficiency Space Grade DC-DC Converter is a Prime Solution for Modern Day
Digital Loads**

By

**Tiva Bussarakons
International Rectifier, HiRel Business Unit**

Table of Contents

1.0	Introduction	4
2.0	GH Series DC-DC Converters	4
2.1	Product Description	6
2.2	Key Features	7
2.3	Standard Output Models	7
3.0	Design Topology	8
3.1	Input Filter	9
3.2	Power Stage and Overload/Short Circuit Protection	11
3.3	Synchronous Output Rectification	12
3.4	Output Regulation (Feedback and Control)	12
3.5	Output Filter	12
3.6	Input Under-voltage Protection	12
4.0	Functional Features	12
4.1	Inhibit (On/Off Control)	13
4.2	Synchronization	13
4.3	Remote Sense Compensation	13
4.4	Output Voltage Adjustment	13
5.0	Assembly Design and Construction	13
6.0	Package Outline and Heat Sink (Cooling) Consideration	14
7.0	Product Qualification and Design Analysis Reports	15
8.0	Radiation Performance	15
8.1	Single Event Effects (SEE) Test Results	15
8.2	Total Ionizing Dose (TID) Test Results	17
9.0	Samples of Typical Performances and Waveforms	18
	Future Developments	22
	Conclusion	22
	Acknowledgement	22
	References	22

Tables and Figures

Table 1 – GH Converters Standard Outputs and Ratings	8
Table 2 – Summary of SEE Test Results, GH2805S (5V/10A) Model	15-16
Table 3 - Summary of TID Test Results, GH2805S (5V/10A) Model	18
Figure 1 – A Simplified Distributed Power Architecture (DPA), Centralized Power System Diagram	5
Figure 2 – A Simplified De-centralized Power System Diagram	5

Table and Figures, continued

Figure 3 – Internal View of a GH Converter	6
Figure 4 – External View of a GH Converter	6
Figure 5 – GH Series Block Diagram	8
Figure 6 – Conducted Emission, Common Mode	9
Figure 7 – Conducted Emission, Differential Mode, Positive Line	10
Figure 8 – Conducted Emission, Differential Mode, Return Line	10
Figure 9 – Conducted Emission, Differential Mode, Positive Line with GH CE03 and MIL-STD-461C Limits	11
Figure 10 – A Simplified Cross Sectional View of a GH Hybrid Converter Assembly	14
Figure 11 – Output Fluctuation under SEE, 37MeV·cm ² /mg, Vin = 18V, S/N 005	16
Figure 12 – Output Fluctuation under SEE, 60MeV·cm ² /mg, Vin = 18V, S/N 005	16
Figure 13 – Output Fluctuation under SEE, 86.9MeV·cm ² /mg, Vin = 50V, S/N 005	17
Figure 14 – Output Fluctuation under SEE, 86.9MeV·cm ² /mg, Vin = 28V, S/N 004	17
Figure 15 – Output Ripple/Noise at 28V Input at Rated Load, GH2805S (5V/10A)	18
Figure 16 – Step Load Response, 5A to/from 10A, GH2805S	19
Figure 17 – Typical Efficiency Performance vs. Output Load and Input Voltage at +25°C, GH2803R3S (3.3V/15A Output)	19
Figure 18 – Typical Efficiency Performance vs. Output Load and Input Voltage at -55°C, GH2803R3S (3.3V/15A Output)	20
Figure 19 – Typical Efficiency Performance vs. Output Load and Input Voltage at +85°C, GH2803R3S (3.3V/15A Output)	20
Figure 20 – Typical Efficiency Performance vs. Output Load and Input Voltage at +25°C, GH2805S (5V/10A Output)	21
Figure 21 – Typical Efficiency Performance vs. Temperature and at Nominal Input Voltage, GH2805S (5V/10A Output)	21

As new generations of space grade FPGAs, DSPs, ASICs, memory, and other digital devices enter the market to meet the growing demand for increased bandwidth and data processing speed of the data processors and signal processors on-board a spacecraft, these new digital devices place unprecedented constraints on power supplies. The new digital devices require lower supply voltages and higher operating currents for a given power demand. For the large data and signal processor designs where the needs for power and/or current become a critical factor (s), the distributed power architecture (DPA) is often the power system of choice to ensure the optimum system performance. However, for power system designs where efficiency is the primary consideration, a de-centralized system may be the only viable solution. This paper presents the key design features and performances of a new DC-DC converter where synchronous rectification is incorporated to maximize its efficiency performance addressing the needs for a highly efficient power conversion for spacecraft designs expected to operate reliably in orbits for 15 years or more.

1.0 Introduction:

New generations of the digital devices require low supply voltage. For large or multiple data/signal processors this means the required operating current can be quite high in the order of 10A or more. Traditionally, there are at least two basic design approaches being deployed for most of the power design solutions. One popular solution depicted in Figure 1 is known as distributed power architecture (DPA) or centralized system. A basic DPA system typically uses one isolated DC-DC converter operating directly off a spacecraft power bus and two or more POLs as required. The isolated converter provides an intermediate regulated or unregulated voltage that powers the down-stream non-isolated point of load (POL) voltage regulators, which provide regulated supply voltages to the digital loads. One POL is typically required for each unique output voltage. Two or more output voltages are commonly required. Each voltage may range from 1.0 to 3.3V though the trend is moving toward sub 1V. The key benefits of this approach are enhanced dynamic performance and optimized heat distribution.

The other viable design solution depicted in Figure 2 is a de-centralized power system where several isolated DC-DC converters operating directly off a space craft power bus, are used to provide the regulated supply voltages, 1V, 1.5V, 2.5V, 3.3V, 5V, etc., as required by the digital loads. This design approach offers the maximum possible efficiency performance as it is a single stage power conversion design as opposed to a two-stage power conversion in the case of the DPA solution.

For these two basic power system designs or any other system design approaches, redundancy and other system design considerations will add complexity and may require additional DC-DC converters and POLs to satisfy the system design requirements.

IR's product offerings support both and similar system design approaches. In fact, IR offers product solutions suitable for most power system designs. The block diagrams list the family names of IR's building block DC-DC converters (i.e., LS, M3G, Zx, and GH) designed for modern day digital devices targeted for a wide range of radiation environments including designs for extended mission life of 15 years or more.

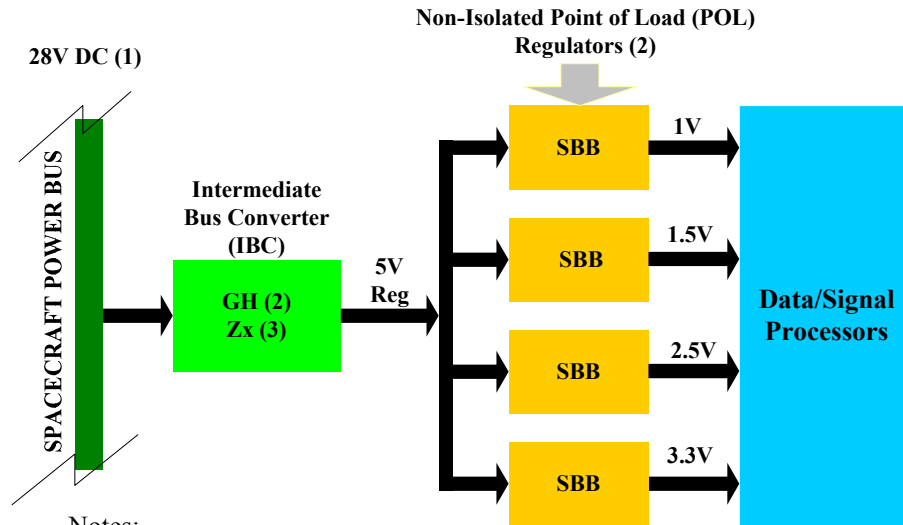

Notes:

1. Contact the factory for availability of other power bus designs.
2. Newly released standard-off-the-shelf space qualified DC-DC converter (GH) and point of load voltage regulator (SBB)
3. Zx series is for higher power (>50W) applications

Figure 1 – A simplified Distributed Power Architecture (DPA), Centralized Power System Diagram

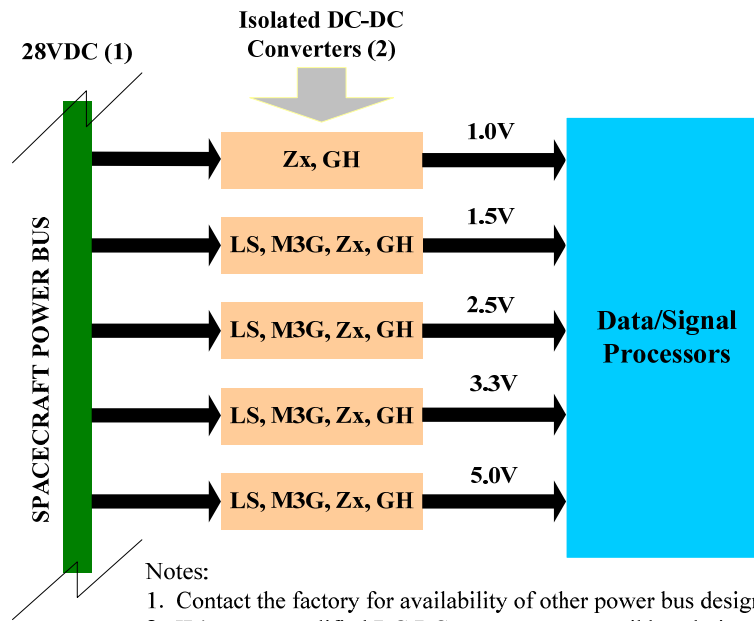

Notes:

1. Contact the factory for availability of other power bus designs
2. IR's space qualified DC-DC converters as possible solutions

Figure 2 – A simplified De-centralized Power System Diagram

Both basic design approaches have their respective merits and drawbacks. Detailed analysis and a trade-off study should be performed to insure that specific design and program objectives are met. System design criteria generally includes but not limited to, the following factors.

- System efficiency

- Dynamic performance due to parasitic impedances
- Size and weight
- Heat distribution
- Mechanical layout design
- System redundancy requirements
- Availability of the power conversion elements
- Costs

2.0 GH Series DC-DC Converters

Photos of a GH series DC-DC converter without a cover and with a cover are shown in Figures 3 and 4, respectively.

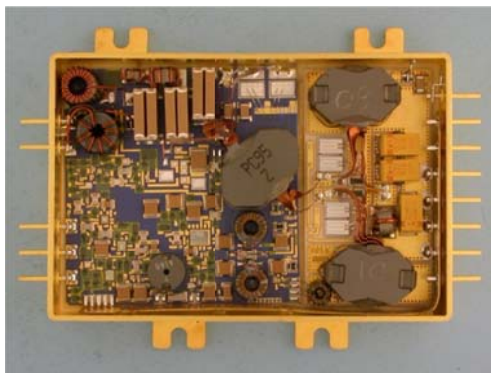

Figure 3- Internal View of a GH Converter Figure 4 – External View of a GH Converter

2.1 Product Description

The GH series DC-DC converters are a family of radiation hardened low voltage single output DC-DC converters. Its main features are high efficiency performance, small size and low mass. It is designed to operate continuously up to 20A of output current or up to a maximum of 50W of output power without power derating, over the wide operating temperature range, and under the radiation environment with a total dose radiation hardness of 100 Krads(Si) minimum and heavy ions of up to 82MeV·cm²/mg. The components stress is de-rated per the requirements of MIL-STD-1547B, MIL-STD-975M and NASA EEE-INST-002.

The GH series DC-DC converters are hermetically sealed, thick film based microelectronic hybrids. It uses the assembly design and manufacturing processes with which IR has successfully served the world's space community for almost 20 years. IR's GH series is a space qualified, standard off-the-shelf DC-DC converter. It is intended for use as building block DC-DC converter for system designs requiring high efficiency performance. The converters are class K screened per MIL-PRF-38534.

The product design drivers are efficiency, compact form factor, ease of system integration, and space flight worthiness. It offers excellent efficiency and performance capable of meeting the

power demand of today's digital loads. It is an ideal converter as a power source to multiple point-of-load regulators or as an isolated converter providing individual supply voltages directly to the digital loads from a spacecraft power bus.

2.2 Key Features

A GH series DC-DC converter is self-contained and ready for system integration for most typical applications. All internal components have been carefully evaluated and characterized to insure a reliable operation under the intended radiation environments. Design analyses including electrical stress, thermal, failure modes and effects (FMEA), reliability (MTBF), and worst case analysis (WCA) including end-of-life (EOL) performance, are standards and available upon request. Following are the key features of the GH DC-DC converters.

- Total dose >100K Rads (Si)
- SEE hardness rated, SEL/SEB/SET with LET >82 MeV-cm²/mg
- Operates from 18V to 40V DC supply
- Fixed output voltage: 1V, 1.5V, 1.8V, 2.5V, 3.3V, and 5V are standards
- ±3% end of life (EOL) output voltage accuracy
- End-of-life (EOL) worst case analysis (WCA)
- Output power up to 50W or 20A maximum without power de-rating
- Synchronous rectification with high efficiency to 87%
- -55 to +85°C operating case temperature
- Remote sense compensation
- Fixed 500 KHz operating frequency
- Output adjustable to ±10% of nominal output with external resistors
- Inhibit functional pin for remote on/off control
- Under voltage lockout (UVLO)/input under-voltage protection
- Overload and short circuit protection
- Low noise with integrated input and multi-stage output filters
- Soft start
- Synchronization, input and output
- MIL-PRF-38534 element evaluated components
- De-rated per MIL-STD-1547B, MIL-STD-975M and NASA EEE-INST-002
- MTBF > 5.8 million hours for Space Flight environment
- Size: 3.5”L x 2.5”W x 0.475”H including I/O pins and mounting tabs
- Light weight: 110 grams maximum
- Custom versions are available

2.3 Standard Output Models

Standard output models, outputs rating, part numbers, and Defense Logistics Agency (DLA) qualified SMD part numbers are shown in Table 1. The 3.3V and 5V output models are DLA class K qualified SMD devices. Consult factory for SMD qualification status of other output models.

Part Number	Output Voltage (V)	Output Current (A)	Output Power (W)	Typical Efficiency (%)	DLA Qualified SMD Part Number
GH2801S	1.0	20.0	20	73	TBD
GH2801R5S	1.5	20.0	30	75	TBD
GH2801R8S	1.8	20.0	36	78	TBD
GH2802R5S	2.5	20.0	50	83	TBD
GH2803R3S	3.3	15.2	50	85	5962-10217
GH2805S	5.0	10.0	50	87	5962-10219

Table 1 – GH Converters Standard Outputs and Ratings

3.0 Design Topology

Block diagram of a GH DC-DC converter is shown in Figure 5.

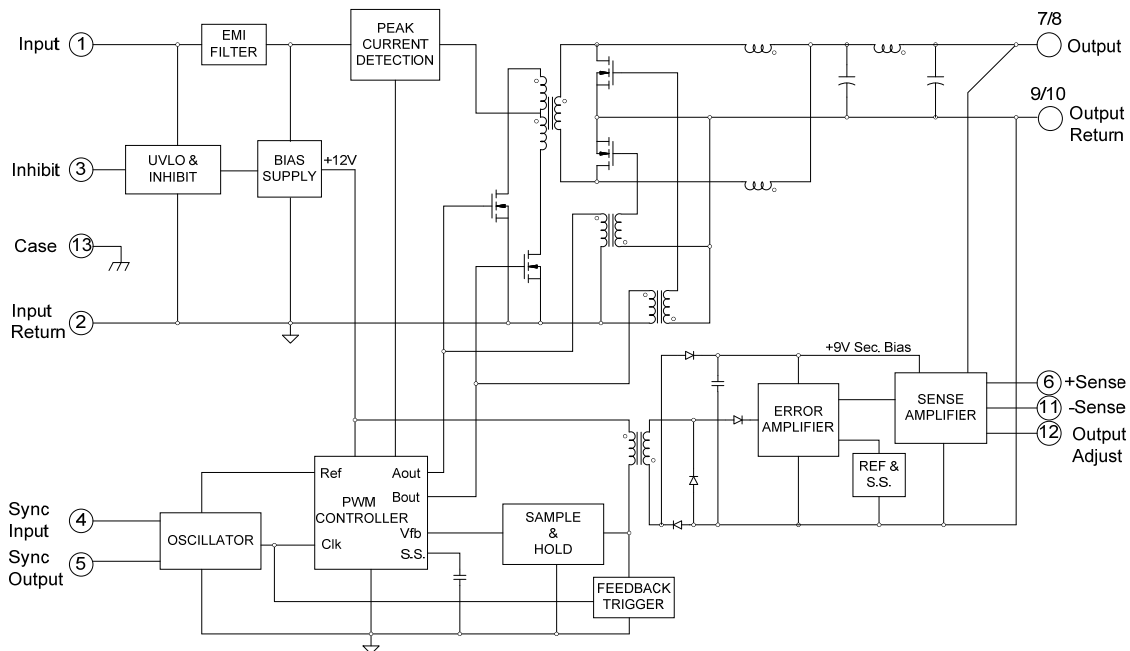

Figure 5 - GH Series Block Diagram

The GH-Series converter topology uses peak current mode control and features a push-pull front-end with a current-doubler output stage. The converter utilizes synchronous rectification to maximize efficiency, and features a proprietary magnetic feedback circuit that also provides power to electronics in the secondary. An external oscillator circuit is used in conjunction with a UC1825 PWM controller to improve the switching frequency stability, and to provide a synchronization input and output for multiple converters operation as desired. Incorporation of

an under-voltage lockout (UVLO) circuit guarantees that a low input bus voltage cannot induce abnormal operation of the controller circuitry and a loss of regulation at the converter's output. The design also features an internal input EMC filter to minimize emissions conducted back to the input bus.

The converter's output is galvanically isolated from the input. Both input and output are isolated from the case. Transformers provide isolation for the input and output circuits while the assembly substrates provide isolation for the input and output circuits to the case. The design of the GH series is drawn from IR's design library with known EEE components and circuit performance with excellent reliability track records. Many of the same circuit designs are operating in orbits today.

3.1 Input Filter

The input filter incorporates a multi-stage common mode and differential mode design to attenuate the conducted emission required by most spacecraft power buses and to insure the converter stability over the intended dynamic line and load conditions. The typical conducted emission performances with respect to the CE03 limits of MIL-STD-461C are shown in Figures 6- 8. Figure 9 shows the typical CE03 performance with the GH's input EMC performance limit and the CE03 limits of MIL-STD-461C.

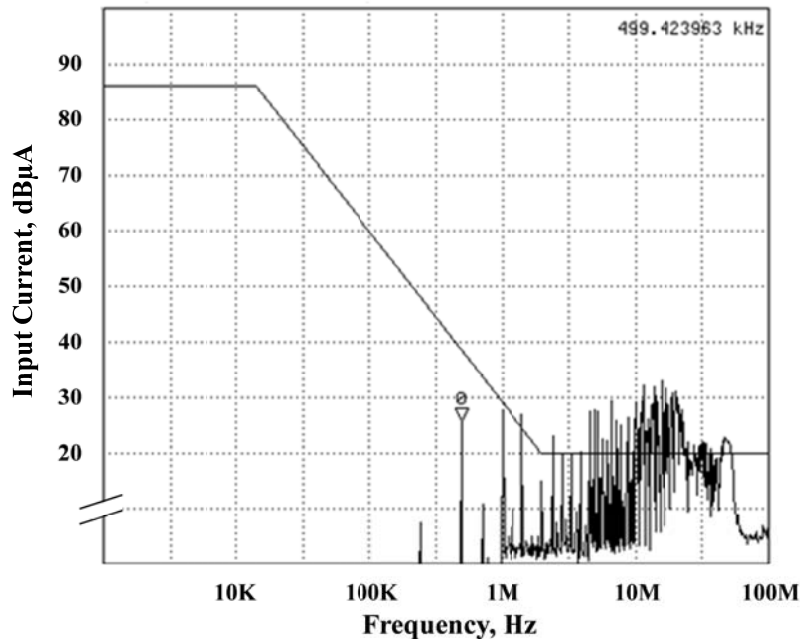

Figure 6 - Conducted Emission, Common Mode

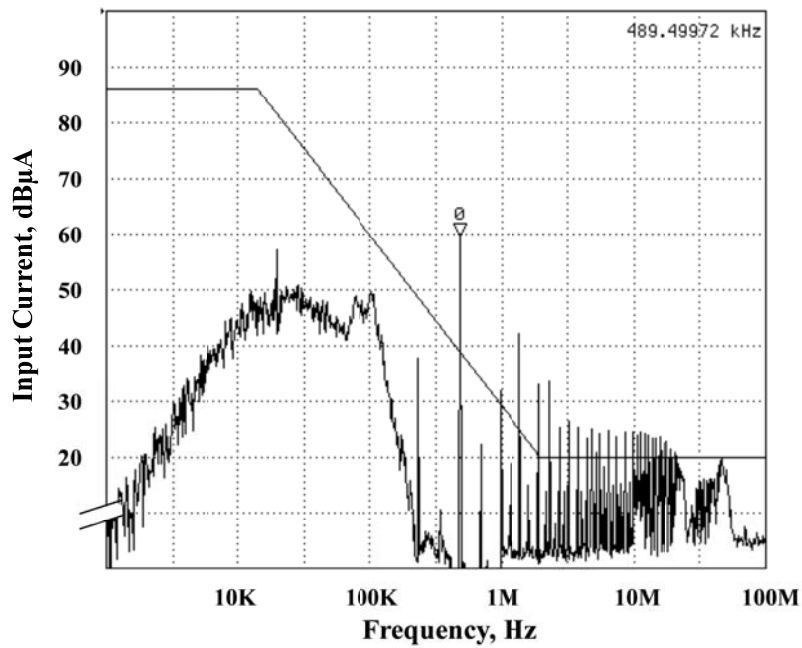

Figure 7 - Conducted Emissions, Differential, Positive Line

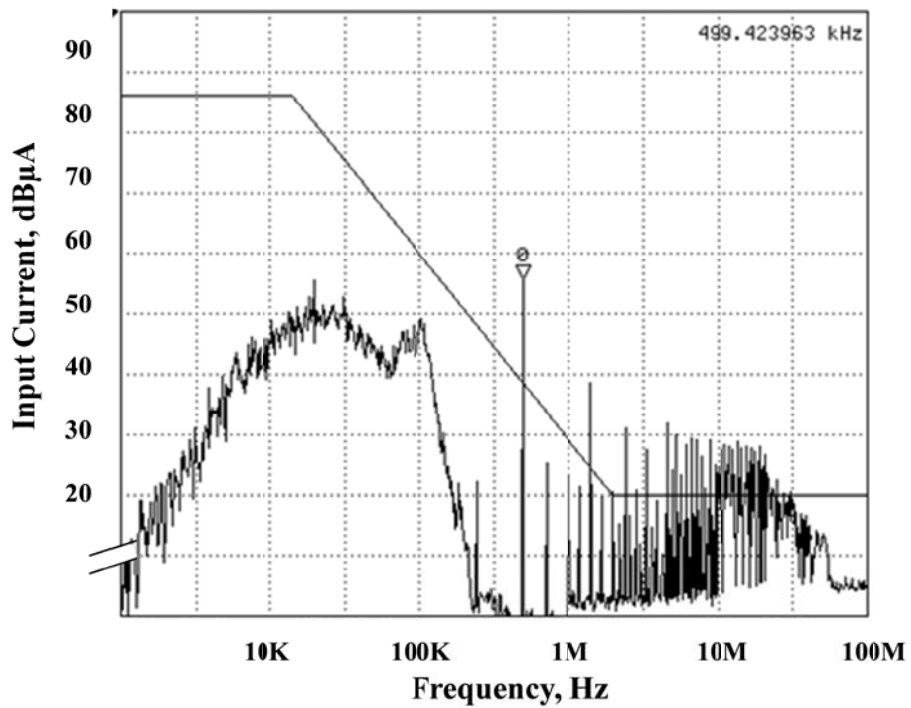

Figure 8 - Conducted Emissions, Differential, Return Line

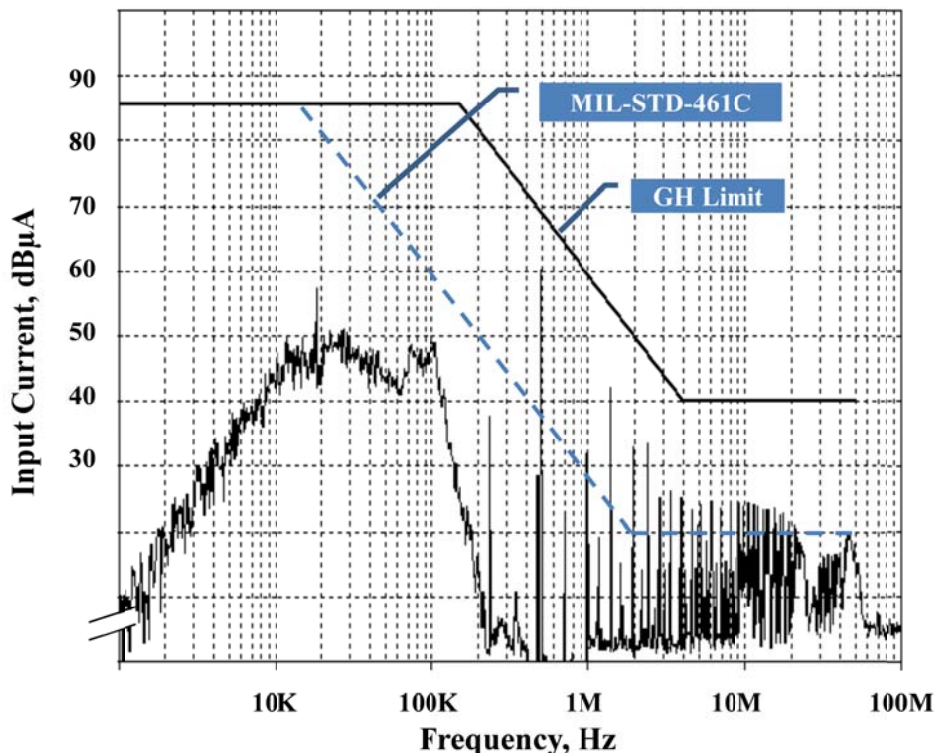

Figure 9 — Conducted Emission, Differential Mode, Positive Line with GH CE03 and MIL-STD-461C Limits

The CE03 maximum limits for the GH converters are defined as follows:

Frequency Range, Hz	GH CE03 Input Current Limits, dBμA
<150KHz	86 dB max.
150KHz - 4MHz	86 dB decreasing linearly to 40 dB
4MHz to 50MHz	40 dB max.

3.2 Power Stage and Overload/Short Circuit Protection

The design uses IR's R6 generation advanced rad-hard power MOSFETs IRHC63230 with 200V VDS rating for the push-pull power stage switches. The switches are driven directly by the outputs of the UC1825 PWM controller operating at a fixed frequency of approximately 500 kHz. Primary-side current sensing with a current transformer is used to monitor peak current which is used as a PWM ramp. The same current sensing scheme also serves to protect the converter in the event of an output overload or short circuit condition. The protection scheme is of a constant current type. The output current will remain nearly constant during an overload or short circuit condition when the output current reaches a preset threshold level (approximately

125% of rated current). The converter will return to normal operation and resumes output regulation upon removal of an overload/short circuit condition.

3.3 Synchronous Output Rectification

Synchronous rectification is deployed to maximize conversion efficiency performance. IR's R5 generation rad-hard MOSFETs IRHC57034 are used for 3.3V and 5V models, IRHC57Z30 for lower output voltage models. The synchronous rectifiers receive a main gating signal from the primary side PWM through a gate drive transformer and the bias power from a secondary side housekeeping voltage derived from the main power stage transformer.

3.4 Output Regulation (Feedback and Control)

Refer to Figure 3. The output voltage is sensed through a resistive divider network, processed by Sense Amplifier and compared to a fixed voltage reference at the input to Error Amplifier (E/A). The E/A provides a high DC gain to keep the DC operating point fixed and corrects for changes in the output voltage due to line voltage and load current variations by incorporation of a combination of resistors and capacitors in its feedback path. These resistor/capacitor combinations give the required bandwidth with proper gain and phase margins.

The E/A output signal (DC level with AC modulated) is then chopped and transferred through a feedback transformer from the secondary to the primary side. This secondary-to-primary magnetic feedback (with sample-hold) allows for greater tolerance to higher total ionizing dose (TID) radiation levels (as compared to the opto-coupler feedback method which has significant current transfer ratio variation over radiation). The primary feedback signal is then reconfigured as an AC modulated DC error signal. This signal is then applied to the primary-side PWM and compared to a peak current ramp.

3.5 Output Filter

The output filter circuit is a two-stage L-C filter that minimizes both the fundamental and high frequency ripple and noise. The two-stage filter also meets the needs for low output impedance ensuring acceptable overshoot and undershoot excursions of the output voltage when the load is transitioned to and from a light to a heavy load. A typical step load output response and the output ripple/noise waveforms are included in the typical performance section of this paper.

3.6 Input Under-Voltage Protection (UVP)

The GH series DC-DC converters are protected against an input under-voltage condition when the input power source drops below the low line limit of approximately 15.5V. It is a non-latching class with an automatic restart when the input voltage rises to approximately 17V and returns to the normal operating range. The input UVP circuit senses the input bus supply voltage and compares it to the input UVP reference. If the input voltage is below the preset threshold (approximately 17V), the converter will not operate, and there will not be any voltage at the output. When the input rises above the preset threshold, the converter will provide a regulated output. The turn-on and turn-off threshold levels vary slightly with temperature. The UVP includes an on-off hysteresis preventing the GH from turning on and turning off in the event the input power source does not rise monotonously.

4.0 Functional Features

The GH series DC-DC converters include several key functional features that benefit the typical design applications. They are output on/off control, frequency synchronization of multiple converters, remote output sensing compensation, and precision output voltage setting.

4.1 Inhibit (On/Off Control)

The GH DC-DC converters can be commanded on and off via the Inhibit pin (Pin 3). The converter will turn off when the Inhibit pin is pulled low with the signal of 0.8V or lower with respect to the Input Return pin (Pin 2) and the normal input power (18 -40V) is present at the input port (pin 1 and pin 2). The converter will turn on when the Inhibit pin is left open or with a signal of greater than 2V applied to this pin. The typical turn-on threshold is approximately 2V with respect to Input Return. The Inhibit pin can also be used to control multiple GH converter modules for output sequencing. Please refer to the GH series data sheet to size the power requirements of the control signal.

4.2 Synchronization

Multiple GH converter modules can be synchronized to a common operating frequency with an external signal source with the frequency range of 500±50 KHz. Specific requirements of the synchronization input signal can be found in the GH series data sheet. Each GH converter can also source and accept a signal from another GH converter in a daisy chain fashion, i.e., Sync Out A to Sync In B, Sync Out B to Sync In C, and so on. This way, each synchronization output (Sync Out) is driving only one synchronization input (Sync In), and the oscillators of the converters are slightly out of phase with one another, which reduces the combined input ripple/noise.

4.3 Remote Sense Compensation

For proper operation, the +Sense (pin 6) and –Sense (pin 11) must be connected to the Output pins (pins 7 and 8) and the Output Return pins (pins 9 and 10), respectively. The GH converter is capable of compensating for a voltage drop in the output lines for operation where the load is some distance away from the converter. This can be accomplished by connecting the +Sense (pins 6) to the high potential point at the load, and connecting the –Sense (pin 11) to the lower potential point at the load. The maximum compensated voltage can be as high as 10% of a nominal output voltage of the converter if the output voltage adjustment feature is not used.

4.4 Output Voltage Adjustment

The GH converter also includes an output voltage adjustment capability for a precise output voltage setting. Output voltage of each converter is pre-trimmed to a standard voltage at the factory. The standard voltages are 1.0V, 1.5V, 1.8V, 2.5V, 3.3V, and 5V. However, if the output voltage needs to be slightly lower or higher than a given standard, the output of the GH converter can be set to a desired voltage with the addition of an external resistor. The combined voltage of the increased output voltage and the voltage drop in the output lines (if the remote sense compensation feature is used) is limited to ±10% of the nominal output voltage. If the remote sense feature is not used, the maximum adjustable output voltage can be as high as 10% above the nominal output. The formula for a desired output voltage and a corresponding application note can be found in the GH data sheet.

5.0 Assembly Design and Construction

A cross sectional view of a GH converter assembly is shown in Figure 10. Similar to most of IR's DC-DC converter products, the GH series DC-DC converter is a thick film hybrid hermetically sealed assembly. The assembly design and construction offer many distinct benefits. The hybrid assembly with its inherent iso-thermal plane offers the shortest thermal paths from the components to the base for cooling, yielding the lowest possible junction thermal impedances. Along with the use of high thermal conductivity materials throughout the design, the best possible thermal performance is achieved. The assembly design ensures the minimum temperature rise on the internal components, thus enhancing the product's reliability.

The package's base and side wall are welded. Similar to IR's M3G space qualified product, the package is constructed with an AlSiC (aluminum silicon carbide) base and Alloy 48 (nickel-iron) ring frame to minimize weight and offer assembly ruggedness. The lid is Kovar. It is seam sealed to the package for the air-tight construction which promotes long term reliability. The basic cross sectional view of the GH converter assembly design is shown in Figure 3.

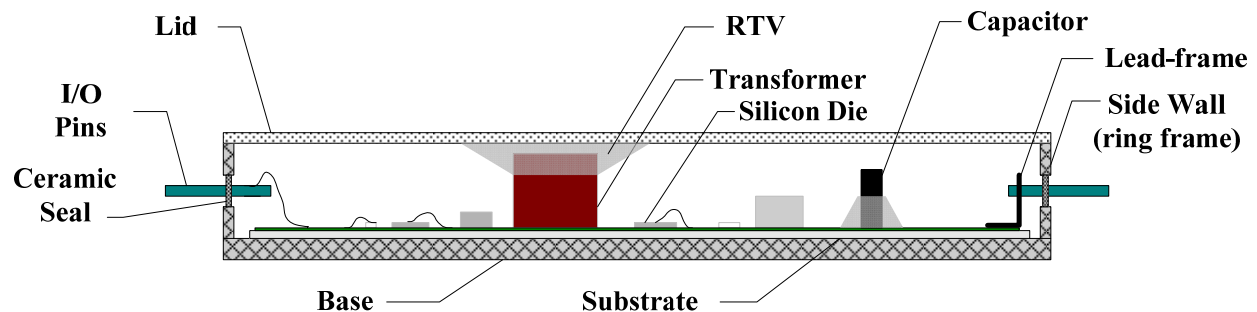

Figure 10 – A Simplified Cross Sectional View of a GH Hybrid Converter Assembly

Assembly begins with attachment of electrical components by way of solder reflow or adhesive epoxy to bare alumina substrates with screen printed resistors for the input and control circuitries. Direct bonded copper (DBC) substrate is used for the output electronics to accommodate the high output current design minimizing the conduction loss. Transformers and other magnetic parts are attached to substrates with thermally conductive epoxy. The assembled substrates are then epoxy attached to the base. Lead-frames and transformer/inductor leads are attached from the substrate to substrate and substrates to the I/O pins. The assembly is then inspected for acceptable workmanship and tested to insure proper functionality. High profile components are secured with a silicone-based gap filler to enhance mechanical stability for the intended shock and vibration environments. The assembly is completed with seam sealing the lid. A completed assembly is tested to insure proper functionality and is subjected to additional reliability screening as required.

6.0 Package Outline and Heatsink (Cooling) Consideration

The GH converters use the same package design as IR's heritage-rich M3G series. The overall package outline measures 3.5" L x 2.5" W x 0.475" H. The length and width dimensions include protrusion of the input/output pins and the mounting tabs. The package footprint measures 3.0" x 2.0". The mounting tabs layout design is such that it allows the multiple GH converter modules to be placed side by side where the mounting tabs of one unit can be placed in line adjacent with the other unit(s) to minimize the board space. Adequate cooling must be provided for a GH

module. A GH converter must be attached to a thermally conductive surface for cooling. A thermally conductive pad similar to a SIL-PAD is recommended to fill the voids between the base of the package and the surface to which a GH module is mounted. Contact the factory for mounting procedure which includes the recommended mounting screws, SIL-PAD material, mounting sequence, and mounting torque requirements.

7.0 Product Qualification and Design Analysis Reports

Flight hardware of the GH series DC-DC converters is now available with a standard lead time for a space qualified product from IR. The product is internally qualified to Class K in accordance with MIL-PRF-38534. Representatives of the GH converter qualification model were subjected to and successfully passed both the total ionizing dose (TID) and single event effects (SEE) radiation tests. Class K qualification reports including life test and radiation tests reports are available.

Also available are design analysis reports which include electrical stress, thermal analysis, failure mode and effects, reliability (MTBF), and worst case analysis (WCA). Please contact the factory for these reports.

8.0 Radiation Performance

Samples of GH2805S (5V output) DC-DC converter were subjected to total ionizing dose (TID) and single event effects (SEE) heavy ions tests. The test samples successfully passed the TID and SEE tests and are qualified for flight use under the intended radiation environments.

8.1 Single Event Effects (SEE) Tests Results

The GH converters successfully passed the SEE tests with the LET = 86.9 MeV·cm²/mg. However, the converters exhibited minor sensitivity to the heavy ions testing. The highest output voltage fluctuations observed are shown in the Figures 11 through 14. The highest output voltage fluctuations recorded were 160mV (3.2% of 5V) and are well within the 10% limit of nominal output voltage. Below are summary of the test results and the corresponding output fluctuation waveforms. The converters were operating at 5V/5A, 50% of the rated load with nominal input voltage of 28V DC applied. Refer to IR's document RAD-173323SEE Single Event Effects test report for detailed SEE radiation test results.

<u>S/N 005</u>				
<u>Effective LET</u> (MeV·cm²/mg)	<u>Energy - Ion</u> Species (MeV)	<u>Highest</u> <u>Output</u> Deviation (mV)	<u>Waveform</u>	<u>Remarks</u>
37.8	372 - Krypton	160 (3.2%)	Figure 11	Highest output deviation occurs at low line input (18V)
60.0	737 - Xenon	120 (2.4%)	Figure 12	Highest output deviation occurs at low line input (18V)
86.9	1961 - Gold	150 (3.0%)	Figure 13	Highest output deviation occurs at high line input (50V)

S/N 004				
<u>Effective LET</u> (MeV·cm ² /mg)	<u>Energy - Ion</u> Species (MeV)	<u>Highest Output</u> Deviation (mV)	<u>Waveform</u>	<u>Remarks</u>
86.9	1961 - Gold	160 (3.2%)	Figure 14	Highest output deviation occurs at nominal line input (28V)

Table 2 – Summary of SEE Test Results, GH2805S (5V/10A) Model

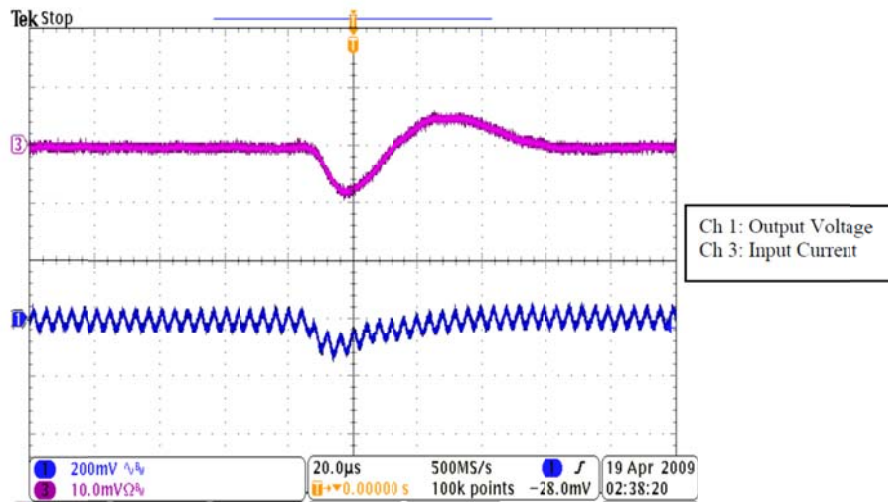

Figure 11 – Output Fluctuation under SEE, 37MeV·cm²/mg, Vin = 18V, S/N 005

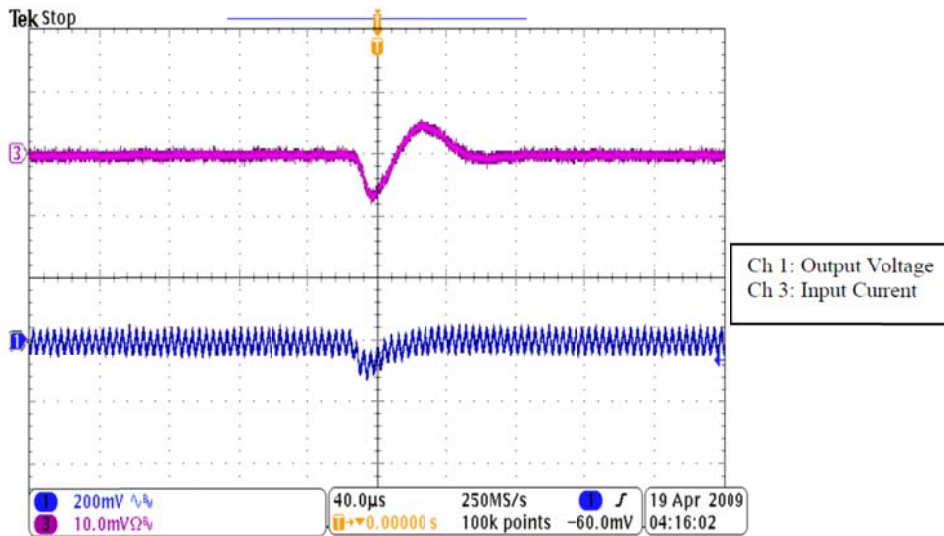

Figure 12 – Output Fluctuation under SEE, 60MeV·cm²/mg, Vin = 18V, S/N 005

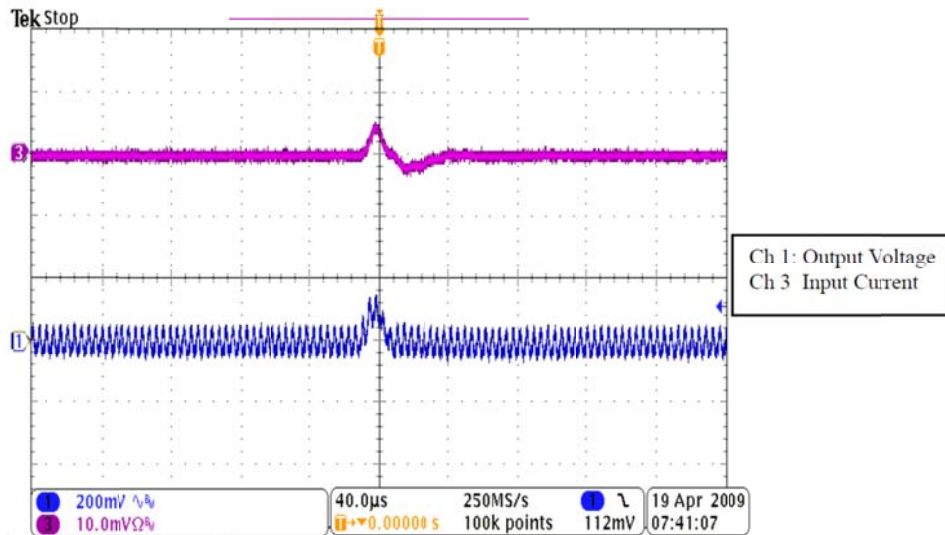

Figure 13 – Output Fluctuation under SEE, 86.9MeV·cm²/mg, Vin = 50V, S/N

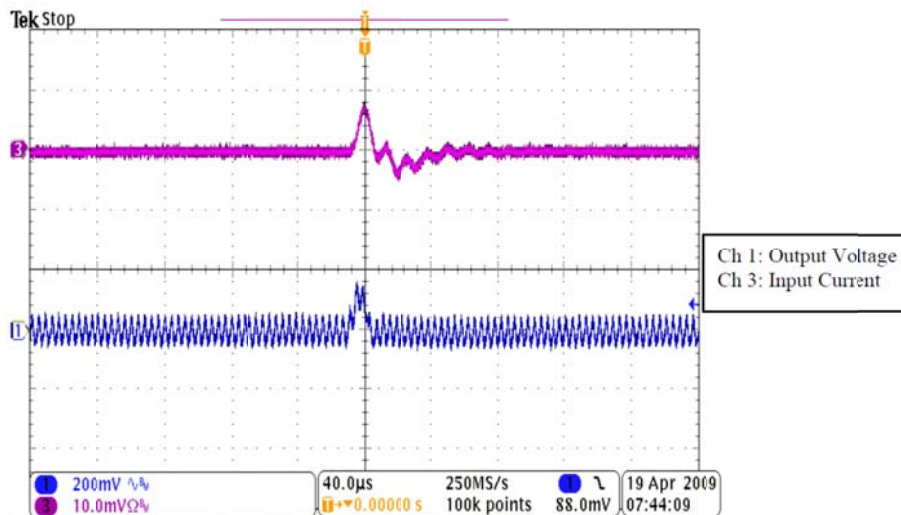

Figure 14 – Output Fluctuation under SEE, 86.9MeV·cm²/mg, Vin = 28V, S/N 004

8.2 Total Ionizing Dose Test Results

A total of four (4) GH2805S devices were subjected to total ionizing dose (TID) test in accordance with MIL-STD-883, Method 1019.5 Condition B. All four (4) devices successfully passed the TID tests after exposure to TID of 150Krad and annealing process at +100°C for 168 hours. Below is the summary of the key electrical performances of two devices that have undergone the TID exposure. Refer to IR’s document RAD-173323TID for detailed TID radiation test results.

Test Conditions:

Input: 28V DC

Output: 5V/5A (50% of rated load)
 Dose Rate: 2.5Krad/minute
 Total Ionizing Dose: 150 Krads
 Anneal: at +100°C for 168 hours per Method 1019.5

<u>Parameter</u>	<u>Pre-Radiation</u>	<u>Post-Radiation</u>	<u>Post Anneal</u>	<u>Net Change</u>	<u>% Change</u>
S/N 004					
Output Voltage (VDC)	5.002	4.962	4.995	-7mV	-0.1%
Efficiency (%)	86.724	86.571	86.622	-0.102%	-0.1%
Switching Frequency (KHz)	505.63	515.99	508.72	+3.09KHz	0.6%
S/N 005					
Output Voltage (VDC)	5.005	4.963	4.994	-11mV	-0.2%
Efficiency (%)	86.746	86.563	86.548	-0.198%	-0.2%
Switching Frequency (KHz)	505.4	516.89	509.04	+3.64KHz	0.7%
Notes:					
1. Both test samples passed all Group A electrical tests after annealing.					
2. Test results were similar to the pre-radiation for all three temperature Group A data.					

Table 3 – Summary of TID Test Results, GH2805S (5V/10A) Model

9.0 Samples of Typical Performances and Test Data

Following are samples of the typical performance of the GH series DC-DC converters.

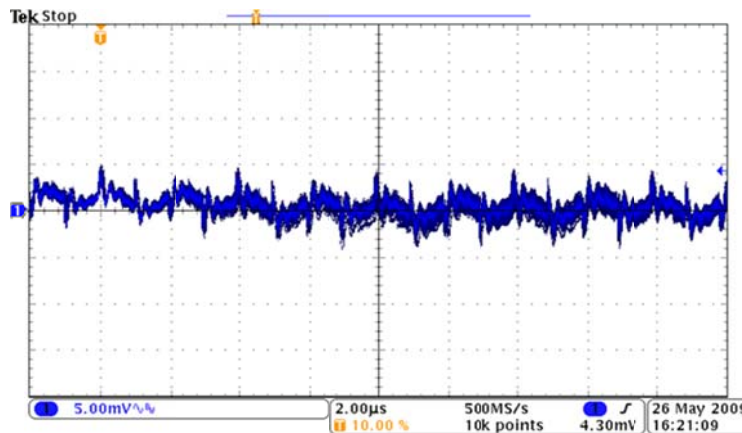

Measured Output Ripple: ~ 8mVp-p, 20MHz band width

Figure 15 – Output Ripple/Noise at 28V Input and Rated Load, GH2805S (5V/10A Output)



Measured Output Response to Step Load:

Overshoot: ~150mV, 250 µs

Undershoot: ~147mV, 250µs

Figure 16 – Typical Step Load Response, 5A to/from 10A, GH2805S (5V Output)

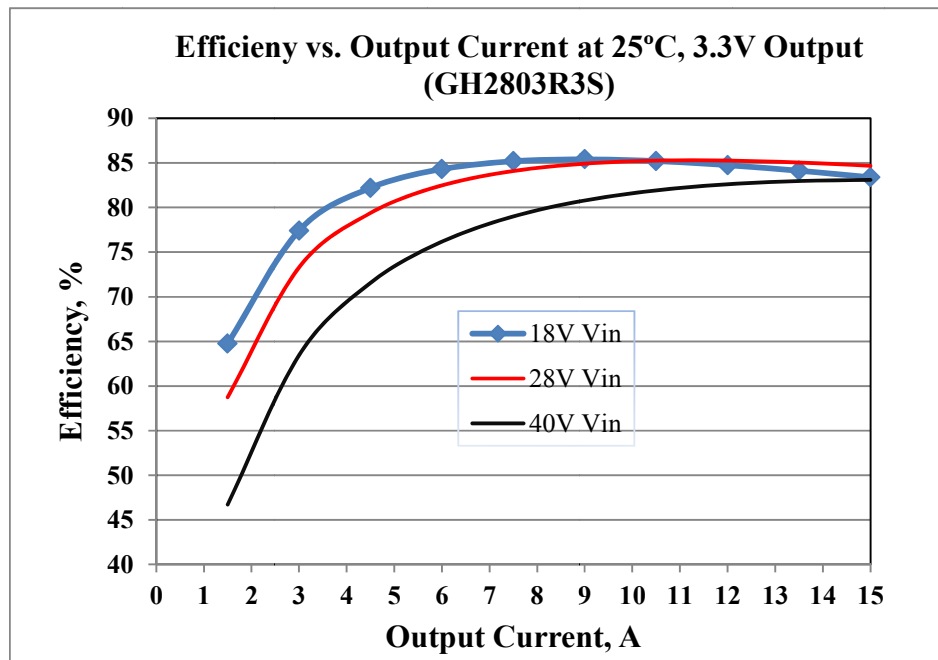

Figure 17 – Typical Efficiency Performance vs. Output Load and Input Voltage At +25°C, GH2803R3S (3.3V/15A Output)

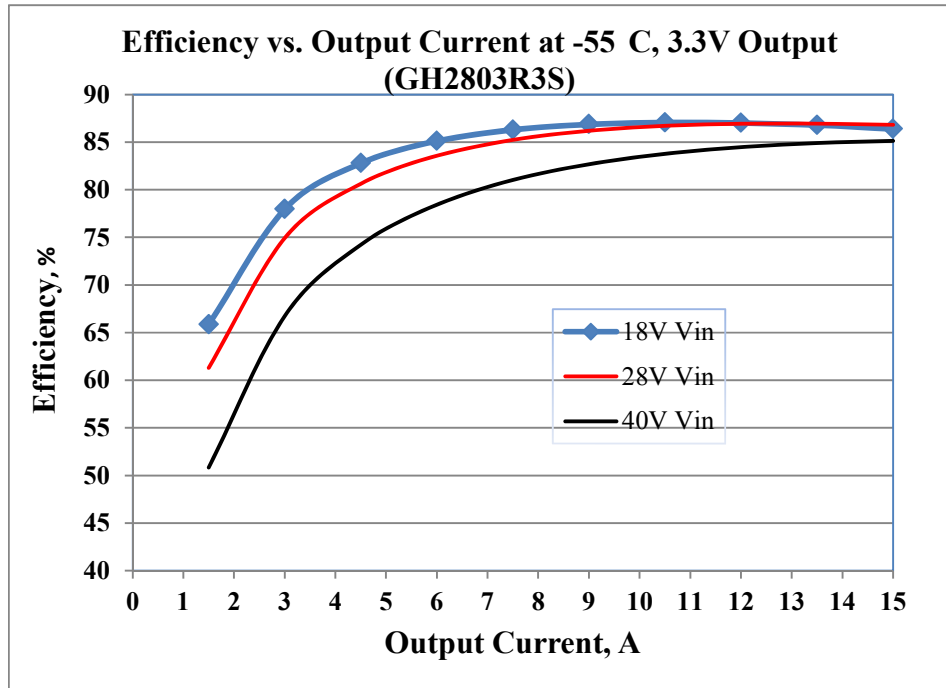

Figure 18 – Typical Efficiency Performance vs. Output Load and Input Voltage At -55°C, GH2803R3S (3.3V/15A Output)

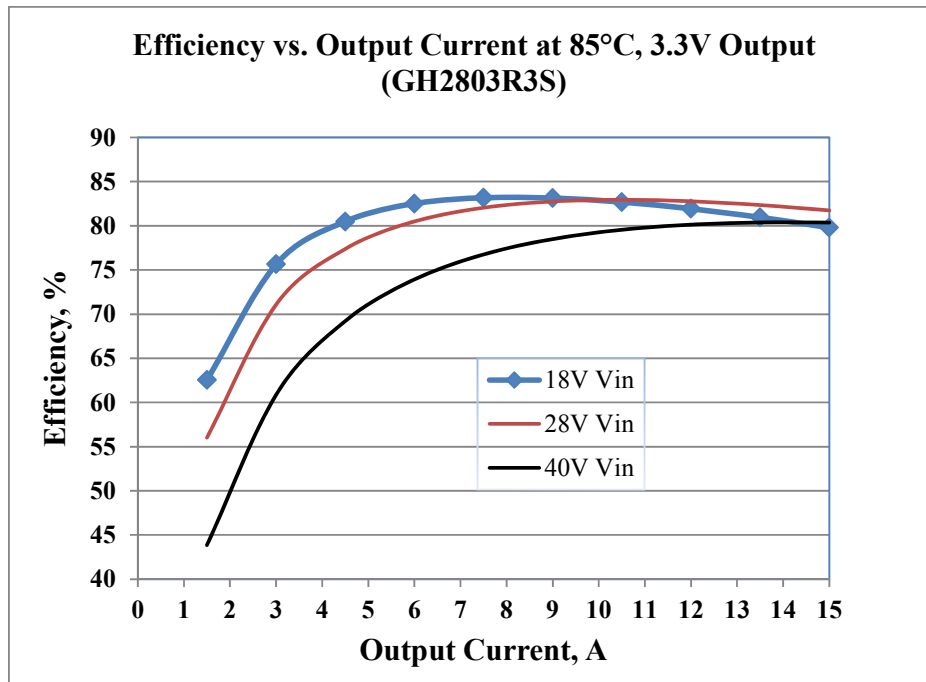

Figure 19 – Typical Efficiency Performance vs. Output Load and Input Voltage At +85°C, GH2803R3S (3.3V/15A Output)

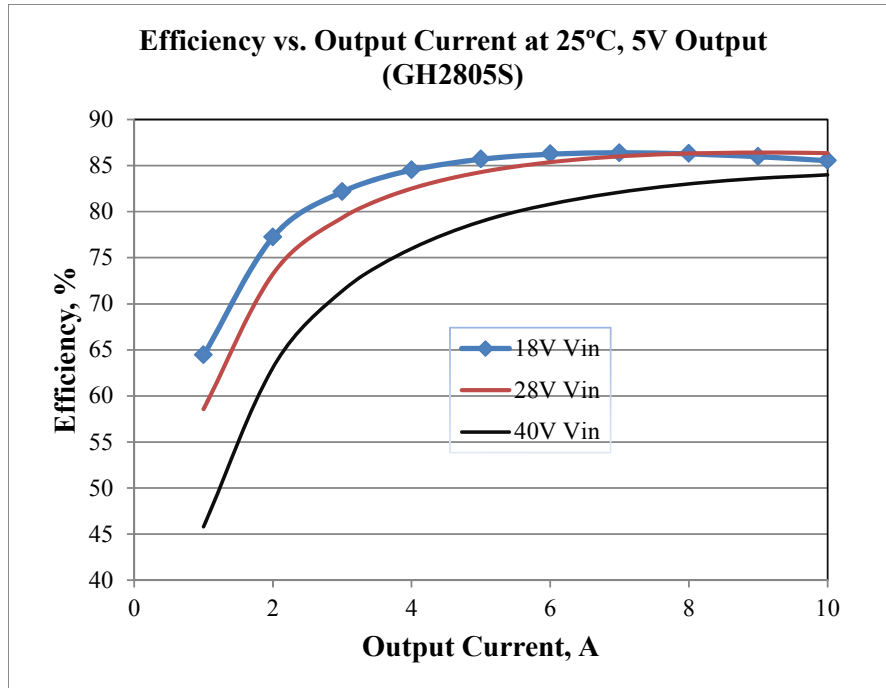

Figure 20 – Typical Efficiency Performance vs. Output Load and Input Voltage At +25°C, GH2805S (5V/10A Output)

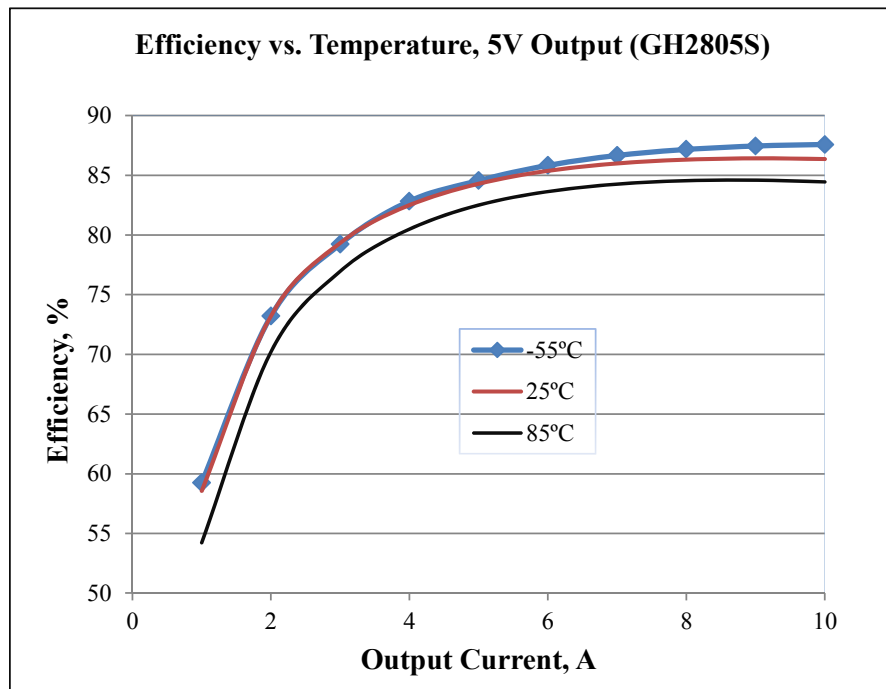

Figure 21 – Typical Efficiency Performance vs. Temperature and at Nominal Input Voltage, GH2805S (5V/10A Output)

Future Developments:

Other platforms in development in support of the market demand and design trends include the ZA series (a 100W version of the Zx design platform) IBC, single output, high efficiency isolated DC-DC converter and the SBA series POL, a 6A non-isolated point of load regulator, a lower output power version of the SBB. For low power design applications, D series, a two output 10W DC-DC converter will be available soon to meet the demand for low power design applications. Both the GH and SBA series also target the lower power DPA power system designs, whereas the ZA series is intended to support the moderate DPA power design applications. Please contact IR for the latest development status of these and other new design platforms.

Conclusion:

After years of extensive design and engineering, IR has successfully met the challenges in design and development of the first isolated hybrid DC-DC converter incorporating synchronous rectification to maximize the efficiency performance for low to moderate power design applications. Key factors in the successful development include the components selection for the challenging radiation environments, materials selection, proven design topology, conservative components de-rating, assembly design, and process development. The GH converter offers immediate benefits in reduced program costs, short lead time and ease of system integration. With its high efficiency performance and a compact footprint, the GH series DC-DC converters are ideal for the de-centralized and centralized DPA design systems solutions for the modern day digital devices.

Acknowledgement:

I would like to thank Steve Baker, Ho-Pu Wu and Bjarne Soderberg for their invaluable technical advice.

References:

1. "Military Satellites Pose Engineering Challenges in DC-DC Converter Development", Tiva Bussarakons, Defense Electronics, A Primedia Publication, May 2004.
2. "Thick Film Hybrid DC-DC Converters are Standard 'Brick' for Satellite Power Systems", Tiva Bussarakons, Defense Electronics, RF Design, June 2006.
3. International Rectifier GH Series DC-DC Converter Data Sheet

End of document