

CASE OUTLINE AND DIMENSION - UB

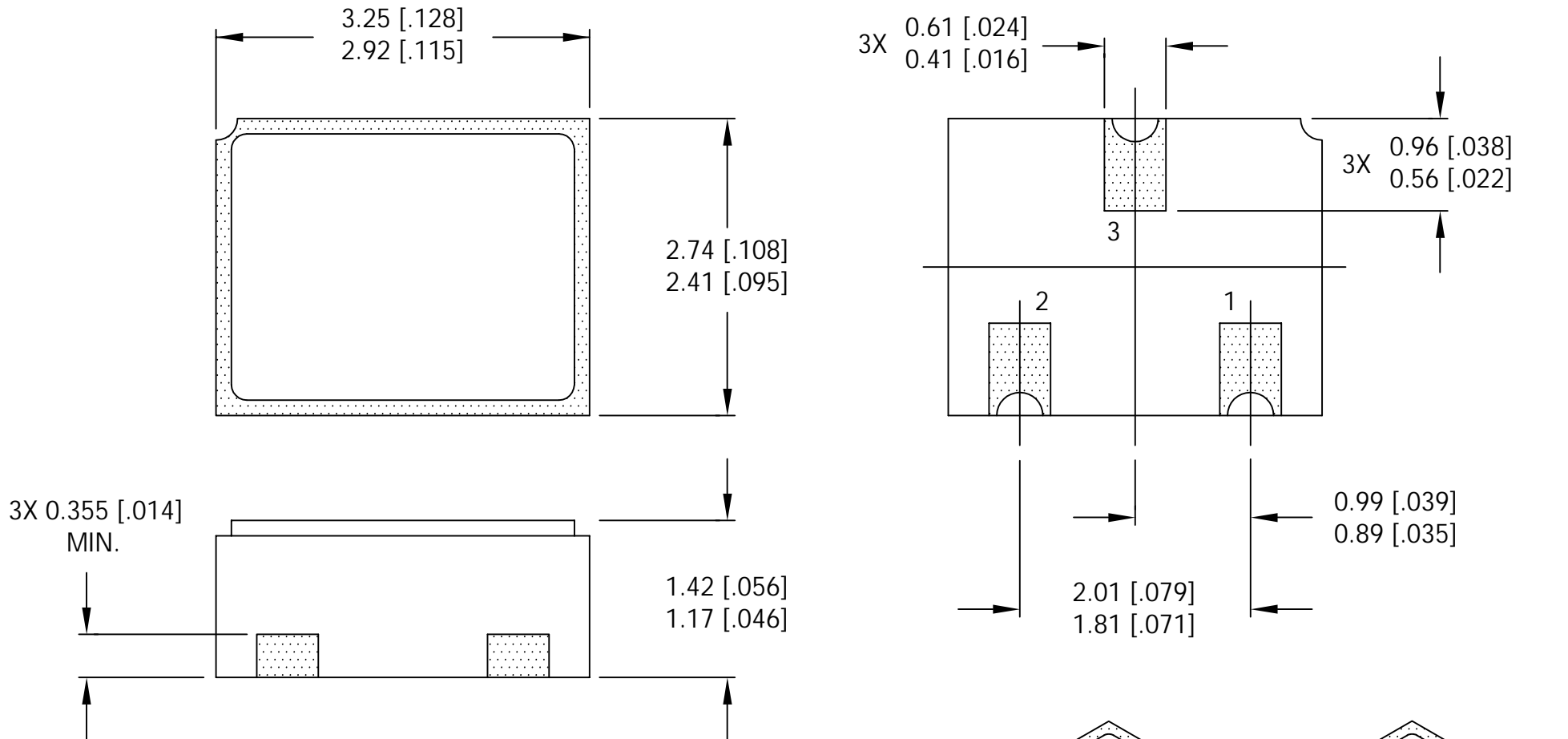

NOTES:

1. DIMENSIONING & TOLERANCING PER ASME Y14.5M-1994
2. CONTROLLING DIMENSION: INCH.
3. DIMENSIONS ARE SHOWN IN MILLIMETERS [INCHES].
4. HATCHED AREAS ON PACKAGE DENOTE METALIZATION AREAS.
5. PAD ASSIGNMENTS: 1 = GATE, 2 = SOURCE, 3 = DRAIN, 4 = SHIELDING CONNECTED TO THE LID.