

ILD8150 in tunable white and multichannel LED applications



About this document

Scope and purpose

Tunable white and multichannel LED lighting are increasingly popular applications and they are becoming more standardized. They enable adjustment of the comparative color temperature (CCT) in the range of 2700 to 6500 K. Color temperature positively affects human activity during the day. In the morning, a cold color temperature is desirable, as this keeps us awake and alert. In the evening, a warm color temperature will help us relax and rest. Some systems are designed to make adjustments automatically according to the time of day. Besides being used in hospitals, schools and offices, tunable white lighting is also widely used in retail outlets, where proper color temperature can make products look more attractive and increase sales. Multiple light sources must be aligned to have the same comparative color temperature with high accuracy to prevent visible color difference.

Furthermore, multichannel LED lighting is also popular in horticultural LED lighting. A combination of four colors – deep blue, hyper-red, far-red and white – are used to achieve more effective energy use. Multichannel RGB lighting is also quite popular in architectural lighting and entertainment applications.

This document describes a multichannel application as a system and includes tips on how to properly design it.

Intended audience

This document is intended for engineers and students designing highly efficient LED drivers with adjustable light temperature or adjustable light color.

Table of contents

Table of contents.....	1
1 System description.....	2
2 Schematics and performance	3
3 Design hints.....	9
4 References for related documents and tunable white/dimming engines.....	11
Revision history.....	12

System description

1 System description

A typical tunable white LED driver block diagram is shown in **Figure 1**. Usually, such systems consist of two or more identical channels of a buck or linear stage connected to the AC-DC source with constant output voltage. Every channel supplies the dedicated LED string with a certain color temperature or color. The ratio between currents in the channels gives the desired result. A control circuit provides analog or pulse-width modulated (PWM) signals to the buck/linear stages. It is usually supplied from the same AC-DC PFC stage through an auxiliary winding supply or from a DC-DC converter deriving the voltage from the main channel.

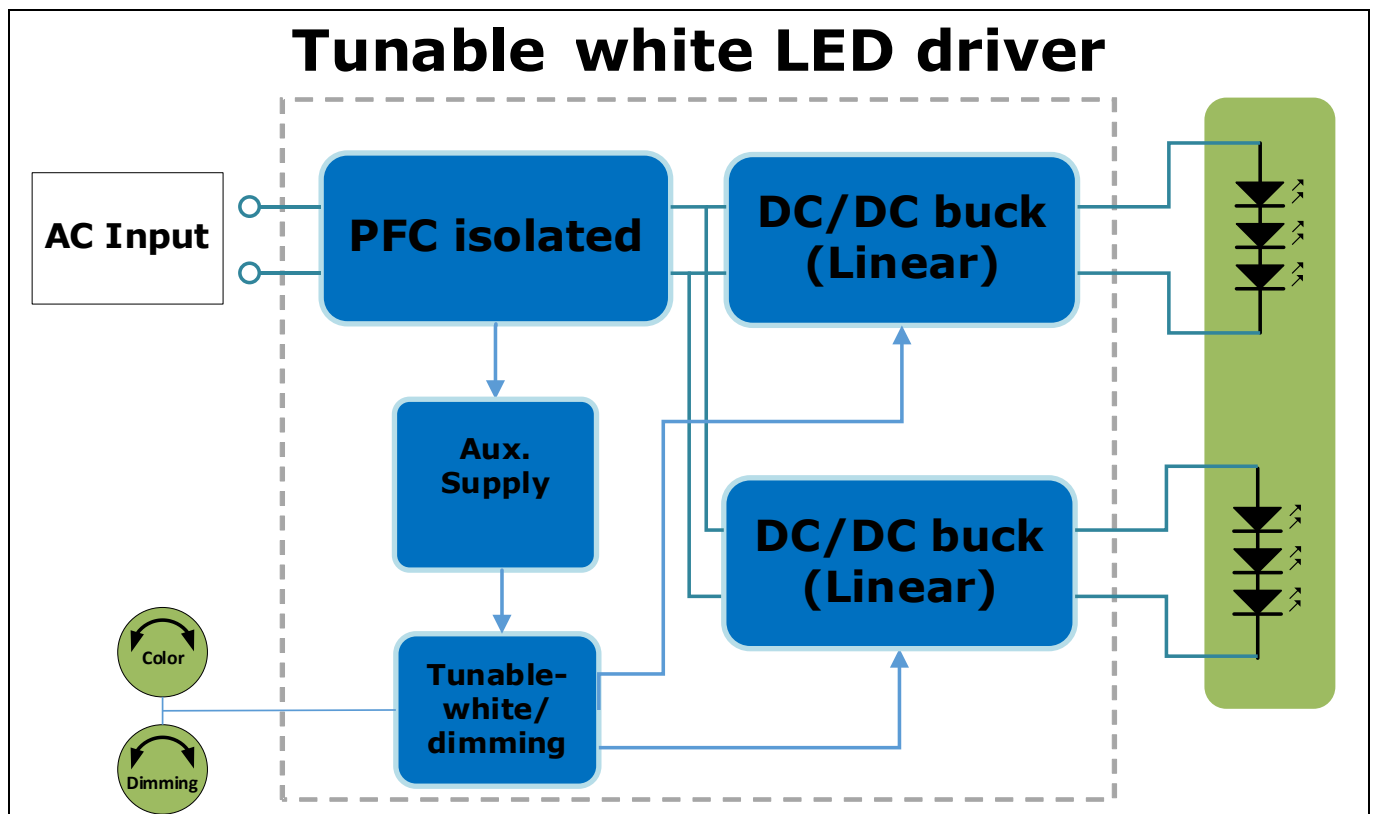

Figure 1 Tunable white block diagram

The tunable white/dimming circuit engine can be wired or wireless. It can be programmed to change the dimming level according to the lighting sensor information, and the light color can be synchronized to the real-time clock to produce more natural light. The system can also be integrated into IoT infrastructure with many sensors, to turn lights on and off and control brightness level and color.

The engine supply and other important subjects are described in section 2. Tunable white and multichannel lighting may appear quite simple, but there are many details that can affect system performance.

ILD8150 in tunable white and multichannel LED applications

Schematics and performance

2 Schematics and performance

Board features:

- Input voltage range: 16 to 70 V DC
- Input auxiliary voltage range: 5 to 15 V DC
- Output LED voltage: 10 to 56 V DC
- Output LED current: 600 to 1050 mA
- Dimming range: 0.5 to 100 percent
- Channels ratio: 0 to 100 percent
- Output auxiliary voltage: 3.3 V DC
- Output auxiliary current: Less than 60 mA
- Standby current consumption of the two channels: Less than 280 μ A
- Board dimensions: 120 mm (L) \times 27 mm (B) \times 20 mm (H)

Table 1 Values

Jumper X9(X29)A	Jumper X9(29)B	Jumper X9(29)C	Output current (mA)
-	V	-	600 (+/-3 percent)
V	V	-	700 (+/-3 percent)
-	-	V	1050 (+/-3 percent)

The tunable white solution based on **ILD8150E**, shown in **Figure 2**, consists of two identical channels and one auxiliary 3.3 V supply. To achieve higher light quality it employs output electrolytic capacitors of 47 μ F to smooth output current. An electrolytic capacitor of 1000 μ F/16 V and an LDO, IFX1117ME V33, are used to provide a smooth supply of 3.3 V and up to 60 mA for the dimming control circuit (e.g. a microcontroller). Two channels operate at frequencies of up to 500 kHz, which minimizes the bus fluctuation effect on current accuracy described earlier. Jumpers X9 and X29 change output current in the range 250 to 1500 mA. The board also includes connector X41, which provides 3.3 V, dimming inputs of the channels, and one common shutdown pin, which puts the buck converters into standby mode.



Figure 2 ILD8150E tunable white evaluation board

ILD8150 in tunable white and multichannel LED applications

Schematics and performance

Figure 3 shows the modular system with a primary stage based on **XDPL8219**, a feedback board and the tunable white board. **XDPL8219** is a digital high-performance secondary-side regulated flyback controller with a high power factor and constant voltage output. By using plug and play Infineon’s **REF-XDPL8219-U40W** (40 W high power factor flyback converter) can simply be combined with the secondary side. This enables a very efficient solution for a tunable white LED driver.

The modular method enables changing the configuration quite easily, so the secondary-stage buck could be exchanged to a linear stage. REF_TW_BCR601_55V_0.5A is such a reference solution, with the linear LED drivers **BCR601** and **BCR602**. This combination with a secondary-side linear regulator enables an efficient as well as cost effective solution for a tunable white LED driver with highest light quality.

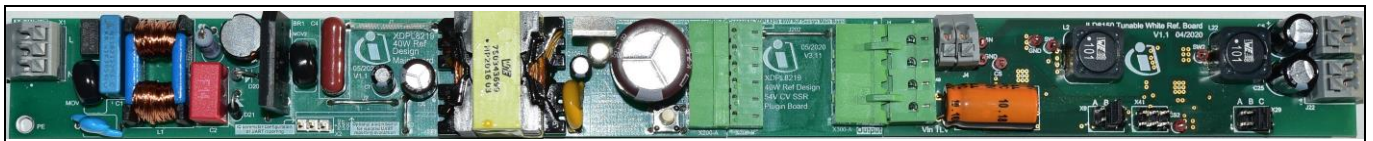

Figure 3 Modular concept – primary stage, constant voltage feedback, ILD8150E tunable white

Figure 4 and **Figure 5** show the board schematics and the layout, respectively.

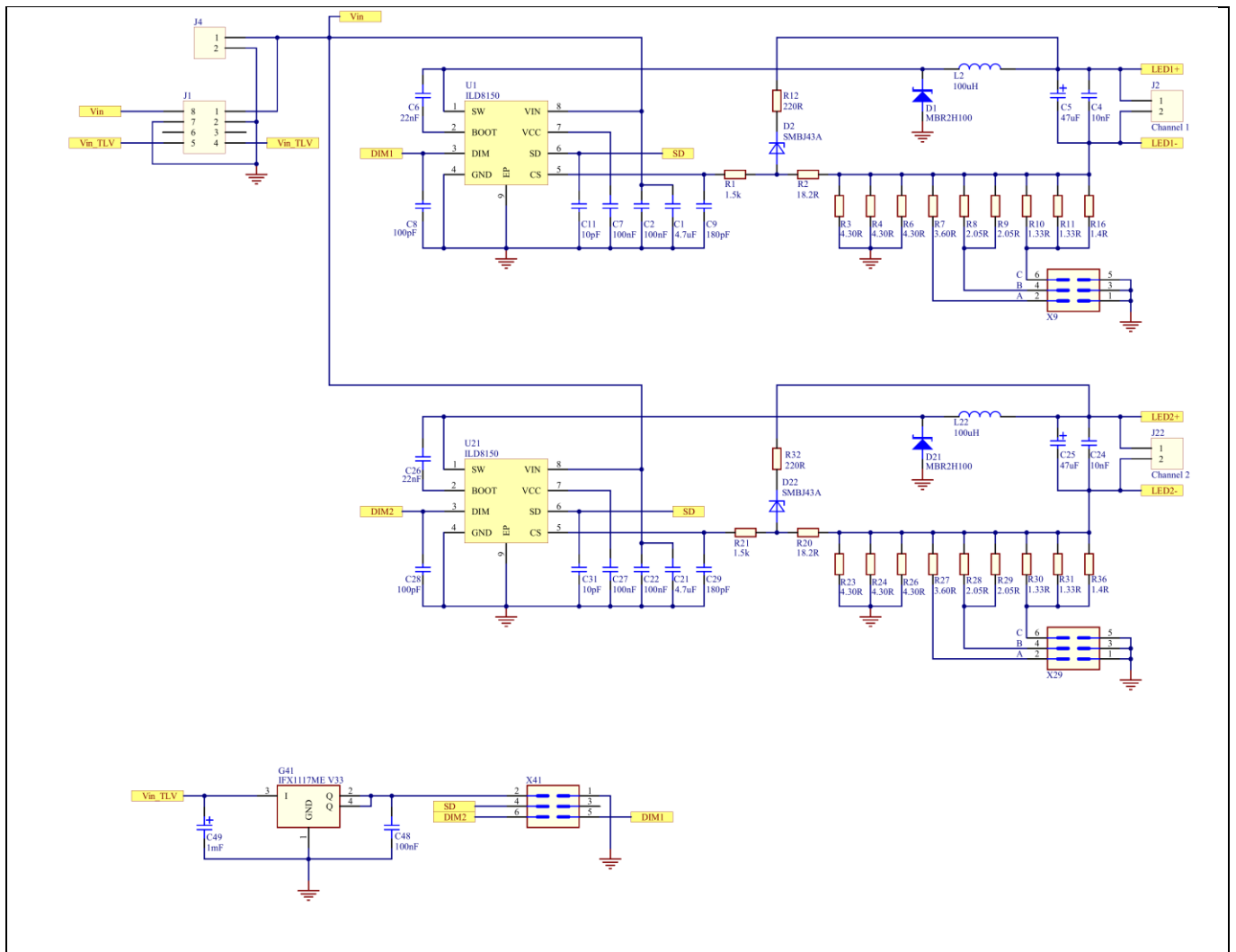

Figure 4 ILD8150E tunable white evaluation board circuit

ILD8150 in tunable white and multichannel LED applications

Schematics and performance

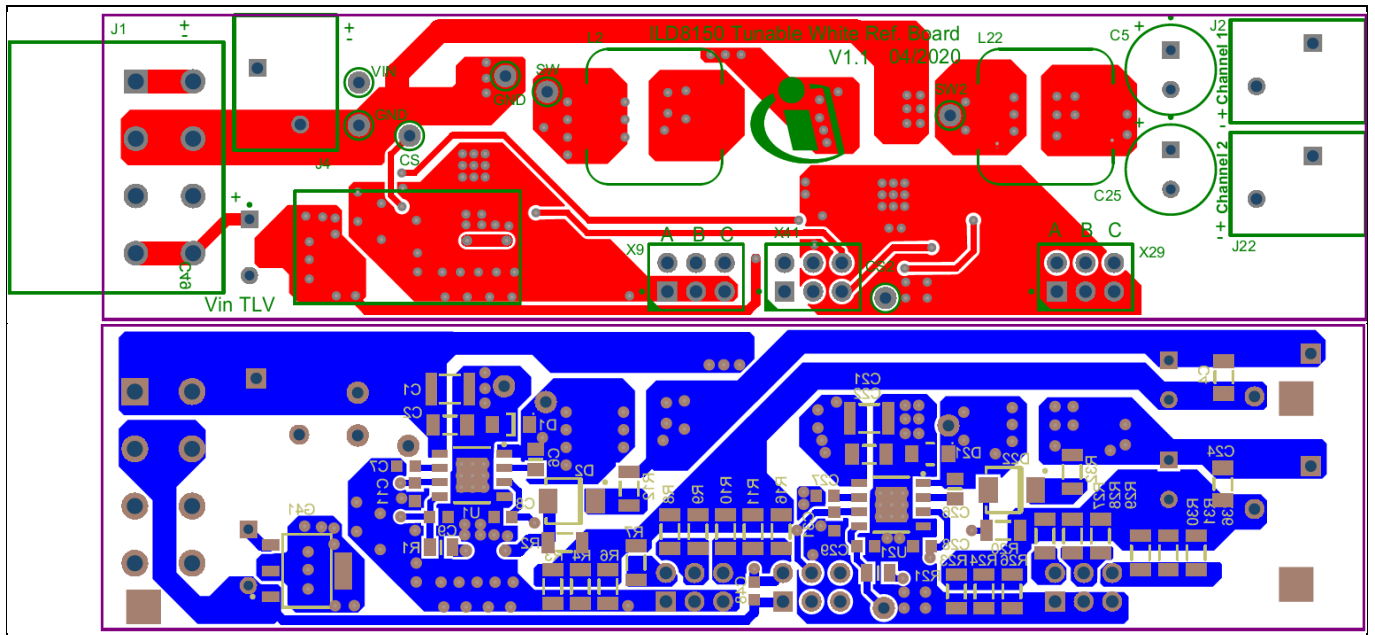

Figure 5 ILD8150E tunable white PCB top and bottom

Attention: Making LED connections across different channels will damage the board!

System efficiency at 230 V AC/50 Hz over the dimming range at equal input power up to 30 W with different LED numbers is shown in **Figure 6**. Jumpers X9 and X29 are used for maximum LED current setting to achieve equal input power.

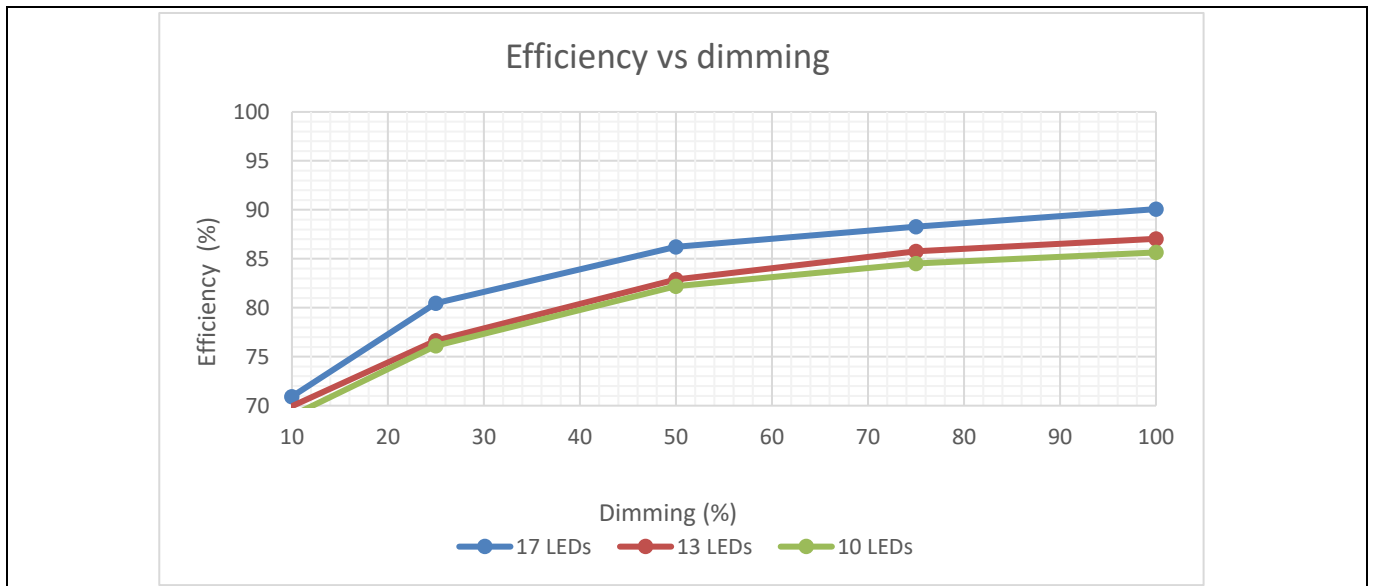

Figure 6 System efficiency over dimming at 50/50 percent channels split with different numbers of LEDs at equal output power. 17 X9 LEDs, X29 jumpers at positions 3 to 4, 13 X9 LEDs, and X29 jumpers at positions 1 to 2 and 3 to 4, 10 X9 LEDs, and X29 jumpers at positions 5 to 6.

ILD8150 in tunable white and multichannel LED applications

Schematics and performance

Power efficiency, THD and power factor are shown in Figures 7 to 9.

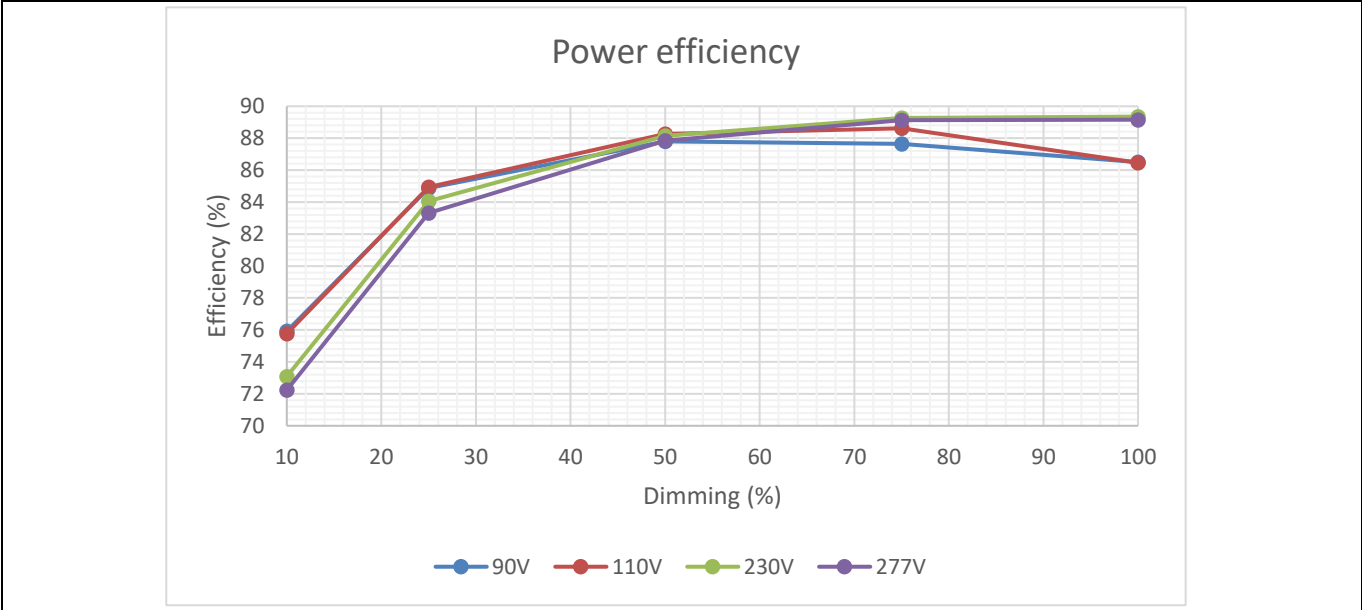

Figure 7 System efficiency over dimming for different input voltages. Maximum output power 43 W.

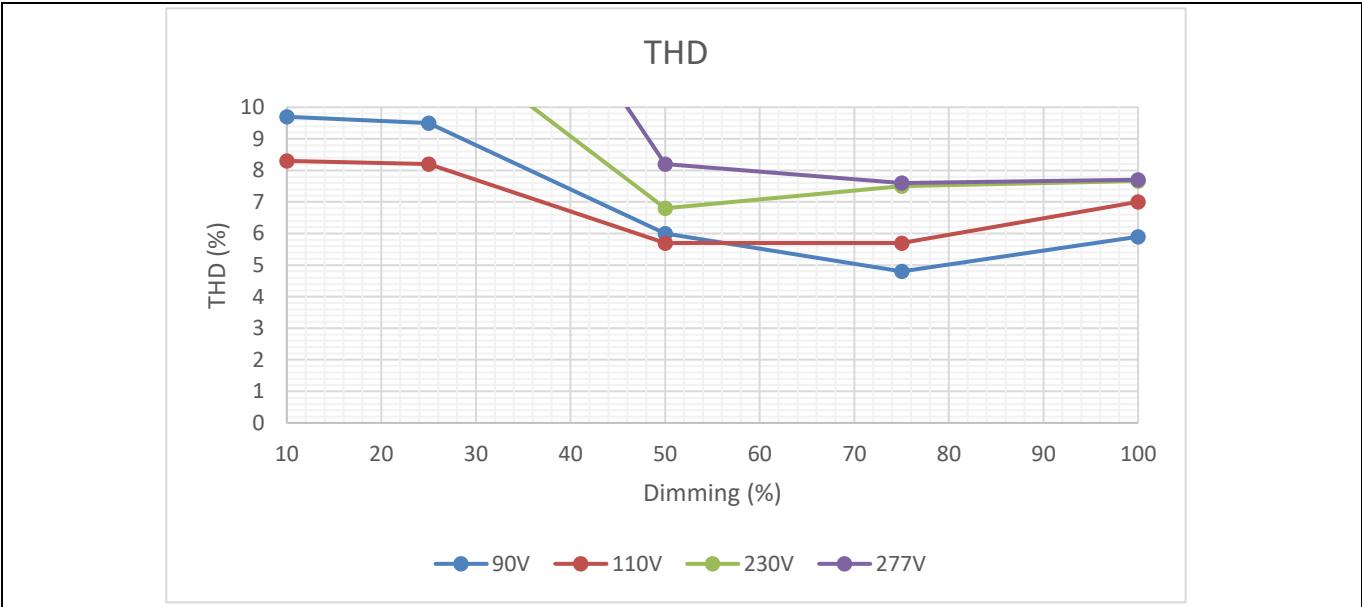

Figure 8 THD over dimming for different input voltages. Maximum output power 43 W.

ILD8150 in tunable white and multichannel LED applications

Schematics and performance

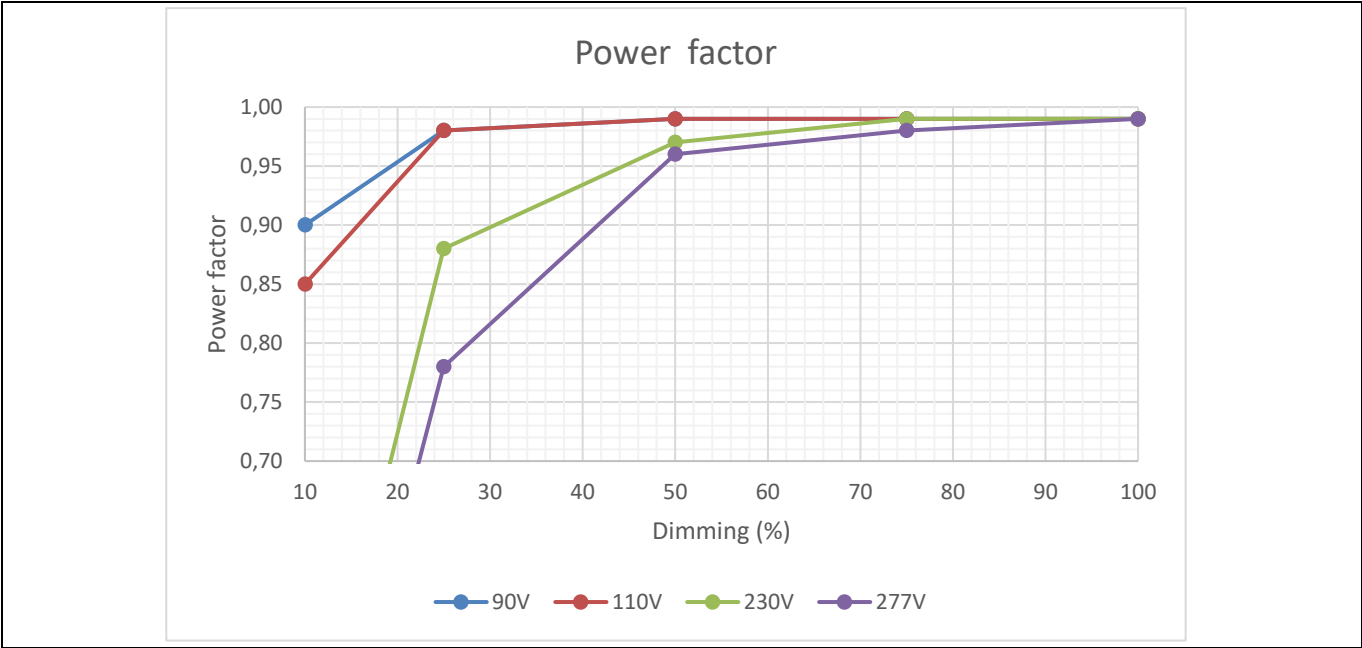

Figure 9 Power factor over dimming for different input voltages. Maximum output power 43 W.

Because the board has one common SD pin, the dimming engine provides an SD signal, which puts it into standby mode. The IC consumption in standby mode is about 100 μ A, so two channels consume about 16 mW.

The bill of materials (BOM) is listed in [Table 2](#), below.

ILD8150 in tunable white and multichannel LED applications

Schematics and performance

Table 2 Bill of materials

#	Quantity	Designator	Description	Manufacturer	Manufacturer part number
1	2	C1, C21	Capacitor 4.7 μ F/100 V/1210/10 percent	TDK	C3225X7S2A475K200AB
2	2	C2, C22	Capacitor 100 nF/100 V/1206/X7R/10 percent	TDK	C3216X7R2A104K160AA
3	2	C4, C24	Capacitor 10 nF/100 V/1206/X7R/10 percent	Murata	GRM319R72A103KA01
4	2	C5, C25	Capacitor 47 μ F/100 V/radial/20 percent	Panasonic	EEU-FS2A470L
5	2	C6, C26	Capacitor 22 nF/100 V/0805/X7R/10 percent	Murata	GRM216R72A223KAC4
6	3	C7, C27, C48	Capacitor 100 nF/50 V/603/X7R/10 percent	AVX	06035C104K4Z2A
7	2	C8, C28	Capacitor 100 pF/50 V/ CAPC1608X90N/C0G/5 percent	KEMET	C0603C0G1H101J030BA
8	2	C9, C29	Capacitor 180 pF/50 V/0603/C0G/ 5 percent	Murata	GRM1885C1H181JA01
9	2	C11, C31	Capacitor 10 pF/50 V/0603/C0G/5 percent	Murata	GCM1885C1H100JA16
10	1	C49	Capacitor 1 mF/16V/THT/20 percent	TDK Corporation	B41888C4108M000
11	7	CS, CS2, GND, SW, SW2, VIN, X5	5000/CON-THT-TP-5000	Keystone	5000
12	2	D1, D21	Diode 2 A/100 V/SOD-123F	ON Semiconductor	MBR2H100SFT3G
13	2	D2, D22	Diode SMBJ43A/DO-214AA	ON Semiconductor	SMBJ43A
14	1	G41	Power IFX1117ME V33/PG-SOT223	Infineon Technologies	IFX1117ME V33
15	1	J1	691309510004	Würth Elektronik	691309510004
16	3	J2, J4, J22	691412320002	Würth Elektronik	691412320002
17	1	J3-J	Jumper black	Samtec	SNT-100-BK-T
18	2	L2, L22	Inductor 100 μ H/1210	Würth Elektronik	7447709101
19	2	R1, R21	Resistor 1.5 k/150 V/0805/1 percent	Vishay	CRCW08051K50FK
20	2	R2, R20	Resistor 18.2 R/200 V/1206/1 percent	Vishay	CRCW120618R2FK
21	6	R3, R4, R6, R23, R24, R26	Resistor 4.30 R/1206/1 percent	Vishay	CRCW12064R30FK
22	2	R7, R27	Resistor 3.60 R/1206/1 percent	Vishay	CRCW12063R60FK
23	4	R8, R9, R28, R29	Resistor 2.05 R/1206/1 percent	Vishay	CRCW12062R05FK
24	4	R10, R11, R30, R31	Resistor 1.33 R/1206/1 percent	Vishay	CRCW12061R33FK
25	2	R12, R32	Resistor 220 R/1206/1 percent	Vishay	CRCW1206220RFK
26	2	R16, R36	Resistor 1.4 R/200 V/1206/1 percent	Vishay	CRCW12061R40FK
27	2	U1, U21	ILD8150/SOIC127P600X170-9N-V2	Infineon Technologies	ILD8150
28	3	X9, X29, X41	TSW-103-08-G-D/ HDRV6W64P254_3X2_508X762X838B	Samtec	TSW-103-08-G-D
29	1	X9-J	Jumper black 3x	Samtec	SNT-100-BK-T

Design hints

3 Design hints

Pulse width modulation (PWM) dimming of two or more channels can create interference, because the PWM frequencies and phases are not exactly the same. If these interferences are in the range of a few Hz to a few hundred Hz, they may cause visible flicker and stroboscopic effects. **Figure 10** is an example of two channels operating in PWM dimming mode at 3.4 kHz. The pink channel is a light sensor signal; the blue is the sum of the currents of the two LED channels. An interference frequency of 43 Hz is clearly visible in both signals.

On the evaluation board, 47 μ F electrolytic capacitors are used at the LED output of each channel to filter the PWM dimming frequency of 3.4 kHz.

A better solution could be to synchronize the PWM frequencies in multichannel applications to avoid flicker. If multiple light sources with tunable white are used, this is quite difficult, so in this case, purely analog dimming is preferable.

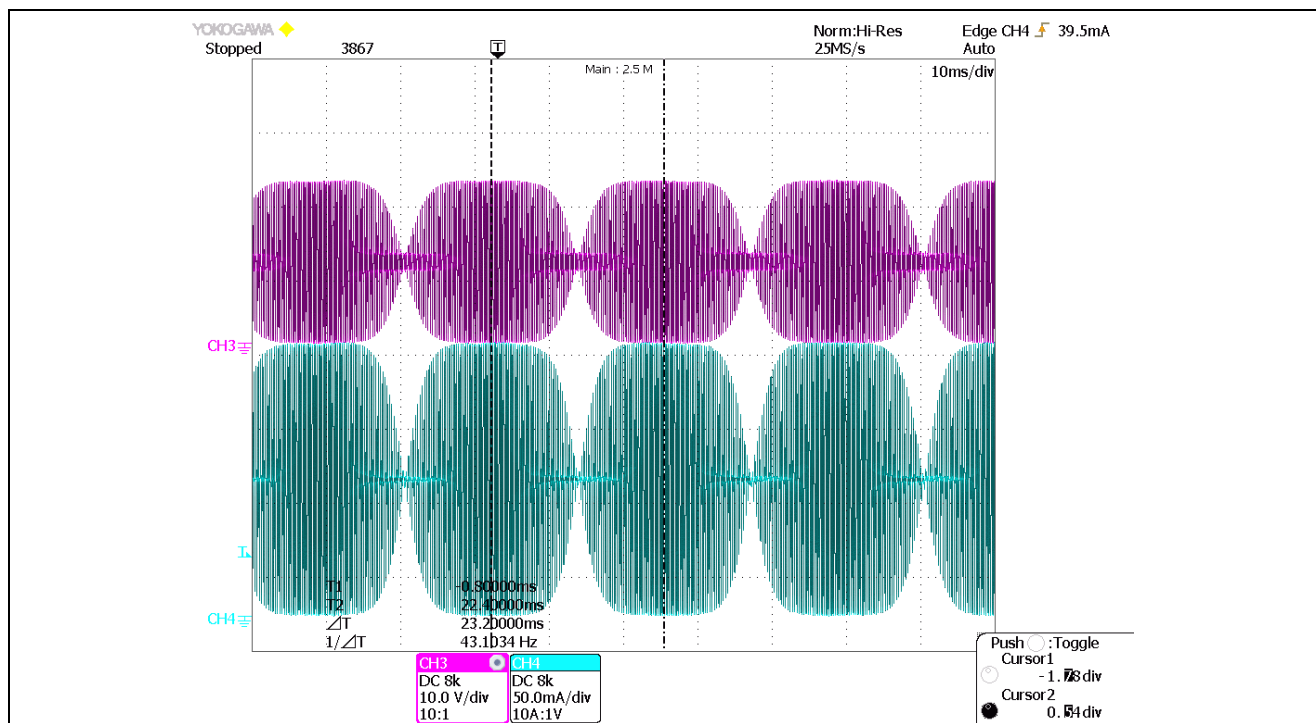

Figure 10 Interference effect at hybrid dimming mode when two channels are not synchronized

Bus voltage fluctuation during burst mode can affect light quality by causing flicker at low dimming levels in PWM modes. This happens when the switching period and dimming pulse width are similar. In **Figure 11**, you can see two oscillograms; green is the bus voltage, pink is the output current. On the left, the switching period is similar to a dimming pulse of 1 percent, and as a result, the LED buck converter cannot regulate LED current in one cycle, which results in flicker at the burst mode frequency. On the right, the switching period is ten times shorter than the minimum dimming pulse; therefore, the LED current is much more precise, and the flicker level is negligible.

If you consider PWM dimming using its calculated minimum frequency switching, select a much higher switching period than the minimum dimming pulse. This will help to avoid or minimize the flicker level at minimum dimming in burst mode.

ILD8150 in tunable white and multichannel LED applications

Design hints

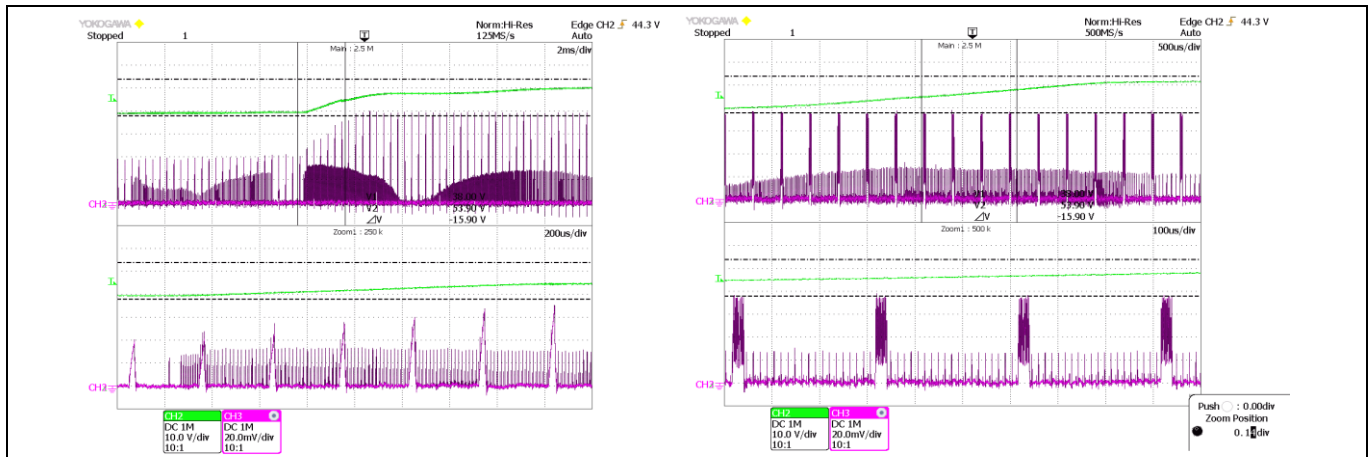

Figure 11 Hybrid dimming mode at bus voltage fluctuation. On the left – low switching frequency, right – high switching frequency.

Comparative color temperature accuracy is important. Mismatching minimum currents may lead to different light colors, different from dimming accuracy. If the second-stage channels are supplied from the same bus voltage, having the same LED number and operating temperature, the mismatch will be minimized. Color temperature accuracy, in this case, is related to dimming accuracy as an error between a linear dimming curve and a straight line, as shown in **Figure 12**.

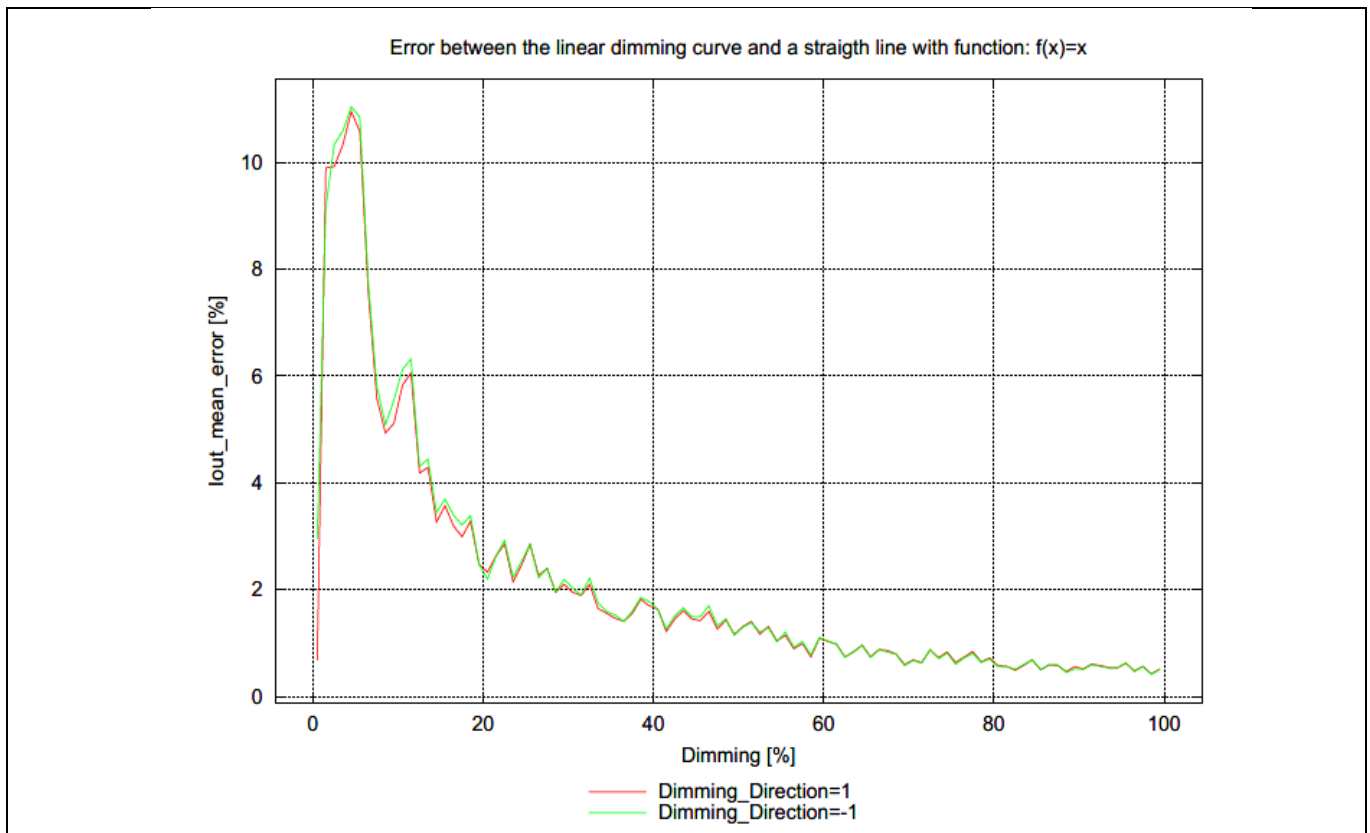

Figure 12 Comparative color temperature accuracy over dimming for tunable white application

It is much easier to achieve high color accuracy when bus voltage and LED voltages are similar, considering only IC accuracy and component tolerances.

4 References for related documents and tunable white/dimming engines

- [1] Infineon: “Application Note AN_1809_PL39_1810_124440 (Revision 1.1)”, 2019-01-23
(https://www.infineon.com/dgdl/Infineon-ApplicationNote_reference_design_REF_ILD8150_DC_1.5A_LightingICs_LED_driver-ApplicationNotes-v01_00-EN.pdf?fileId=5546d462689a790c0168c39bfd86810)
- [2] Infineon: “Application Note AN_1907_PL39_1907_083934 (Revision 1.0)”, 2019-08-05
(https://www.infineon.com/dgdl/Infineon-Reference_design_REF_ILD8150_DC_1.5A_high_frequency_operation-ApplicationNotes-v01_00-EN.pdf?fileId=5546d4626d66c2b1016d73f768f820ae)

Revision history

Revision history

Document version	Date of release	Description of changes
V 1.0	29-01-2021	First release

Trademarks

All referenced product or service names and trademarks are the property of their respective owners.

Edition 2021-01-29

Published by

Infineon Technologies AG

81726 Munich, Germany

© 2021 Infineon Technologies AG.

All Rights Reserved.

Do you have a question about this document?

Email: erratum@infineon.com

Document reference

AN_2004_PL39_2006_121319

IMPORTANT NOTICE

The information contained in this application note is given as a hint for the implementation of the product only and shall in no event be regarded as a description or warranty of a certain functionality, condition or quality of the product. Before implementation of the product, the recipient of this application note must verify any function and other technical information given herein in the real application. Infineon Technologies hereby disclaims any and all warranties and liabilities of any kind (including without limitation warranties of non-infringement of intellectual property rights of any third party) with respect to any and all information given in this application note.

The data contained in this document is exclusively intended for technically trained staff. It is the responsibility of customer's technical departments to evaluate the suitability of the product for the intended application and the completeness of the product information given in this document with respect to such application.

For further information on the product, technology, delivery terms and conditions and prices please contact your nearest Infineon Technologies office (www.infineon.com).

WARNINGS

Due to technical requirements products may contain dangerous substances. For information on the types in question please contact your nearest Infineon Technologies office.

Except as otherwise explicitly approved by Infineon Technologies in a written document signed by authorized representatives of Infineon Technologies, Infineon Technologies' products may not be used in any applications where a failure of the product or any consequences of the use thereof can reasonably be expected to result in personal injury.