

PSI5-S

Peripheral Sensor Interface with Serial PHY

AURIX™ TC2xx Microcontroller Training
V1.0



[Please read the Important Notice and Warnings at the end of this document](#)

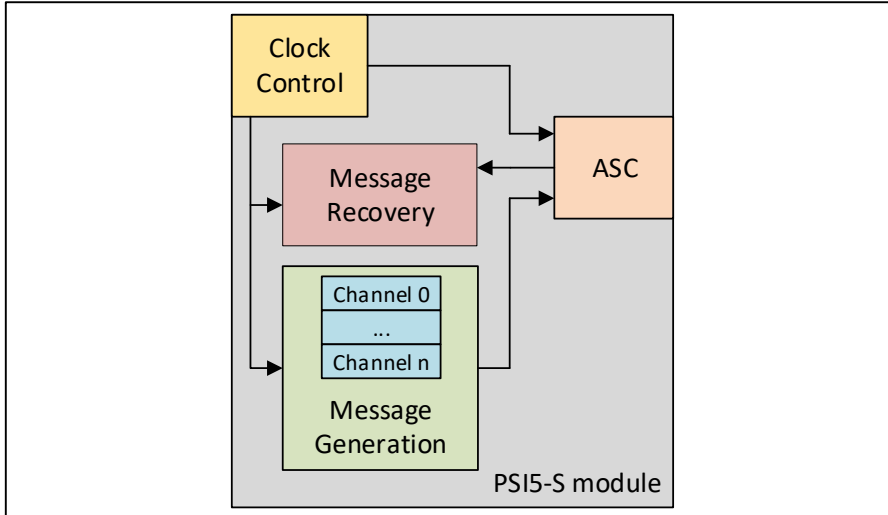

Highlights

The Peripheral Sensor Interface is an interface for automotive sensor applications.

PSI5-S module supports PSI5 protocol specification V2.0 Powertrain substandard.

Data rates of 125 kbit/s and 189 kbit/s are supported.

Key Features

8 PSI5-S channels sharing one common ASC module

Message recovery and generation blocks

Error detection and handling

Customer Benefits

Simplifies and reduces cost of integration due to reduced number of required pins

Simplifies implementation while the message recovery is done in HW

Reduces software overhead while the errors will be detected by the module itself

8 PSI5-S channels sharing one common ASC module

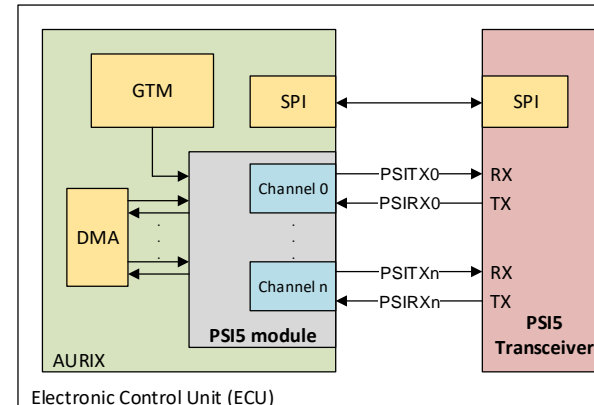
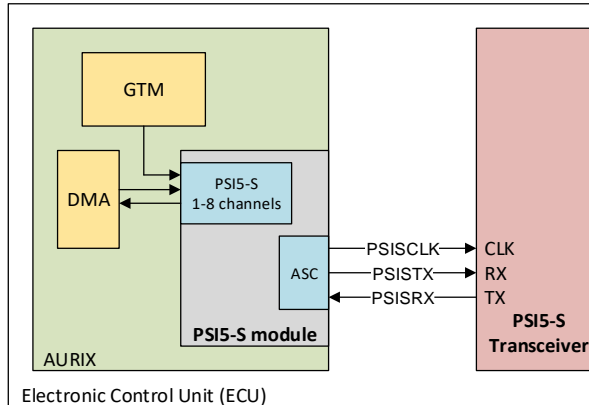

- › Each channel supports 6 sensor slots (allows greater bus topology flexibility)
- › In comparison with PSI5 module, reduction of required pins:
 - 2 pins (TX/RX) + 1 CLK pin for up to all 1-8 channels (**PSI5-S** module)
 - 2 pins (TX/RX) per channel and optionally 4 SPI pins (PHY configuration) (**PSI5** module)
- › One common ASC module consists of 3 pins (PSISTX, PSISR, and PSISCLK)
- › PSISTX and PSI5RX pins act as a transmit data output and receive data input signals respectively.
- › PSISCLK pin provides the clock to drive the external PHY

Message recovery and generation blocks

› Message recovery block

- ASC format 10 Bit: 1 Start Bit, 8 Data bits, 1 Stop Bit (Up Stream)
- Each PSI5 Frame is transported in a Packet Frame consisting of 3 to 6 UART Frames transmitted back to back, i.e. with exactly one stop bit - no additional delay
- Configurable data length 8 .. 28 bit + 3 bit PSI5 CRC or 1 bit PSI5 Parity
- Packet Frames are separated by a programmable idle time (1 .. 16 idle bits)
- Two independent time bases for Time Stamp: clocked by GTM (1 out of n GTM signals is selectable) or internal periodic trigger generator (24-Bit time stamp with resolution of 1µs)
- CRC check of received PSI5 sensor data, CRC code still transparent

› Message generation block

- ASC format 11 Bit: 1 Start Bit, 8 Data bits, 1 Parity, 1 Stop Bit (Down Stream)
- Downstream data transmission by 2 different ASC commands (support for both “Tooth Gap” or “Pulse Width” bit coding methods)
- Start sequence generator for downstream data (can be switched off)
- Bit stuffing generator for downstream data (can be switched off)
- CRC generator (3 or 6 bit CRC) for downstream data (can be switched off)

Error detection and handling

- › Each PSI5-S channel can detect and signal the following error conditions:
- › Protocol Level:
 - Packet Frame CRC Error (XCRC)
 - PSI5 Frame Checksum error (CRCI)
 - Frame not sent in time / UART Frames missing (TEI)
 - Error Bits Set in Packet Frame (HDI)
 - Errors signaled by ASC Sub Module
 - parity error (PE)
 - framing error (FE)
 - overrun error (OE)
- › Transfer Management Level:
 - Receive Data Buffer Overrun (RBI)
 - ECU to Sensor Data Buffer Underrun (TBI)

PSI5-S

System integration

PSI5-S module is connected to several external modules:

- › As an input clock source for the Clock Control module, f_{SPB} or $f_{SPBMAX2}$ can be selected
- › Interrupt Router: Schedules service requests coming from 8 interrupt sources available for the PSI5-S module
- › Port Control: Connects the PSISTX, PSISR, and PSISCLK pins to the external GPIO pins
- › GTM: 8 outputs of the GTM module are connected to the timer inputs to support timestamp generation

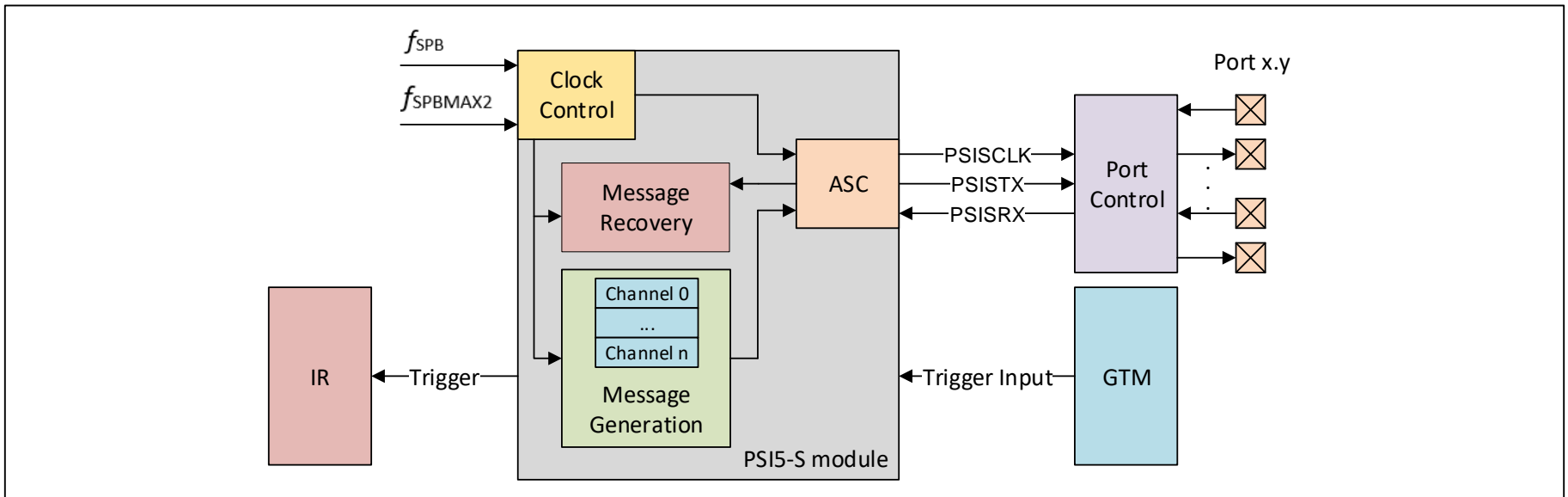

Application example

Connection of sensors to an ECU

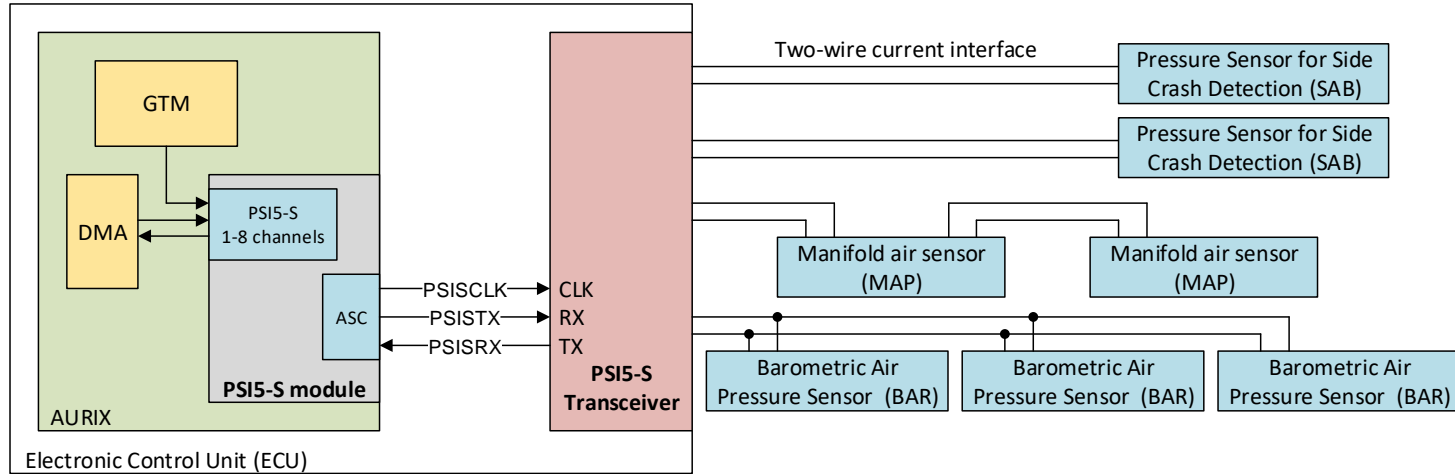

Overview

- > This application example shows typical usage of PSI5-S module in airbag or powertrain domain
- > PSI5-S module is connect to the external PSI5-S transceiver module (PHY) whose role is to fulfil physical layer requirement that cannot be achieved with MCU alone

Advantages

- > The sensors are connected to the ECU by just two wires, using same lines for power supply and data transmission
- > This allows high reliability data transfer at lowest possible implementation overhead and cost

Trademarks

All referenced product or service names and trademarks are the property of their respective owners.

Edition 2019-06

Published by

**Infineon Technologies AG
81726 Munich, Germany**

**© 2019 Infineon Technologies AG.
All Rights Reserved.**

Do you have a question about this document?

Email: erratum@infineon.com

Document reference

**AURIX_Training_1_
Peripheral_Sensor_Interface_with_
Serial_PHY**

IMPORTANT NOTICE

The information given in this document shall in no event be regarded as a guarantee of conditions or characteristics (“Beschaffenheitsgarantie”).

With respect to any examples, hints or any typical values stated herein and/or any information regarding the application of the product, Infineon Technologies hereby disclaims any and all warranties and liabilities of any kind, including without limitation warranties of non-infringement of intellectual property rights of any third party.

In addition, any information given in this document is subject to customer’s compliance with its obligations stated in this document and any applicable legal requirements, norms and standards concerning customer’s products and any use of the product of Infineon Technologies in customer’s applications.

The data contained in this document is exclusively intended for technically trained staff. It is the responsibility of customer’s technical departments to evaluate the suitability of the product for the intended application and the completeness of the product information given in this document with respect to such application.

For further information on the product, technology, delivery terms and conditions and prices please contact your nearest Infineon Technologies office (www.infineon.com).

WARNINGS

Due to technical requirements products may contain dangerous substances. For information on the types in question please contact your nearest Infineon Technologies office.

Except as otherwise explicitly approved by Infineon Technologies in a written document signed by authorized representatives of Infineon Technologies, Infineon Technologies’ products may not be used in any applications where a failure of the product or any consequences of the use thereof can reasonably be expected to result in personal injury.